

**Kid**  **Youth**



本型錄圖片僅供參考 請以實際產品為主  
Image only for reference, please make the object as final standard.

**M** 系列使用手冊  
Operation manual

Ver 202105







# M2+/M6+ 系列組裝說明



**注意**

- 適用年齡4歲以上。
- 請由成人組裝並注意孩童安全。
- 孩童使用時務必由成人陪同。

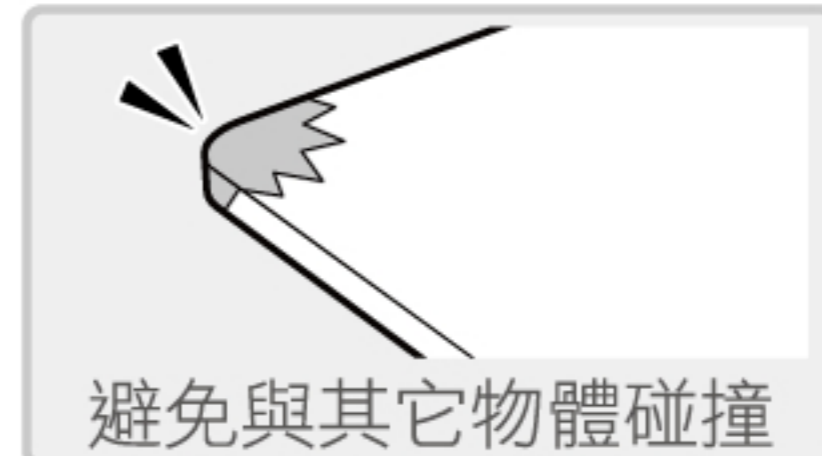

**1** 桌板 M2+ | XXS

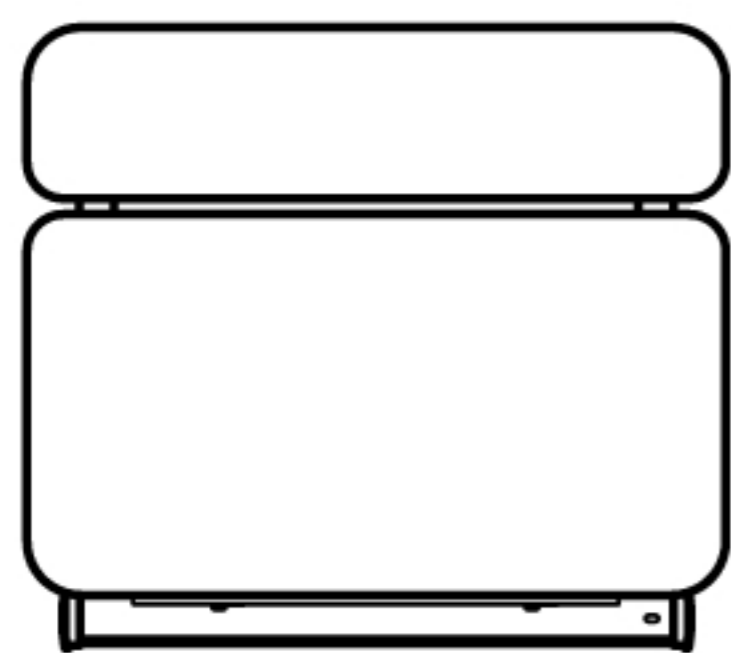

M6+ | XS  
S

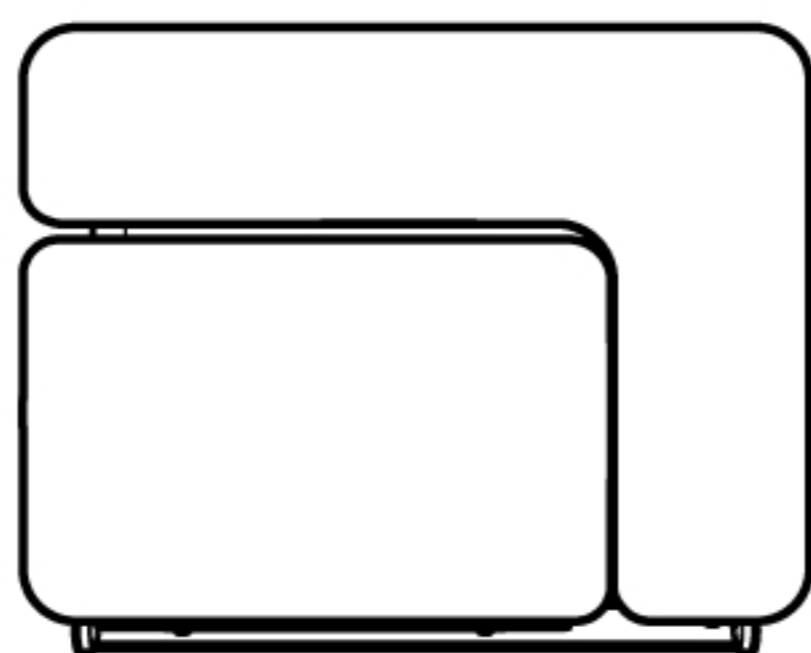

## 五金包

M 螺絲 X 4

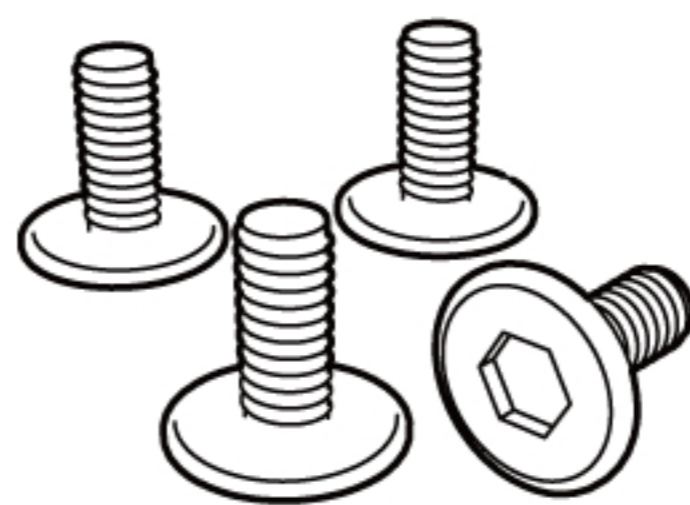

M6\*12mm

N 桌腳螺絲 X 4

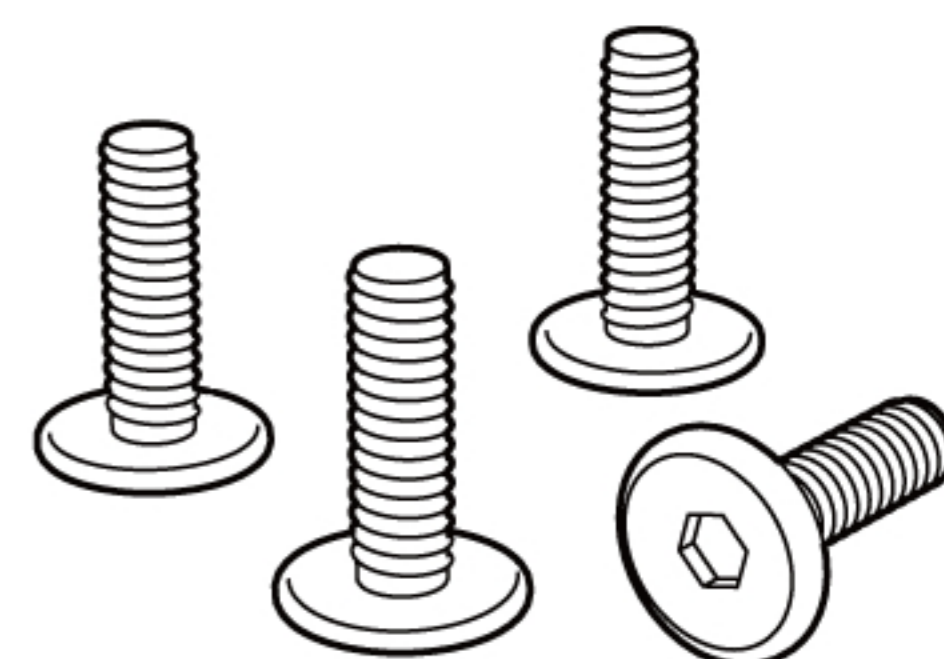

M6\*19mm

F 螺絲蓋子 X 4

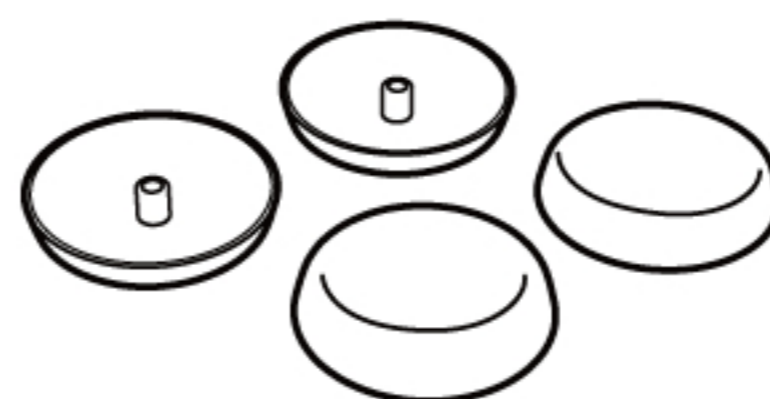

六角板手



NO.4

**2** 桌腳

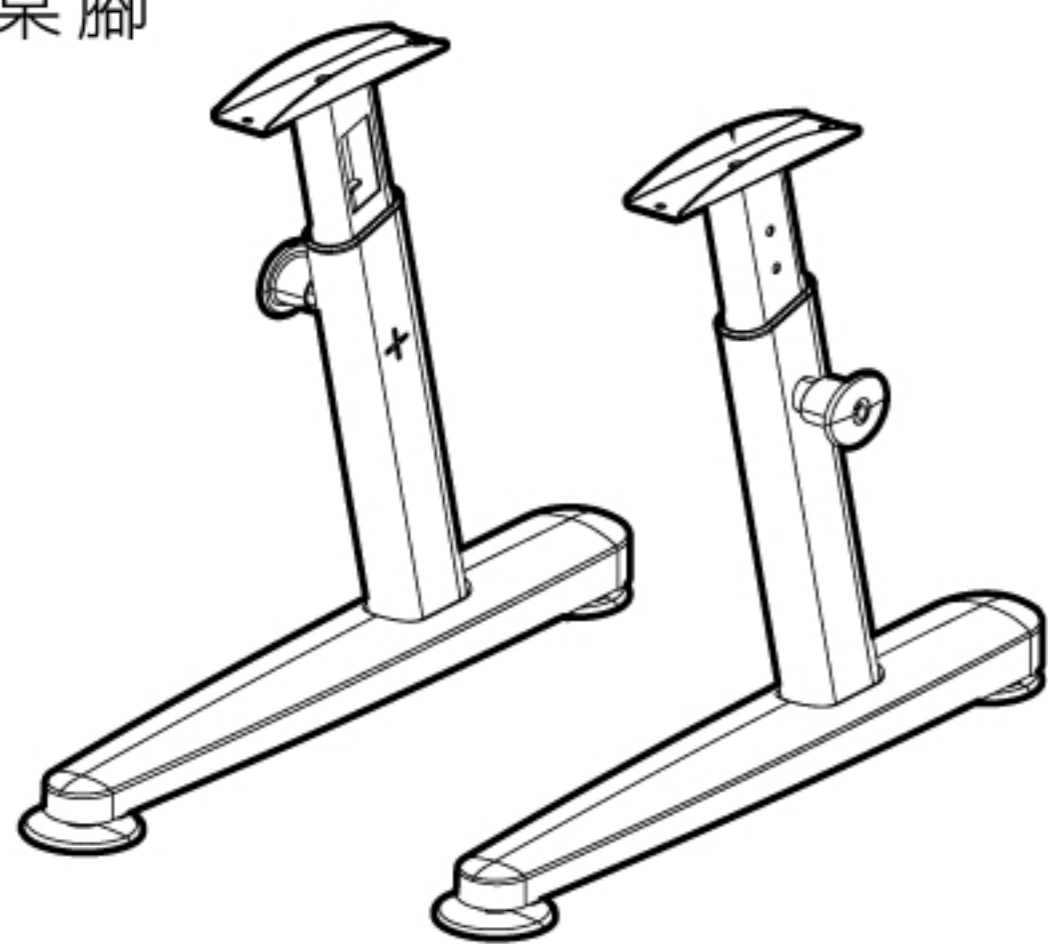

**3** 中橫桿

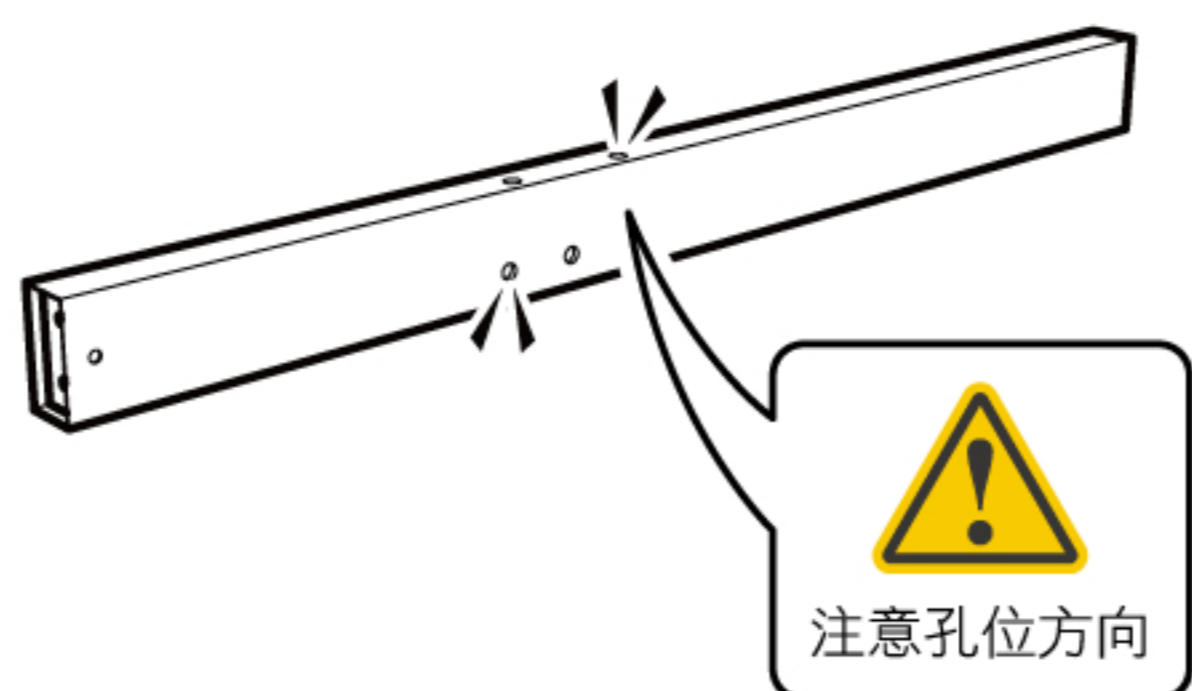

**4** 掀板五金

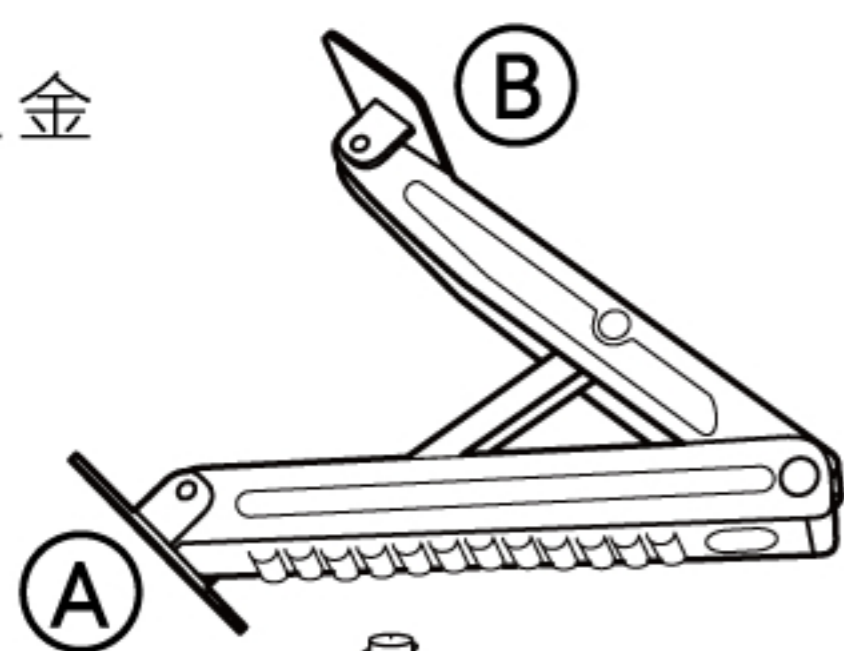

**4** -H 螺絲  
4.8\*14mm

**4** -E 螺絲  
M4\*12mm

**5** 緩衝棒

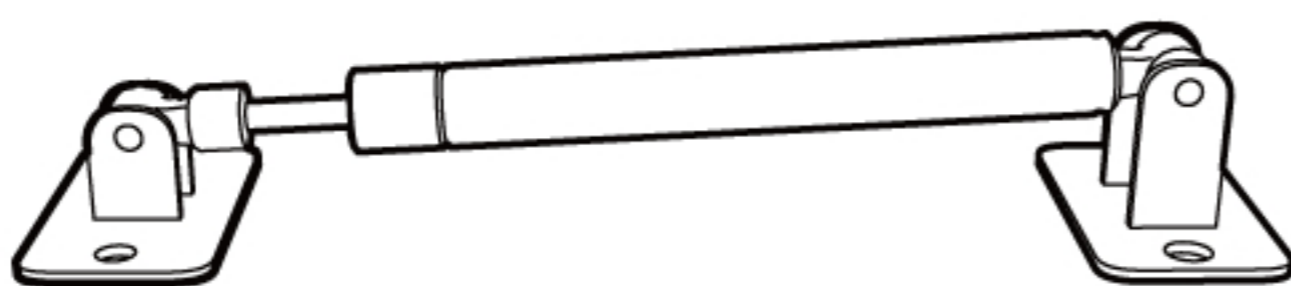

**5** -H 螺絲  
4.8\*14mm

**5** -E 螺絲  
M4\*12mm

**1**

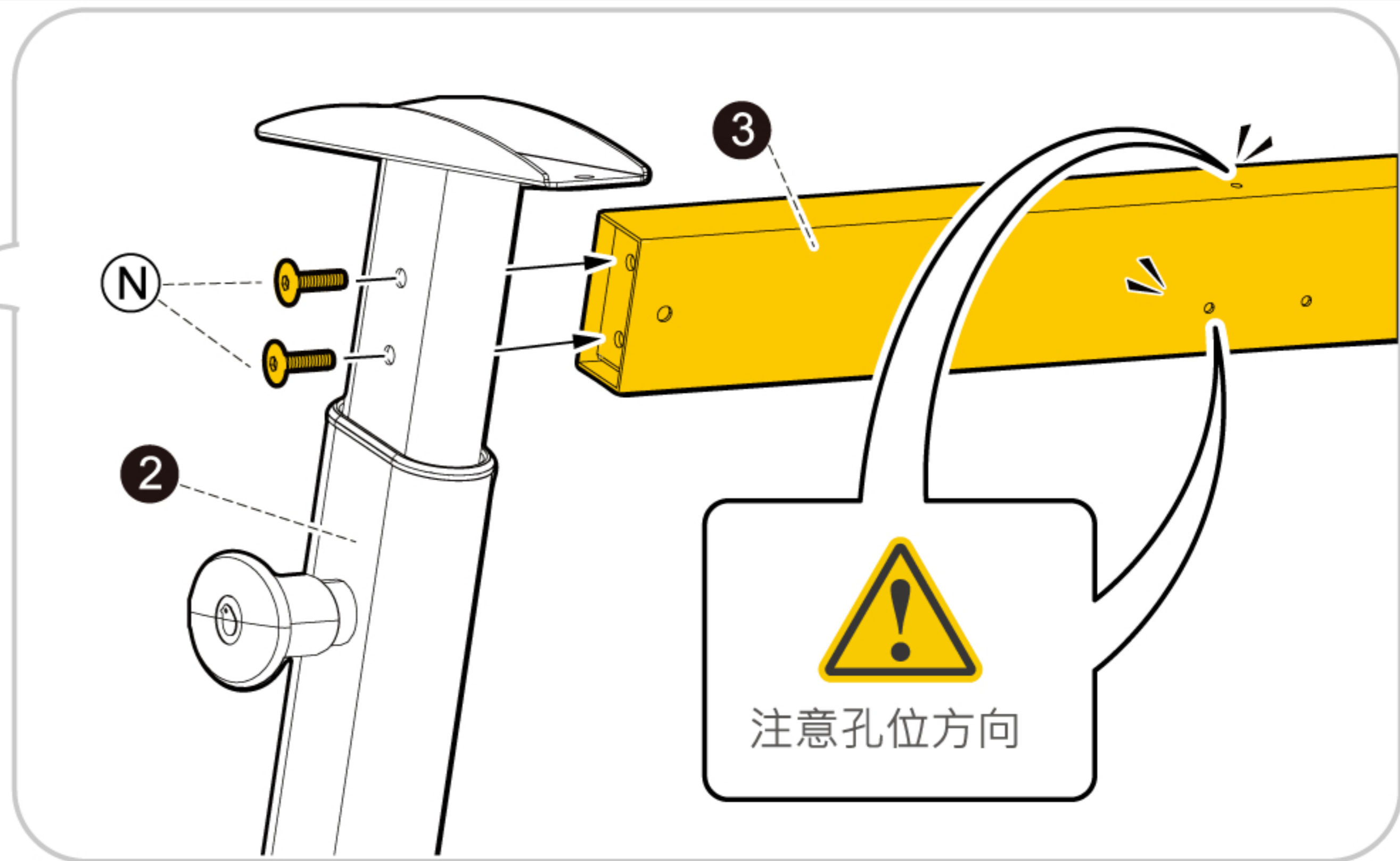
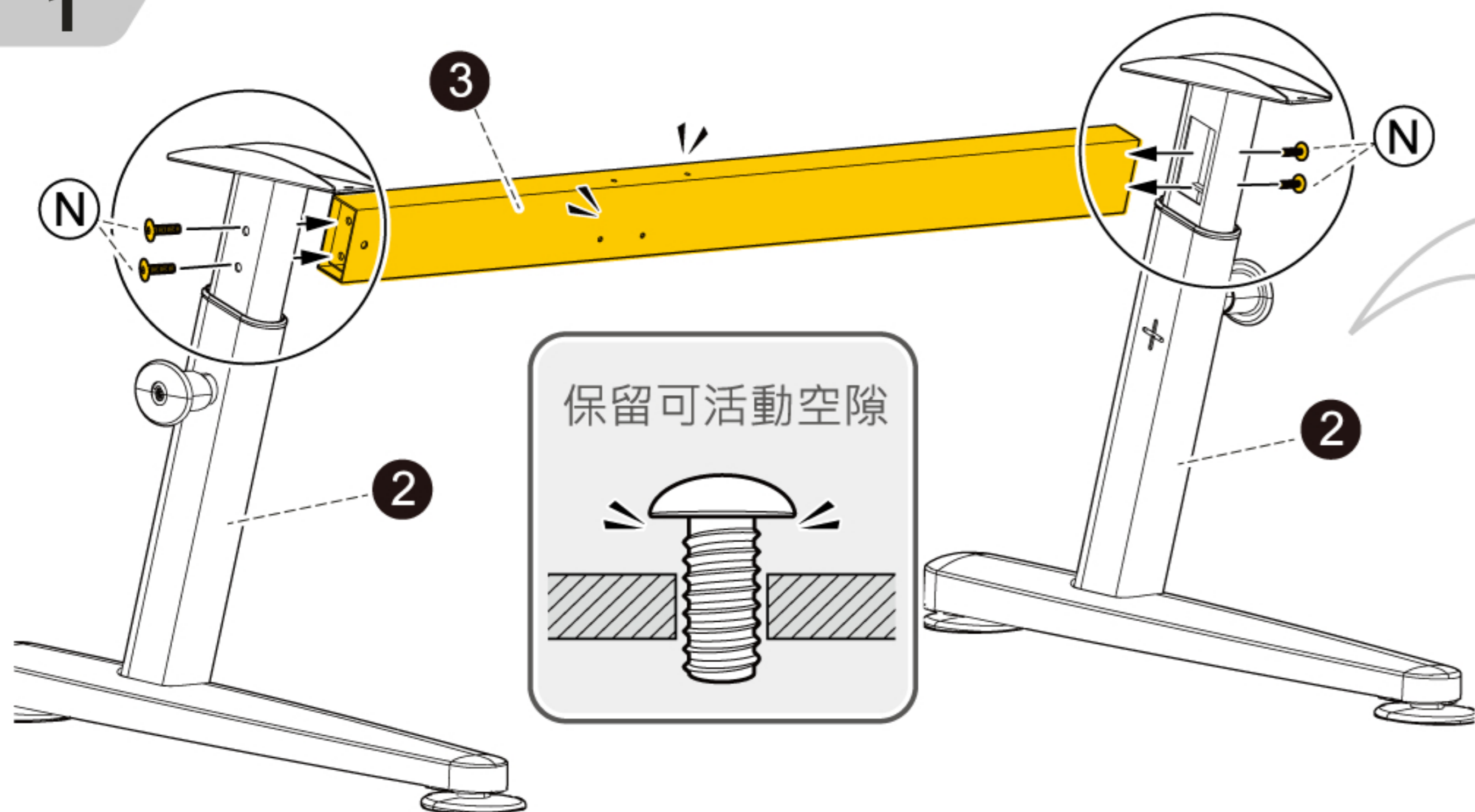

**2**

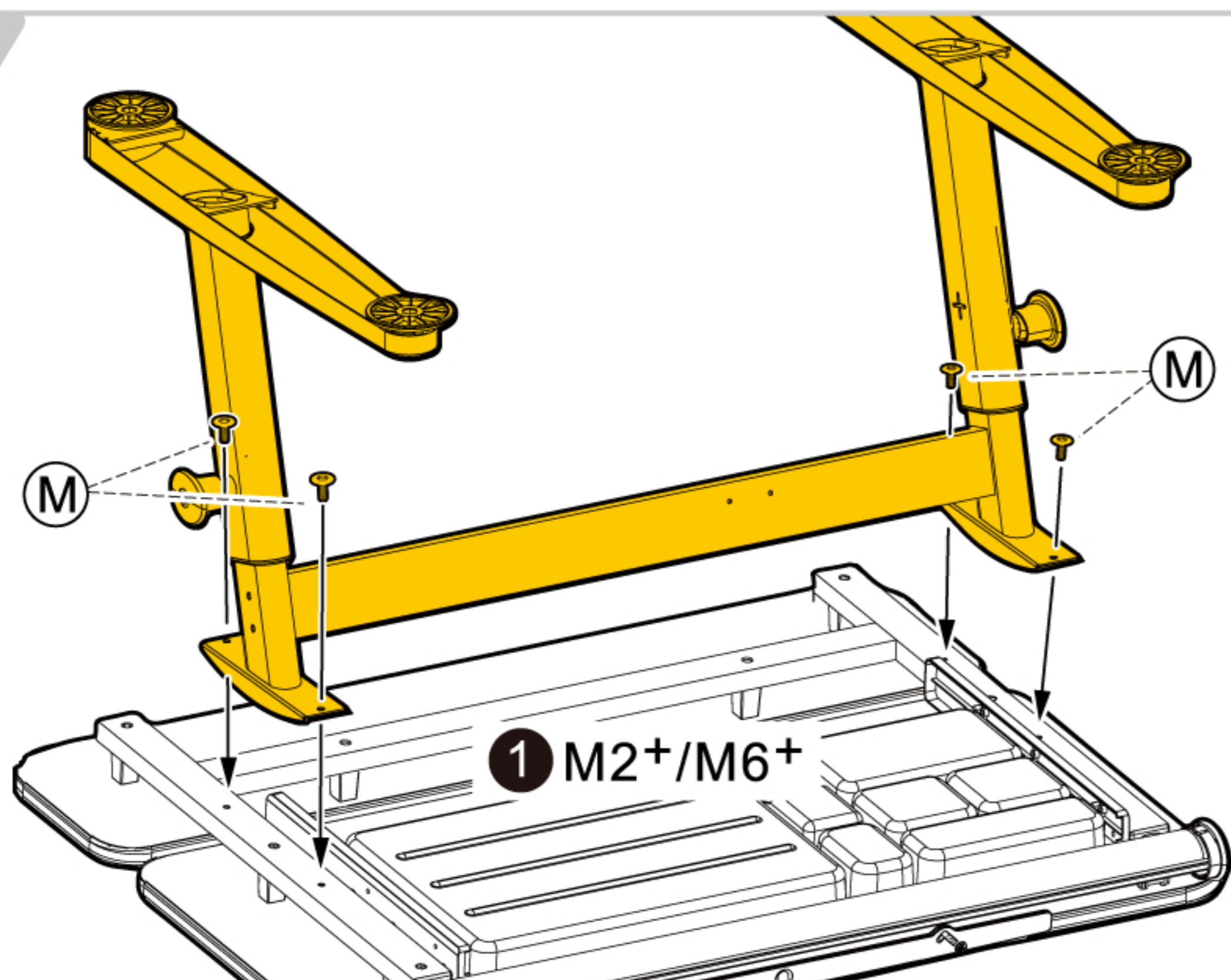

## 特別說明

1. 執行步驟 2 ⇒ 檢查桌腳是否對稱。
2. 確認步驟 1 ⇒ 桌腳 2 與中橫桿 3 是否呈 90°。
3. 再將步驟 1 ⇒ 螺絲 N 鎖緊。

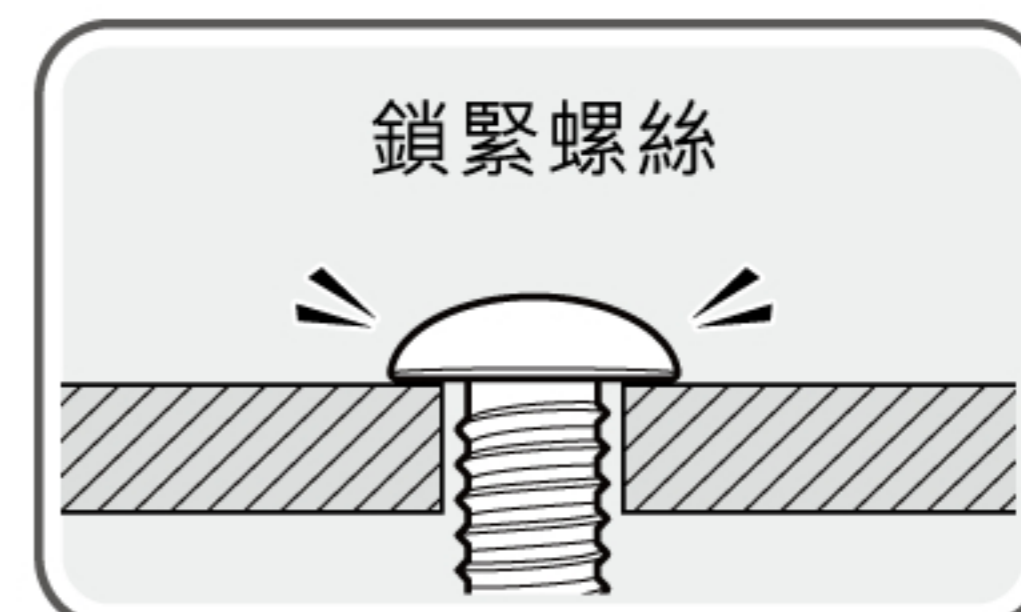



3

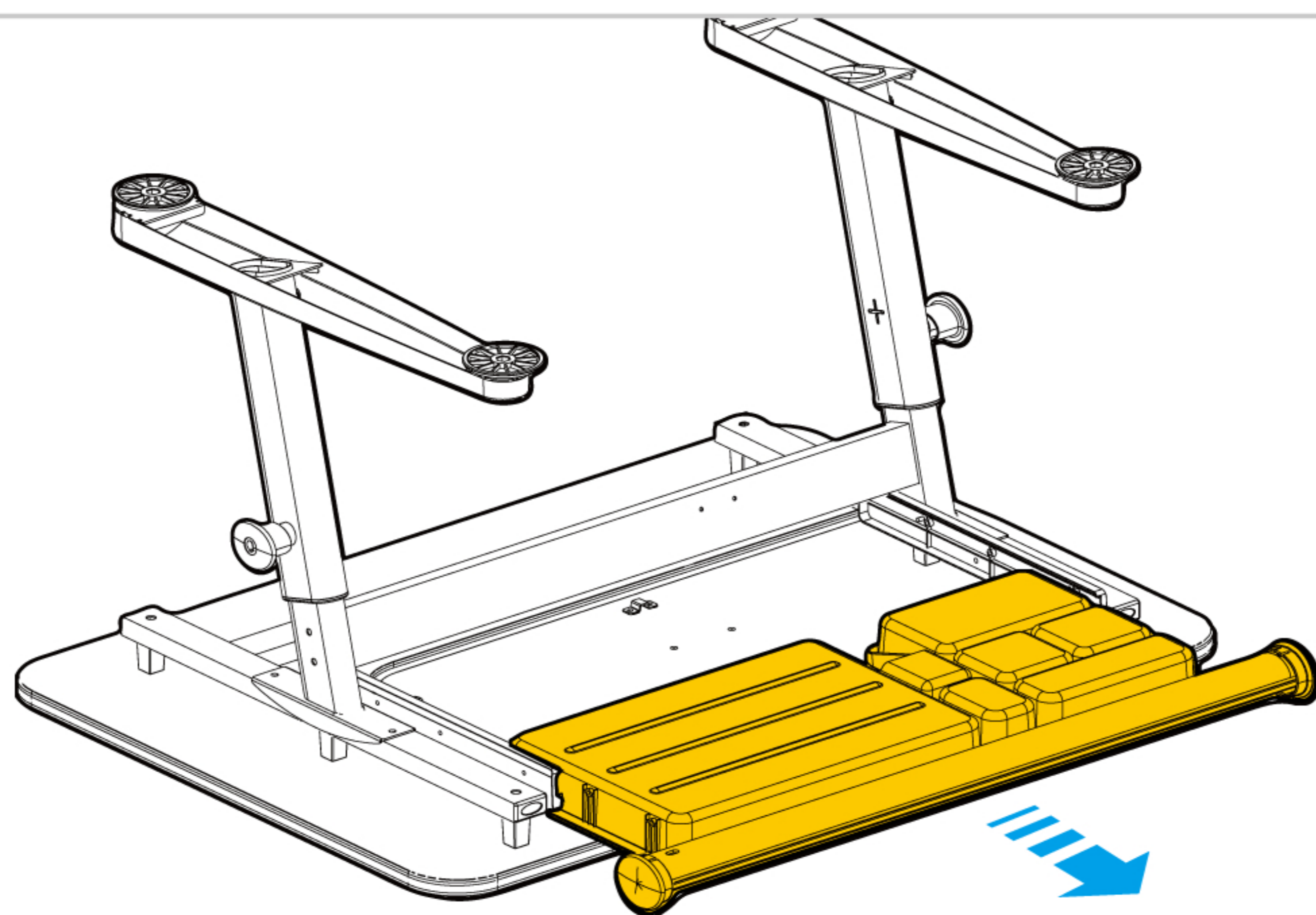

4

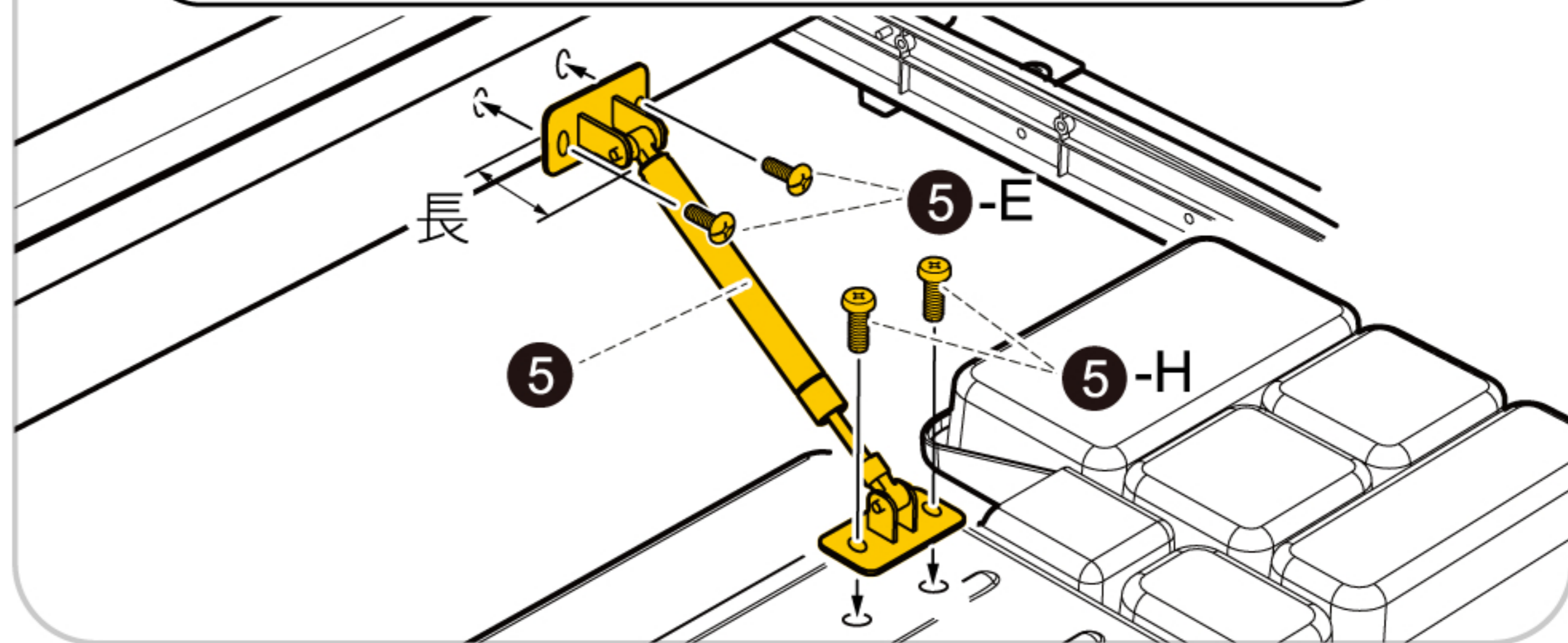
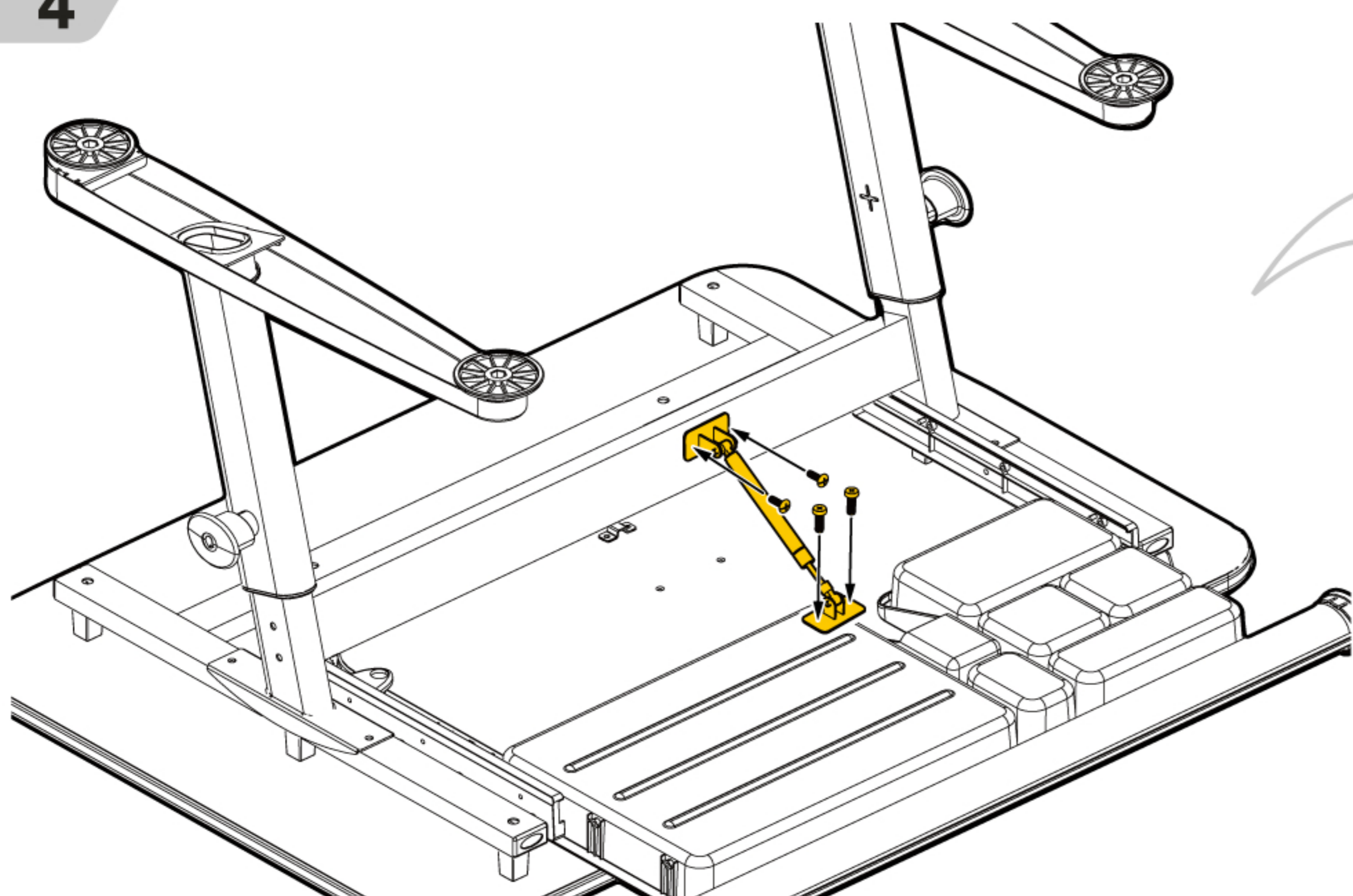

5

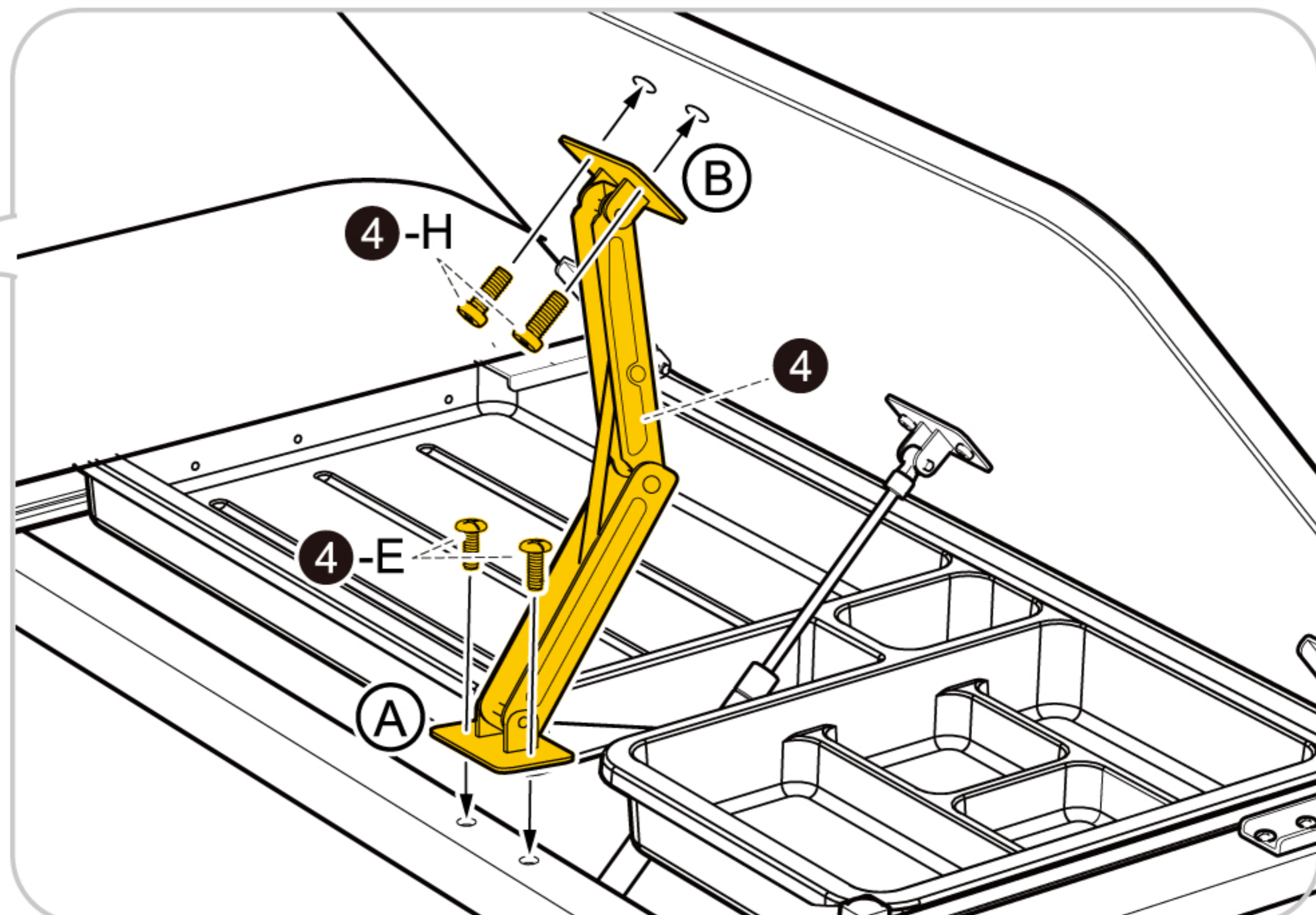
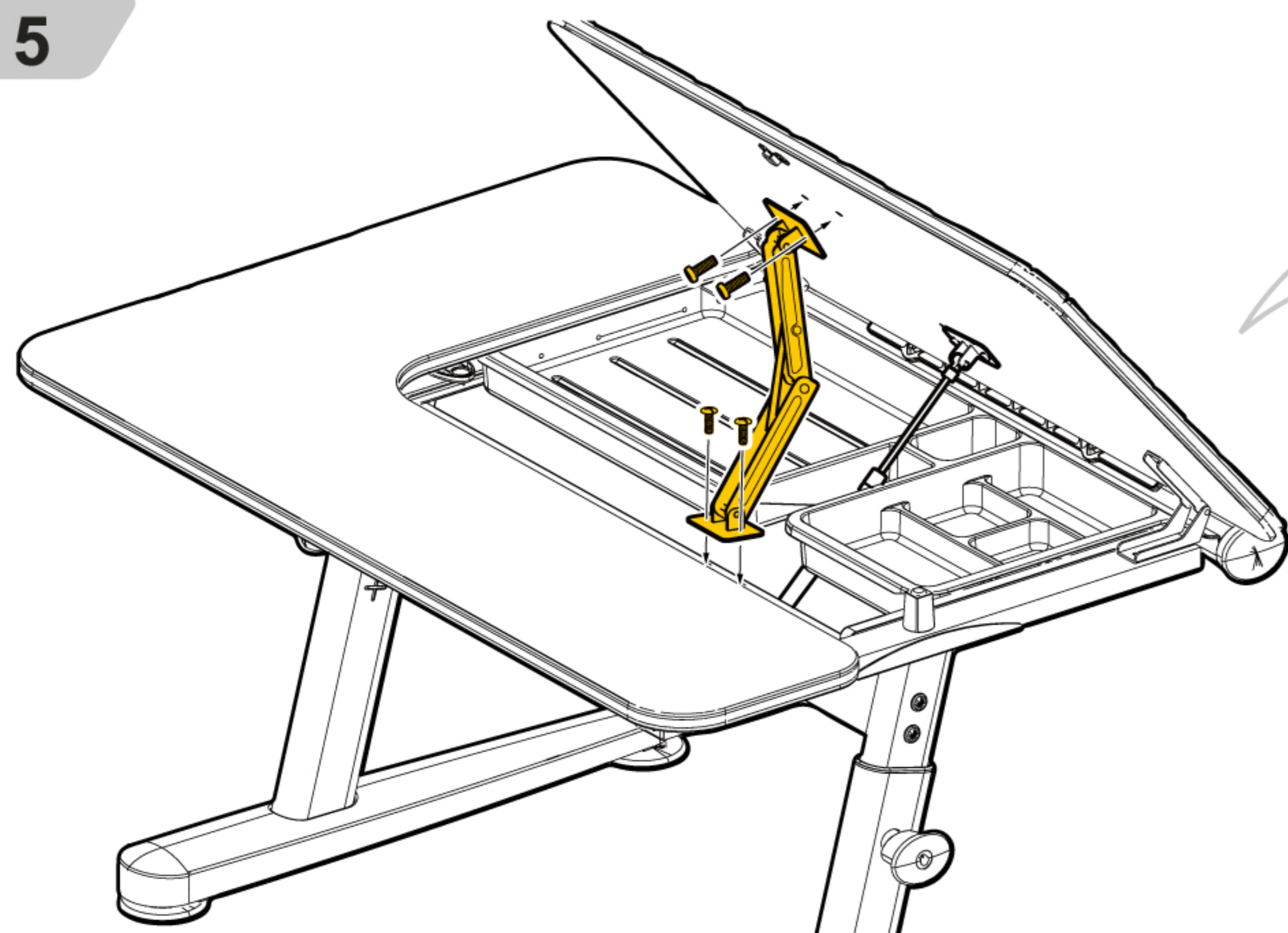

6

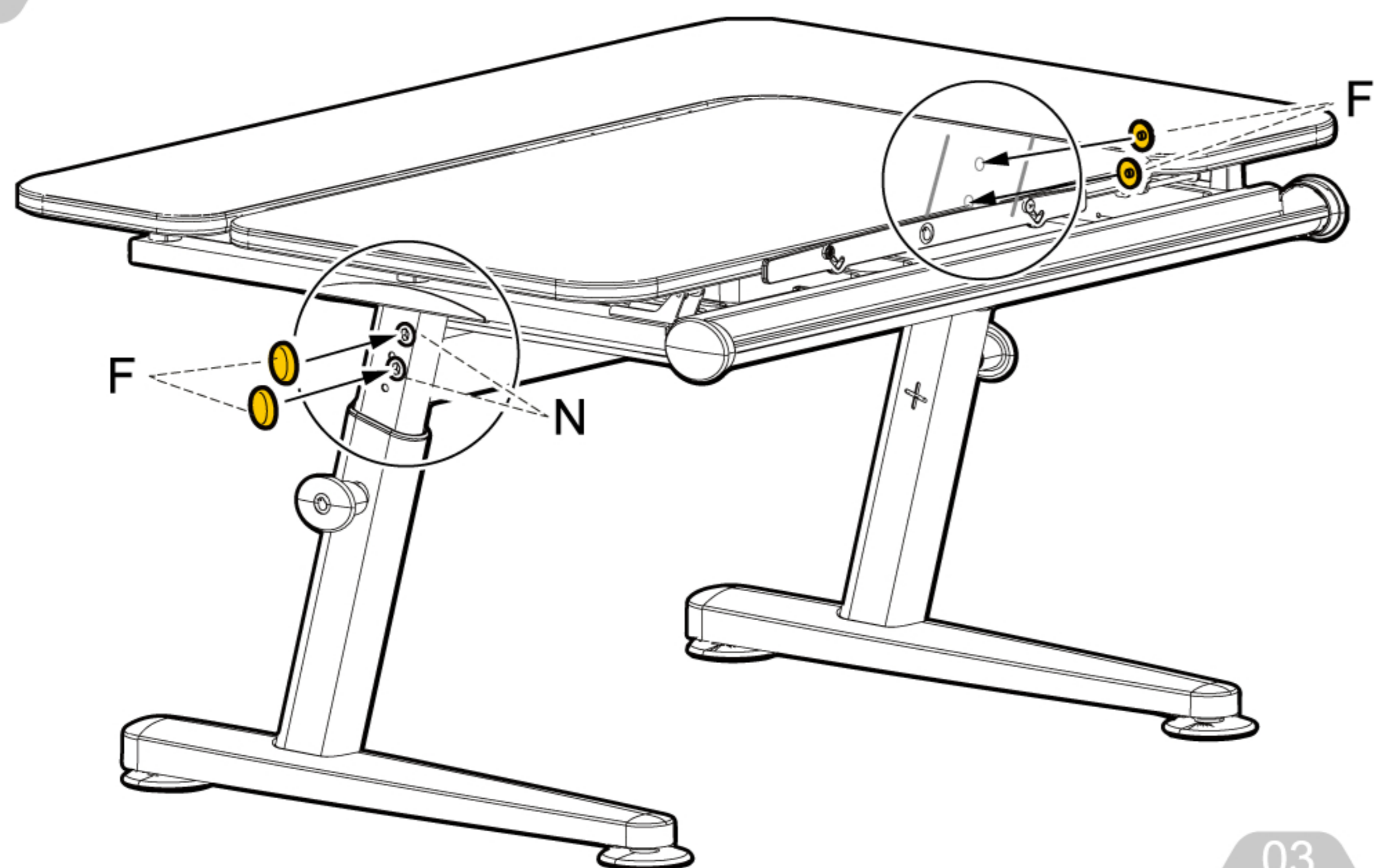

特別說明

1. 確認步驟 2 → 螺絲 M 是否牢固鎖緊。
2. 再將步驟 6 → 螺絲 N 鎖緊並蓋上螺絲蓋 F。

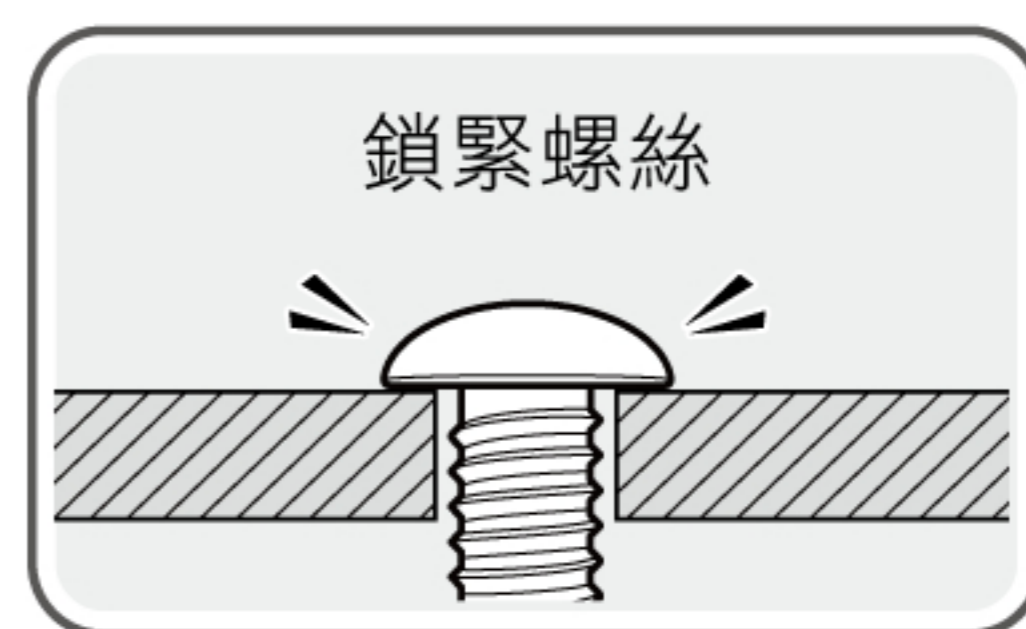



## 高度調整

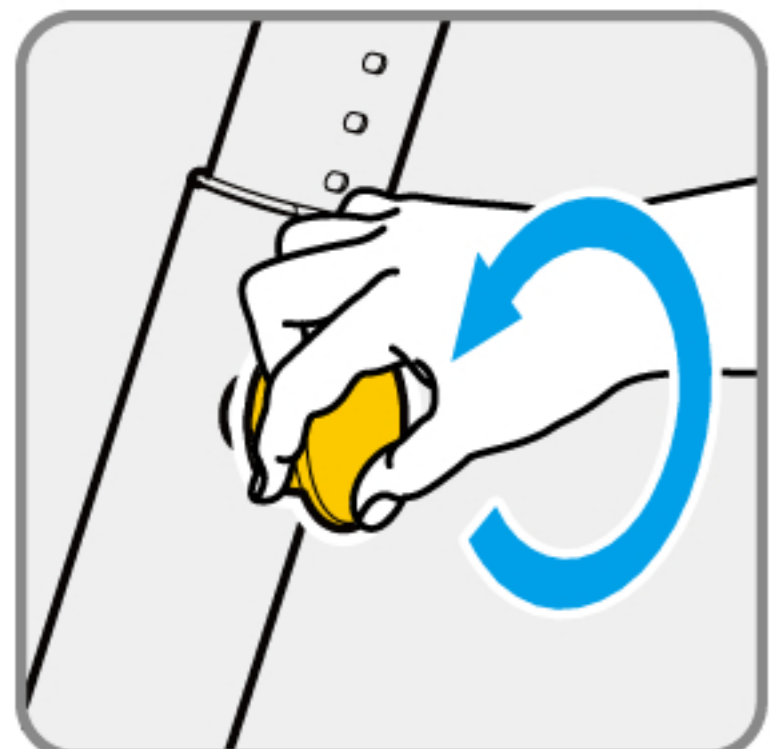

1. 逆時針鬆開把手。

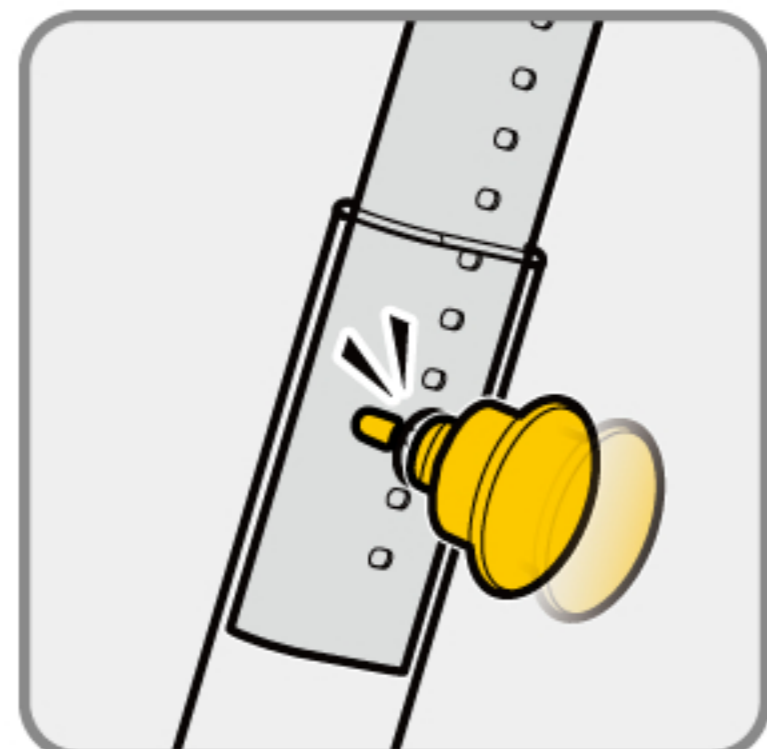

4. 放開把手並確定插入調整孔。

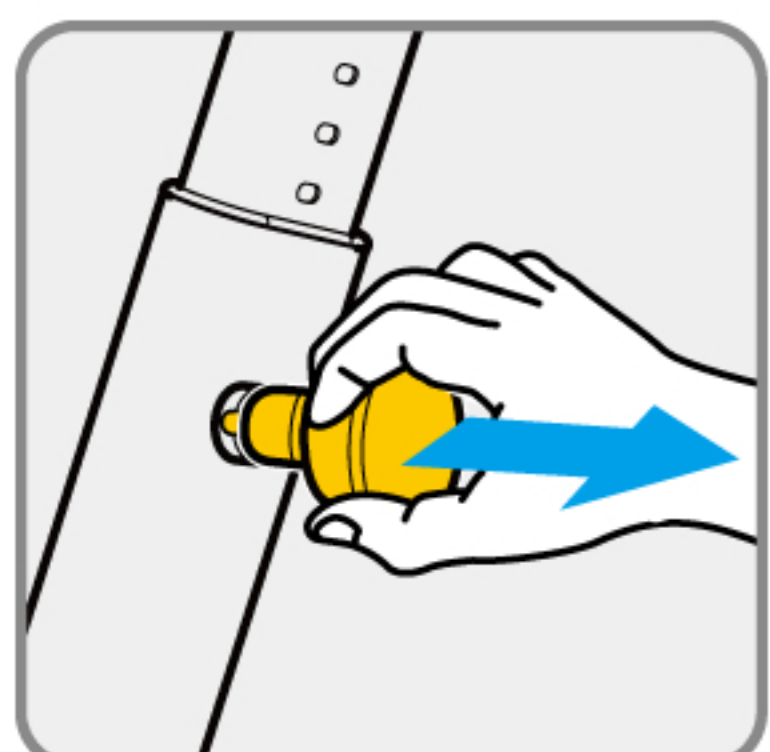

2. 將把手向外拉開。

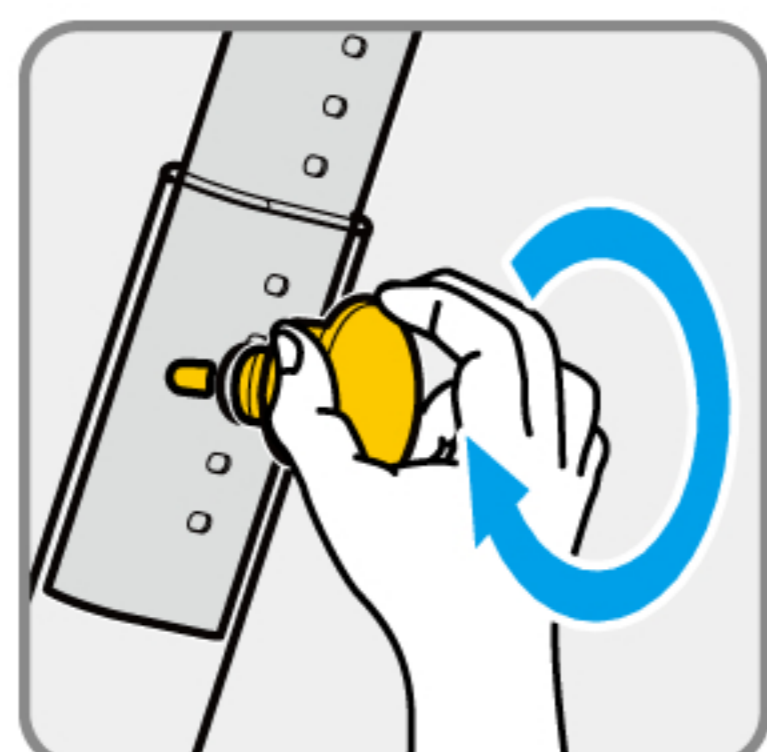

5. 順時針鎖緊把手。

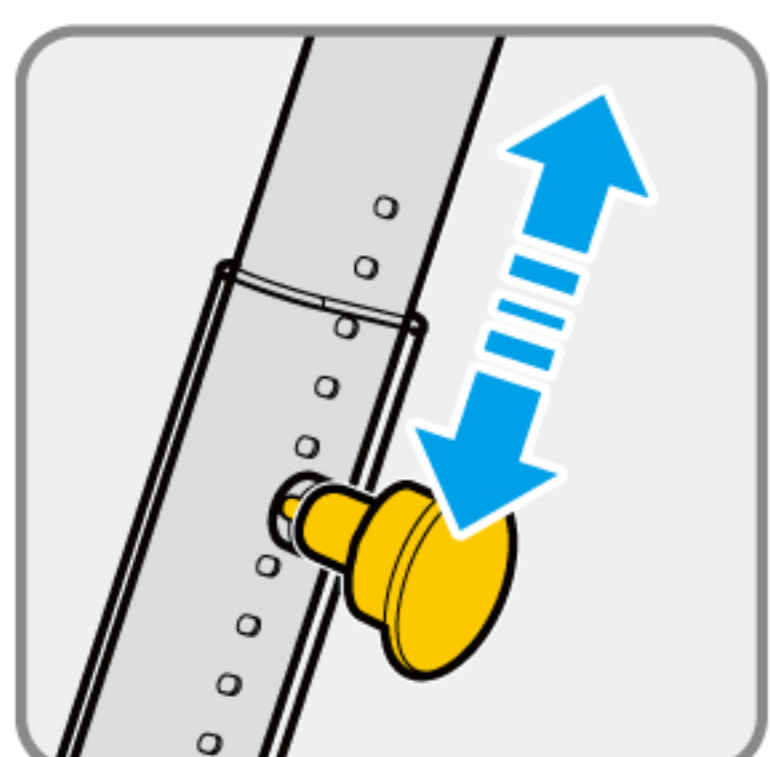

3. 調整桌腳至適當高度。

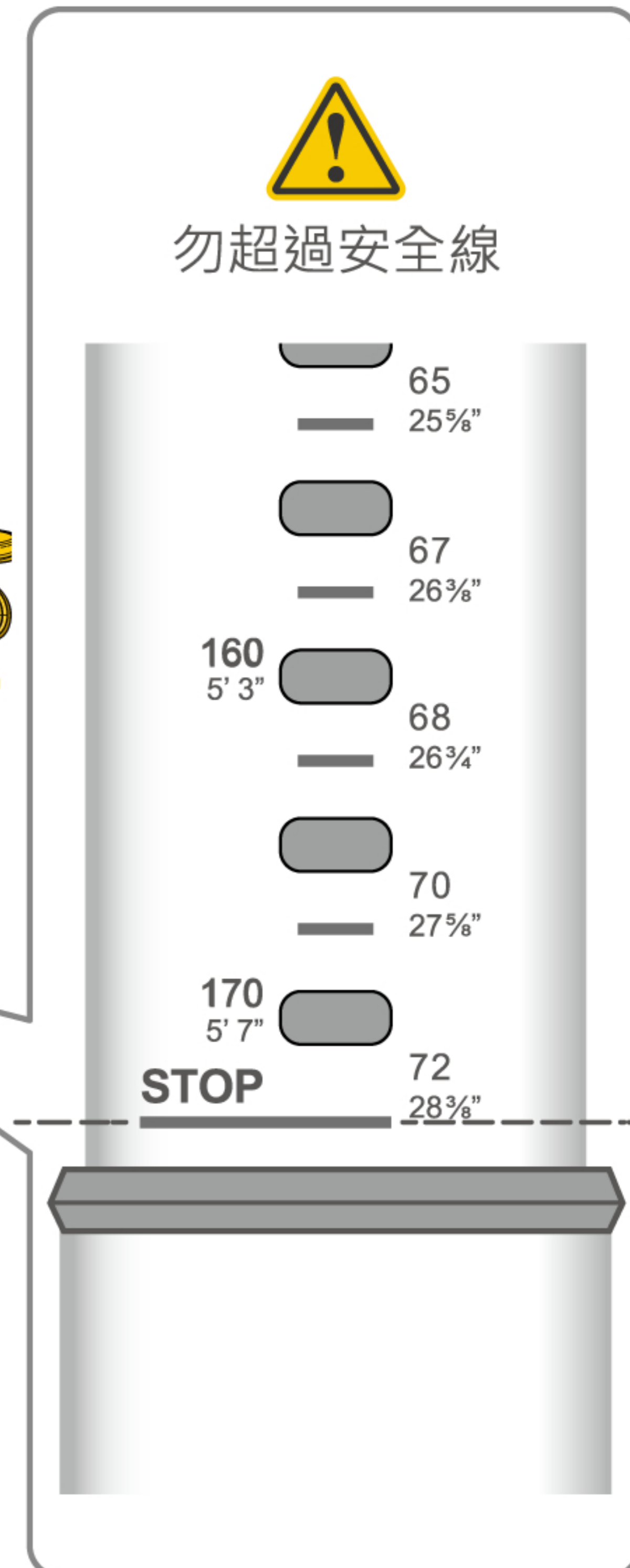
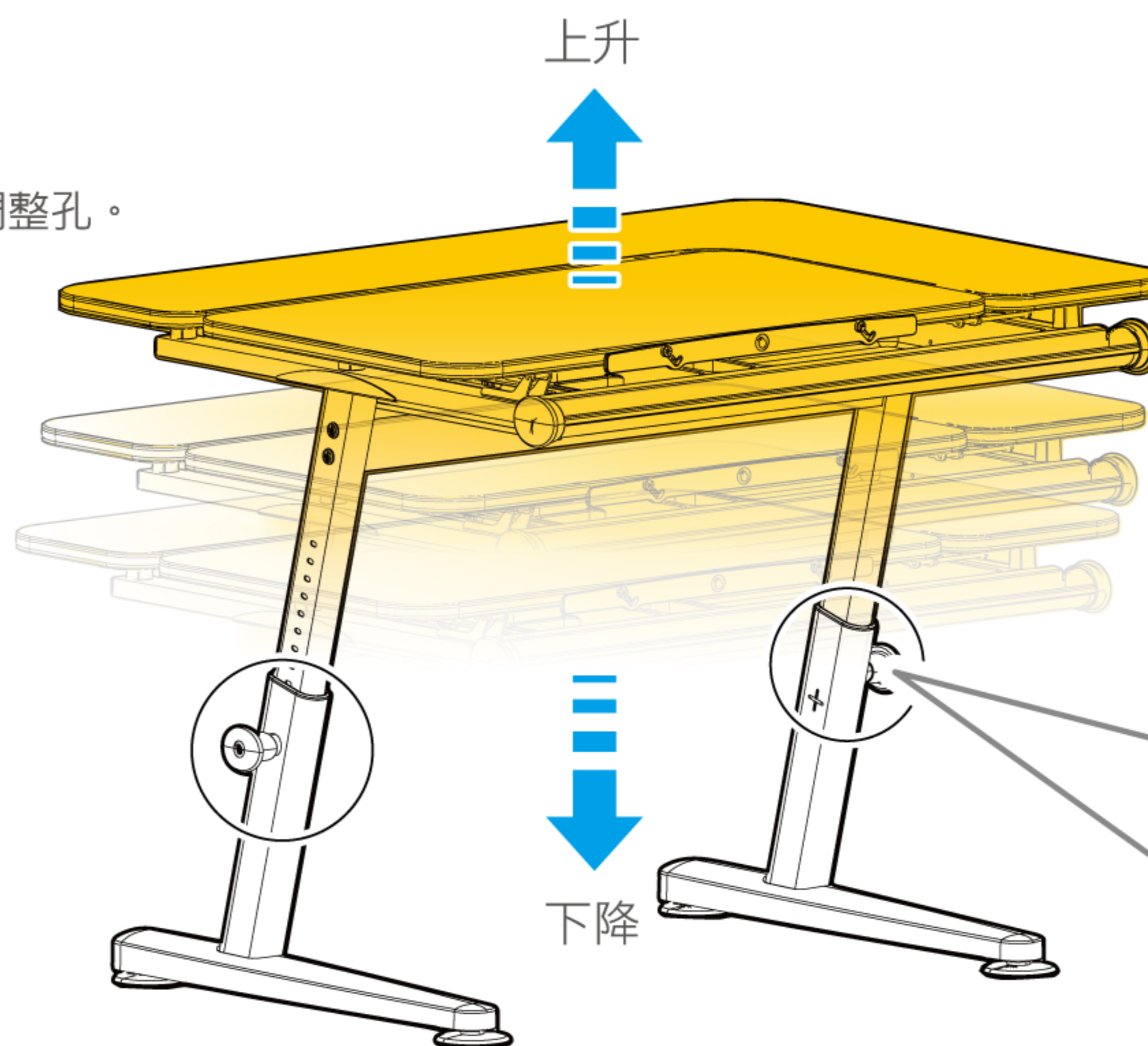

## 角度調整

調整桌板至合適角度

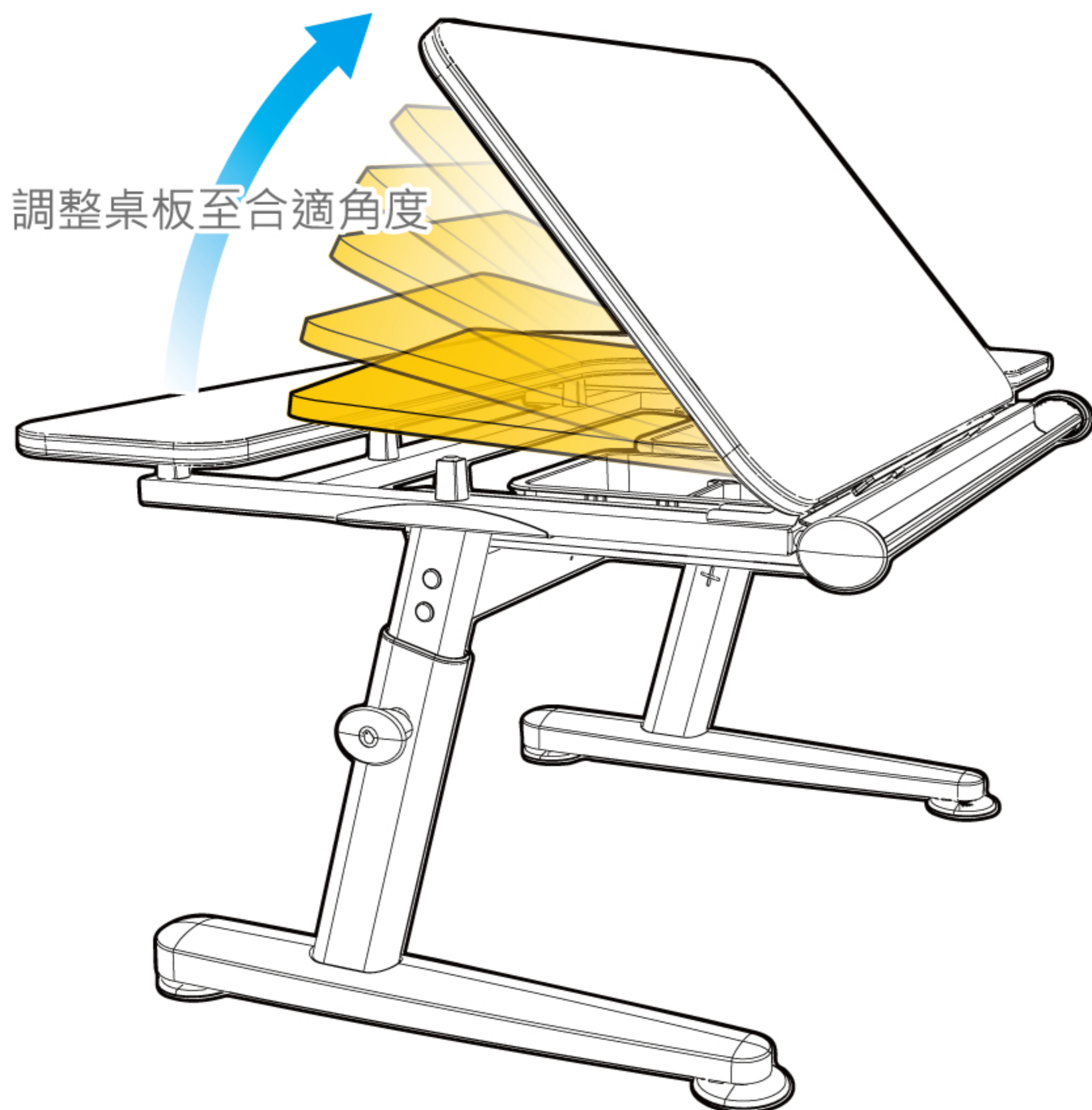

1. 將桌板拉到底

2. 放開即可回到平面

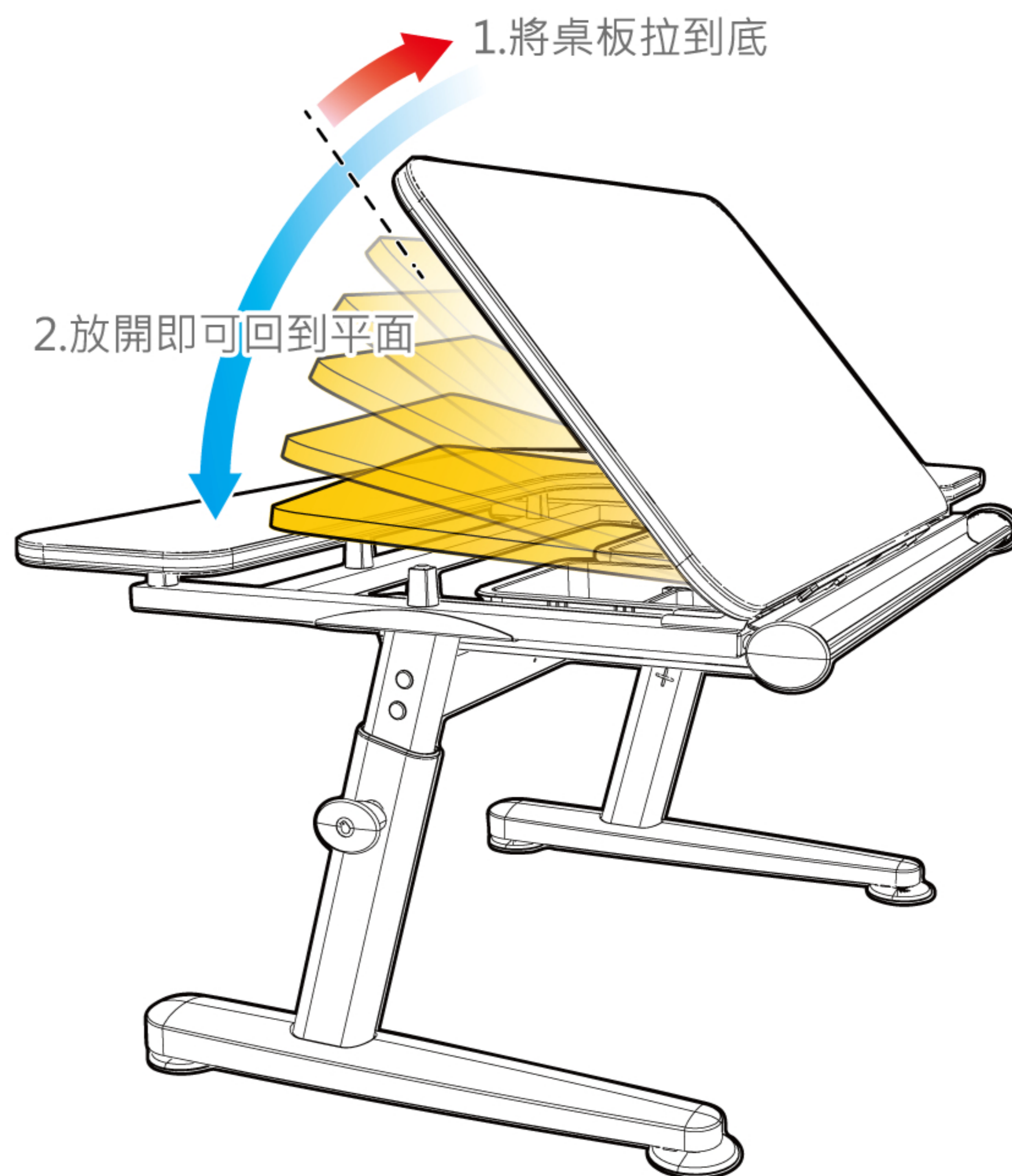

## 大將作中華地區客服專線

台灣地區

免費專線：0800-628 666

客服時間：08:00~19:00 (週一~週五)

Line ID：kid2youth1

客服Email：help@tctnano.com

大陸地區

官方客服：400 609 0809



官方微博



微信客服



官方網站



## A. 什麼是品質保證10+5+1？

所有Kid2Youth 商品皆經過測試，於一般家庭日常生活下為標準，都能符合本公司對品質及耐用度的嚴格要求，並以不同的零組件區分為10年、5年、1年。每項產品及零件提供的品質保證及保固期限，自收貨日期或組裝日期起生效，購買時我們會有專員為您啟動線上保固。當原購買者轉售或轉讓該商品時，即為保固期限的終止期。顧客需要保固服務時，請出示原始購買發票或蓋有本公司店章之品質保證書，以本人或是出示身分證明文件，保固服務方可生效。故請妥善保存品質保證書及發票以利享有品質保證服務。

## B. 品質保證涵蓋範圍

10年品質保證涵蓋範圍：Kid2Youth所採用之STABILUS氣壓棒本體。

5年品質保證涵蓋範圍：Kid2Youth所採用之主、副結構，如桌椅櫃本體及五金部。

1年品質保證涵蓋範圍：Kid2Youth所採用之損耗品結構，如書包、T5燈、PU輪腳、布面等。

(詳細品質保證服務條約內容請參閱D、E項)

## C. 維修申報

1.於大將作官網www.kid2youth.com底部的『聯絡我們』中填寫表格描述故障原因並附上故障照片，我們會有專人與您聯絡。

2.我們將於3日內回覆您維修方式與所需時間(請參閱品質保證與服務內容)。

3.台灣以外地區維修申報與品質保固流程請洽當地經銷商。

## D. 產品保固及品質保證服務內容

1.Kid2Youth收到維修單後3個工作天內會有專員立即為您服務。(僅限台灣地區)

2.總公司在收到維修單後將交給品保部門檢視商品損害情況，並主動聯繫您是否符合商品保固的條件。

3.若符合保固條件，我們將會另行告知維修時間，並以原廠零件進行維修或是以相同或同等級之商品替換。

4.若商品符合保固的條件，在不需支出特殊費用即可到府維修的狀況下，我們將負擔維修、替換零件、服務人員的費用工資。

5.如果商品不符合保固條件，判定因人為因素造成損壞，大將作將主動聯繫並同時報價詢問維修意願。

6.產品送修運費由買家承擔，如判定非人為因素損壞，回寄的運費由大將作承擔，如判定為人為因素損壞，回寄的運費將由買家承擔。

7.商品保固不適用於未經Kid2Youth總公司授權的維修工作。

8.原商品零件一經替換，該原商品零件所有權即為Kid2Youth所有。

9.如果Kid2Youth不再銷售該商品，我們將提供適合的替代商品為您更換。

10.台灣以外地區維修申報與品質保固流程請洽當地經銷商。

## E. 哪些狀況下無法得到產品保固及品質保證

1.產品保固不包含正常性損耗如碰撞，切割，或不當人為操作等。

2.商品若放置於室外或潮濕的環境，不適用於本商品保固。

3.商品保固不適用於自行拆除、搬移或修補商品而造成的毀損。

4.商品保固不適用於天災、人為或意外事件所造成的毀壞。

5.未按操作使用說明所造成之的損壞即視為人為因素損害。

6.產品保固不適用於表面因時間引起的色澤差異。

7.展示品及原廠特賣，所購買的商品不在保固範圍內。

8.品質保證只涵蓋原始購買人，權益不得轉讓。

9.品質保證書內未加蓋本公司店章或無法提示購買證明，如發票者。

10.Kid2Youth保留修正此品質保證條款與細則之權利。

## F. 產品使用與保養指南

1.操作產品前應先詳細閱讀操作手冊與產品說明書。

2.不自行拆裝產品結構避免產品損壞而失去品質保證服務。

3.應定期檢查關節部件並施以潤滑。

4.氣壓結構產品應定期解鎖並調整高低數次以保持順暢度。

5.於使用數週後用包裝內專業工具將螺絲鎖緊並逐年檢查螺絲緊度數次。

6.使用拉鍊時請一手握住拉鍊起始點一手握住拉鍊扣，順著拉鍊方向移動。

如有卡住情形，請避免用力拉扯，反方向移動後再順著拉鍊方向移動即可。

7.清潔任何表面不可使用侵蝕性清潔劑或粗糙表面物品擦拭，請用40度以下

溫水與清潔劑沾水擦拭，並隨後用乾布擦乾，保持乾燥(金屬活動結構請定期施加潤滑劑保養，勿用清水擦拭)。

## 疑難排除

### 剛組裝好就無法順利調整升降？

請先檢查桌面是否放物品？是否只放在某一個地方（重心會偏離）？

若是時，請先將桌面清空或將東西移到較中間位子，讓重心移至中間，桌面較呈水平，即可正常調整，再將物品移至原來位子即可。

若無時，請先使用水平尺或圓形物體檢查地面與桌面是否呈水平狀態。

若未呈水平，請將所有螺絲鬆開一半，然後做升降的動作，2~3次後壓到底，鎖緊即可正常升降；若已呈水平狀卻無法升降，請填寫維修單，傳回公司，公司將會盡快處理。

### 桌面傾斜至一定角度時而無法固定時？

請使用老虎鉗在無法固定處稍微夾緊即可。如有異聲，請加潤滑油及可消除聲音。

### 使用一段時間桌子無法升降？

請先檢查桌面是否放物品？是否只放在某一個地方？（重心會偏離）？

若是時，請先將桌面清空或將物品移到較中間位子，讓重心移至中間。

若無時，將桌面先往下調整再用手往上支撐，如此循環幾次，即可正常調整；若桌子已在最低點，則直接用手往上撐。調整至所需要高度鎖緊把手後，再將物品移至原來位子即可。



陪孩子一同成長  
Growing together





# M2+/M6+ Assembly Instruction



## CAUTION

- 4 years old up only.
- Assembled by adult.
- Parents' presence with junior users is suggested.

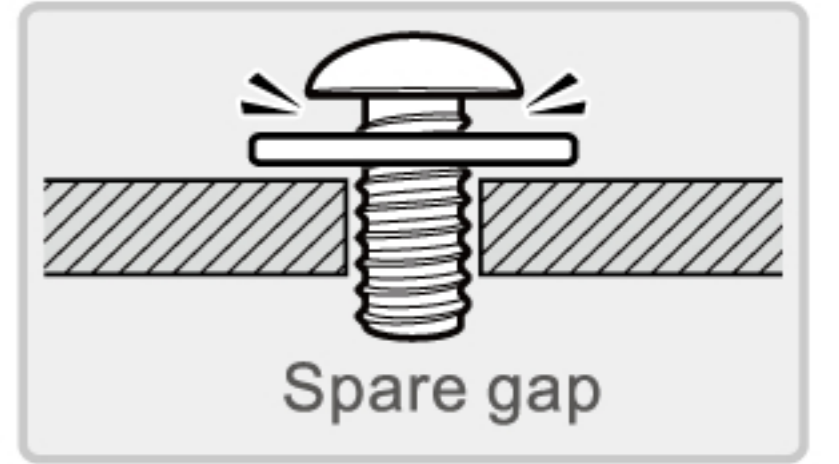
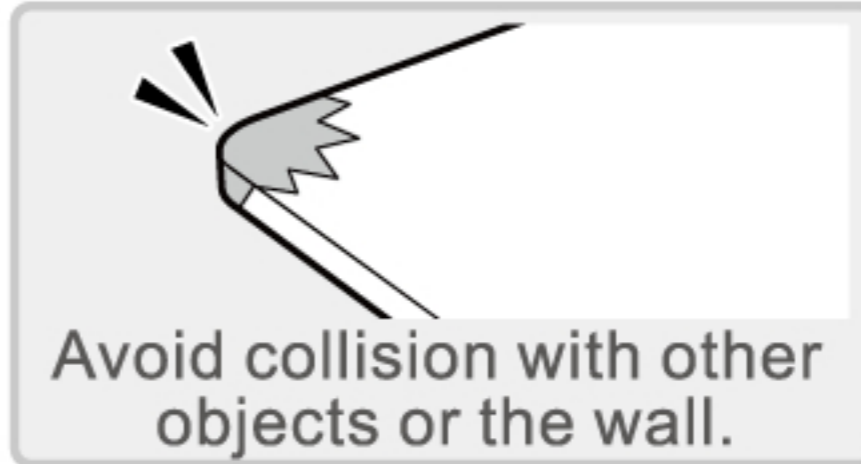

### 1 Desktop

M2+ | XXS

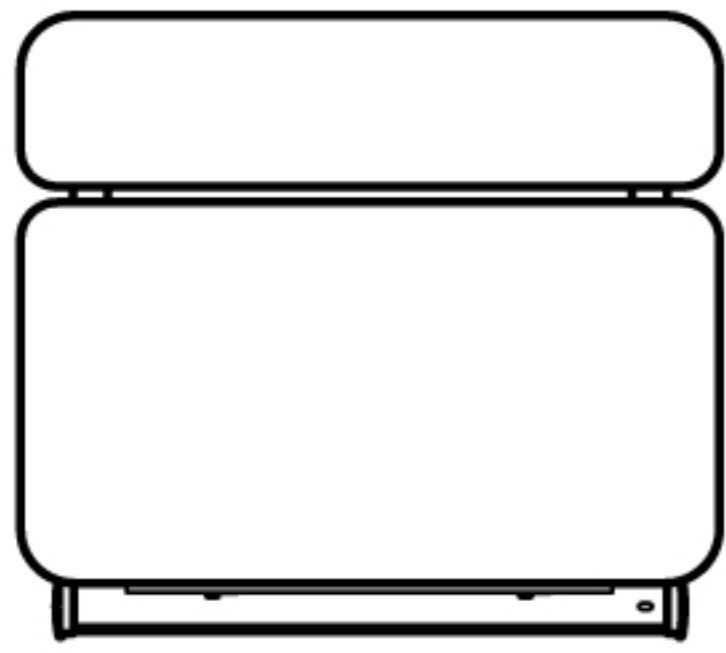

M6+ | XS  
S

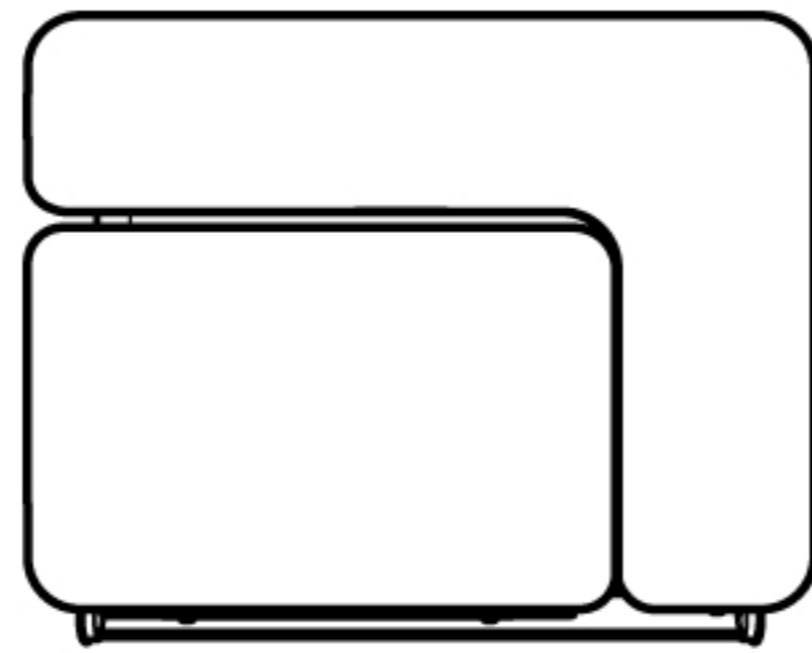

### Parts Kit

M Screws X 4

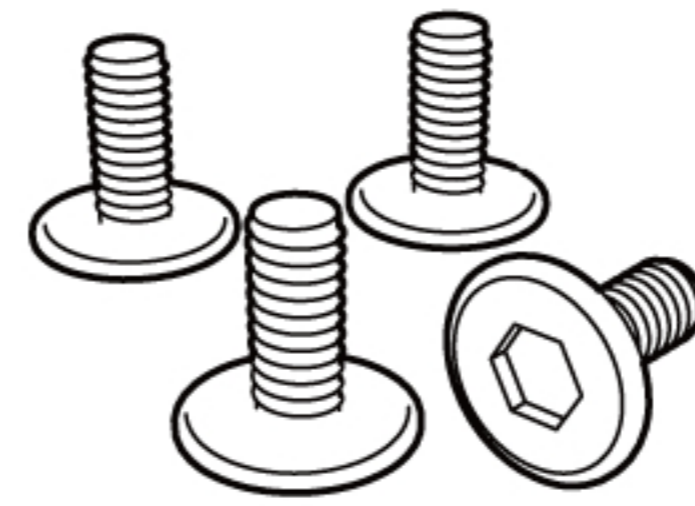

M6\*12mm

N Screws X 4

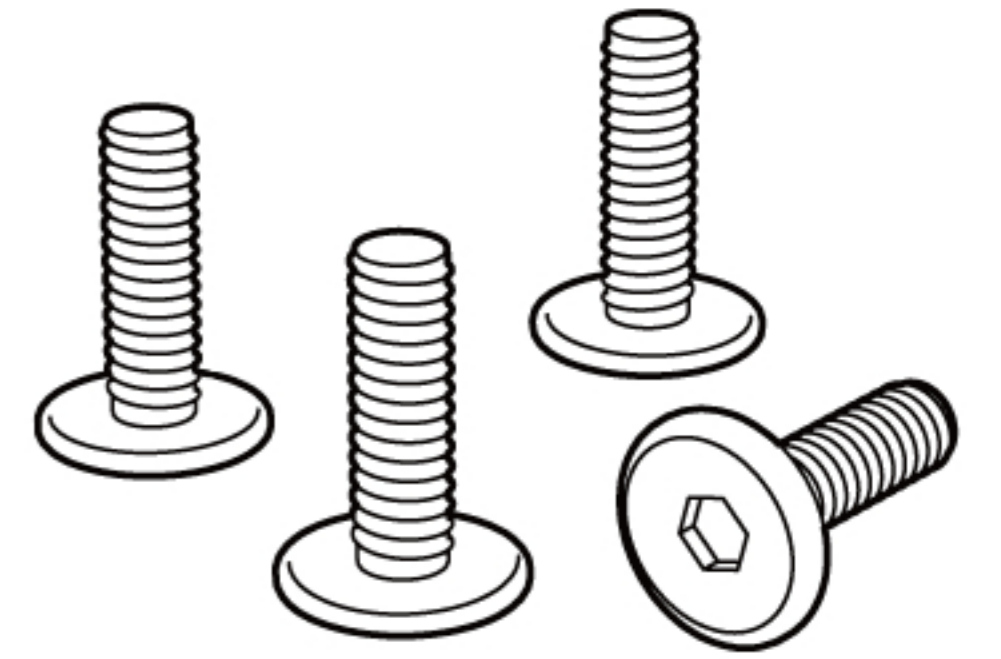

M6\*19mm

### 2 Desk leg

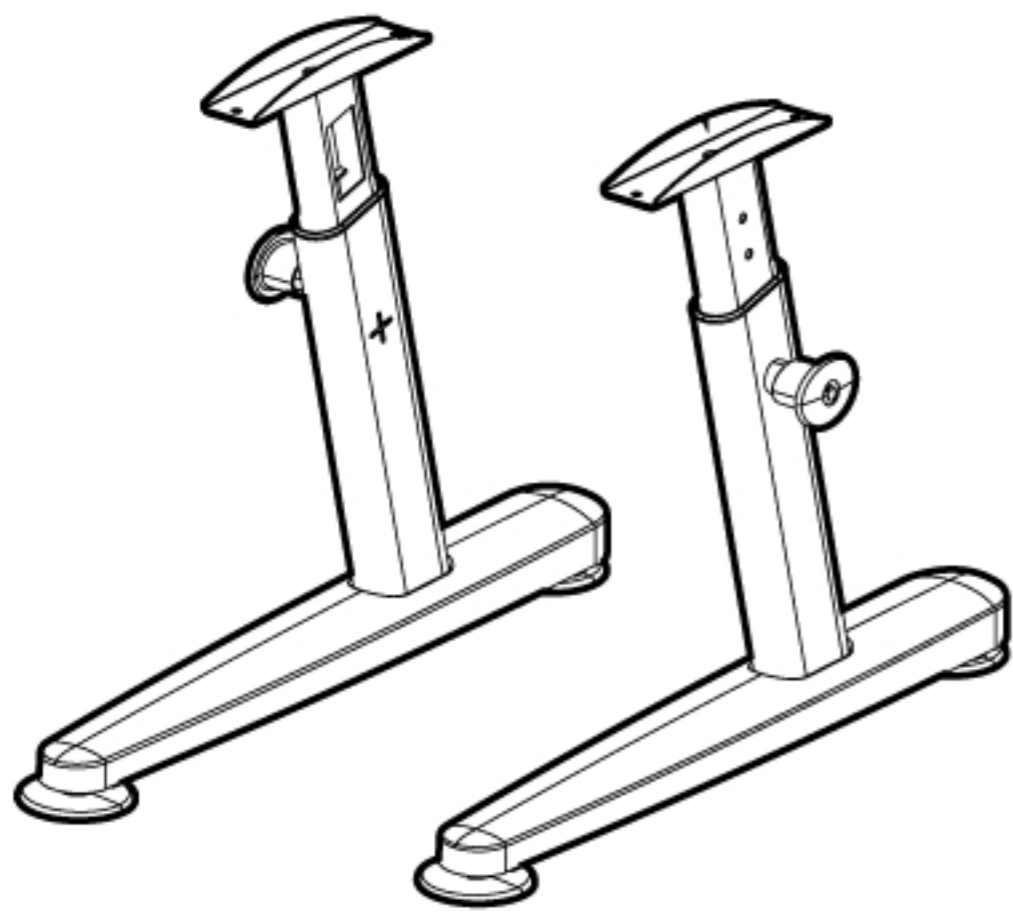

### 3 Middle horizontal shaft

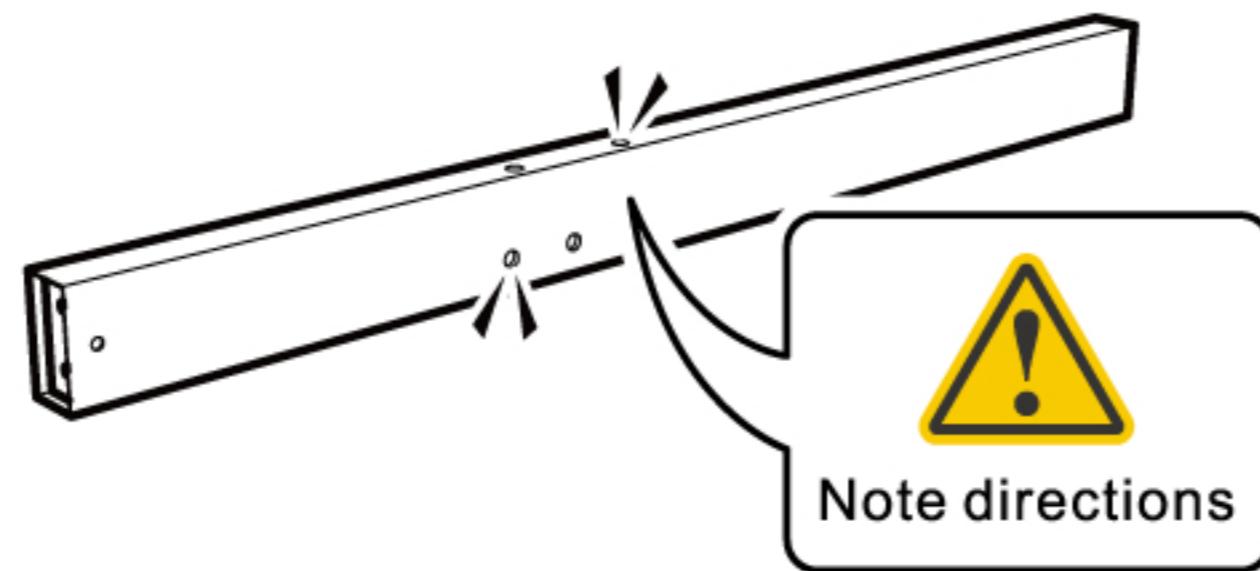

F Caps X 4

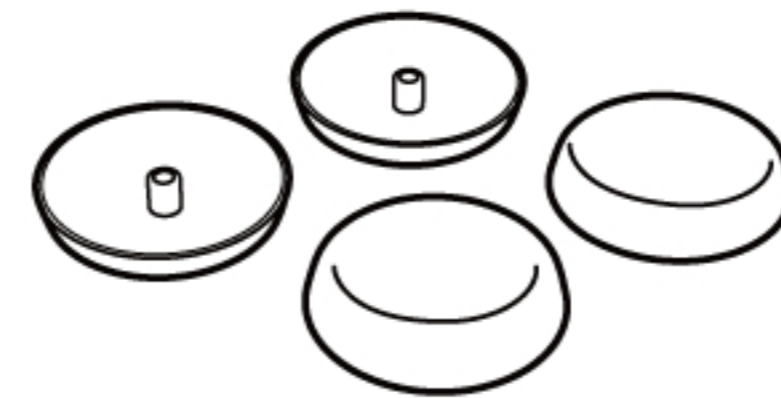

Hex key



NO.4

### 4 Tilt angles bar

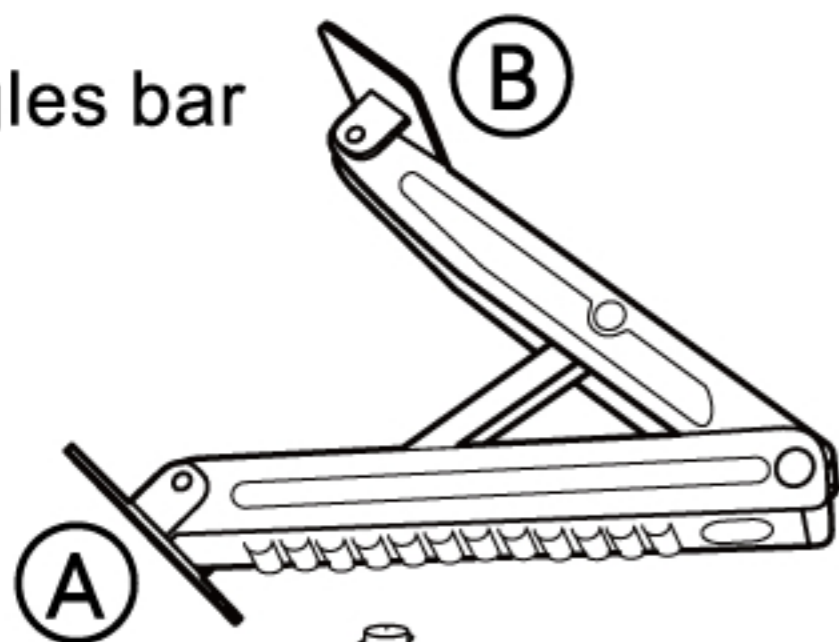

4 -H Screws  
4.8\*14mm

4 -E Screws  
M4\*12mm

### 5 Oil buffer

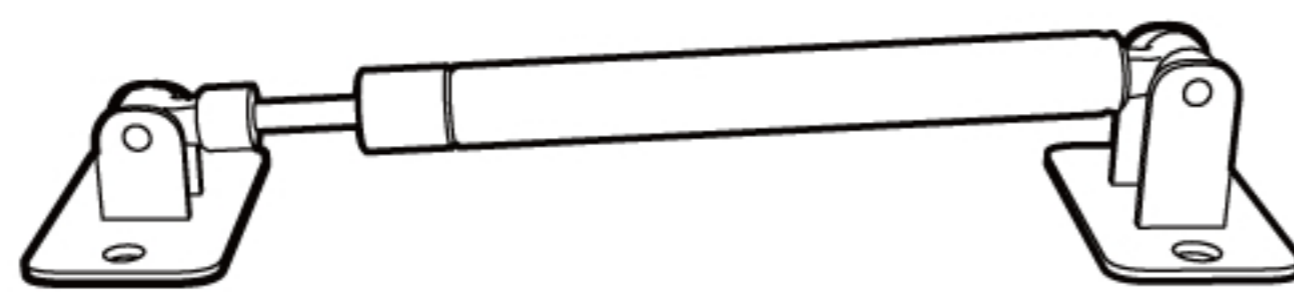

5 -H Screws  
4.8\*14mm

5 -E Screws  
M4\*12mm

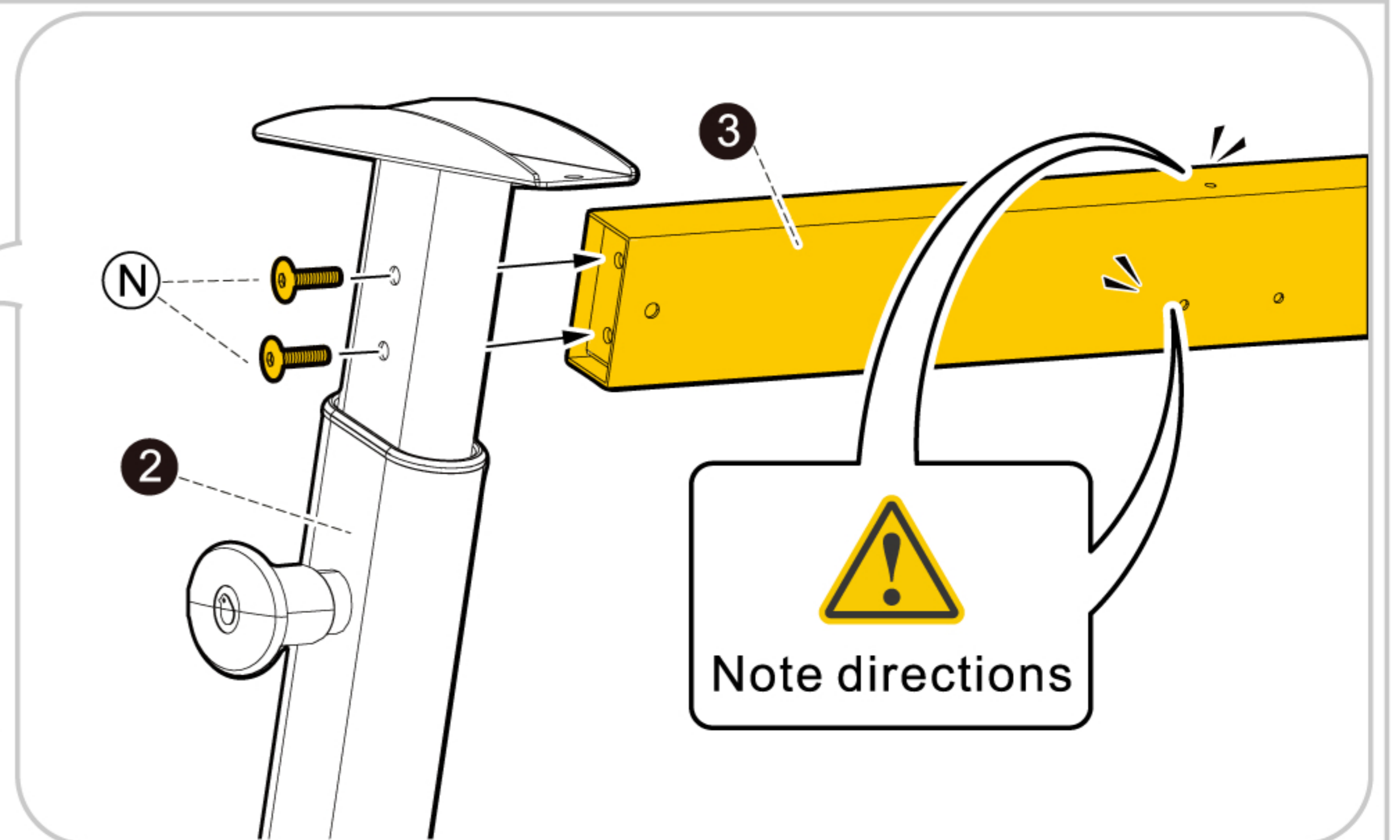
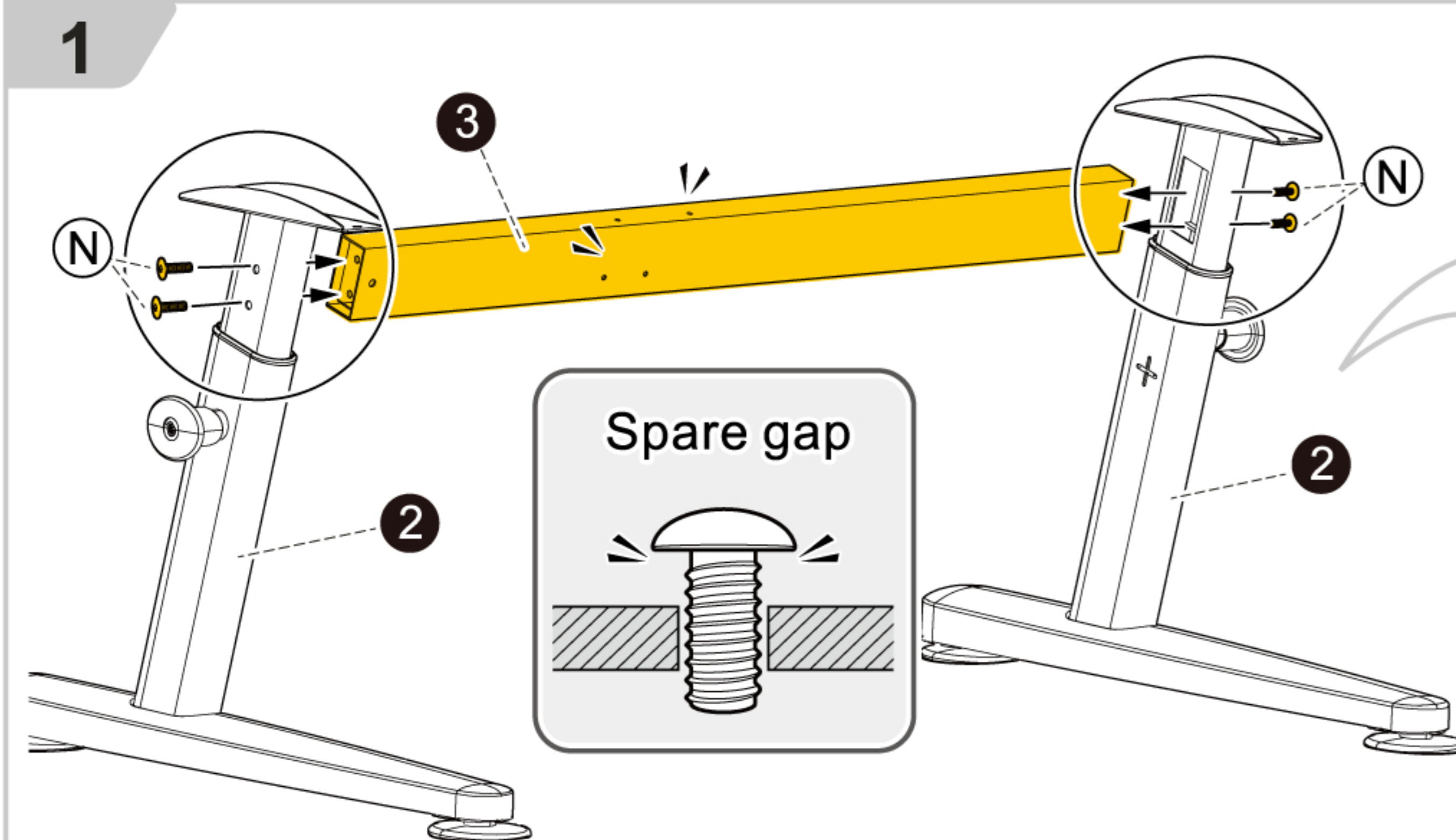

### 2

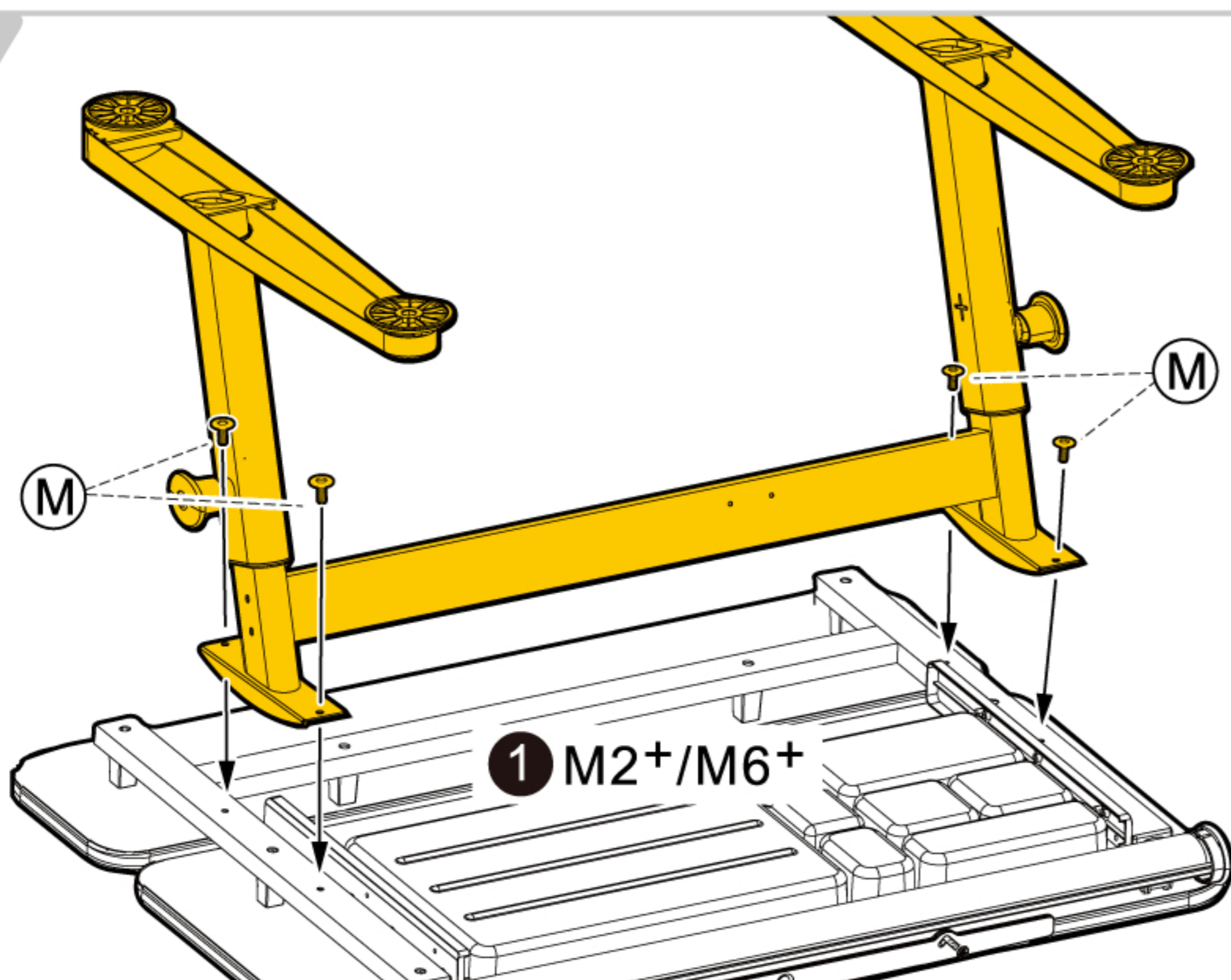

### Note

Step 1. Please check the Left/Right legs are symmetric.

Step 2. Ensure desk leg 2 and middle horizontal shaft 3 are vertical.

Step 3. Fasten screws N tightly

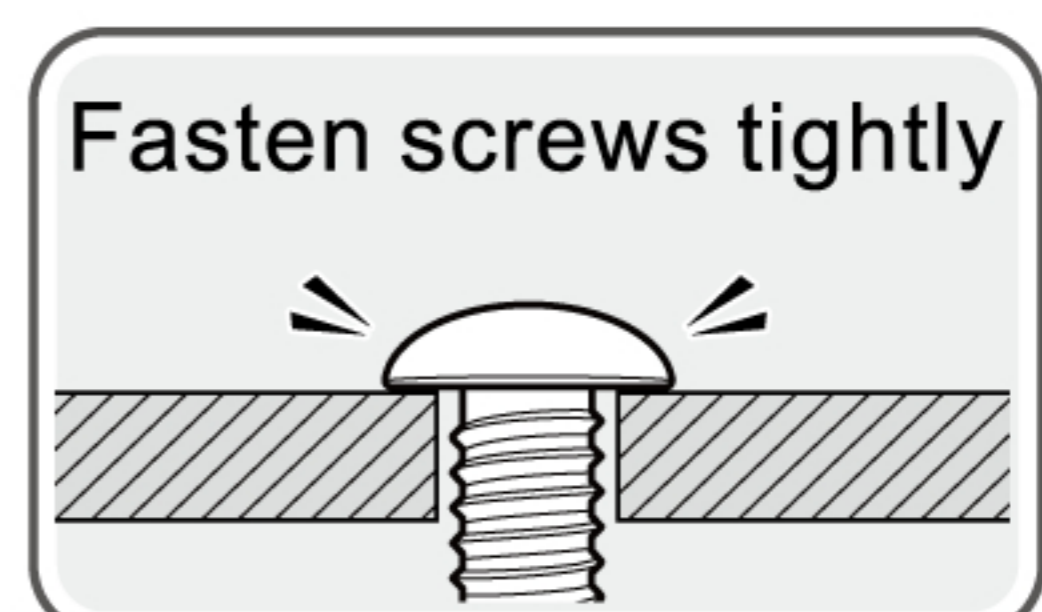



3

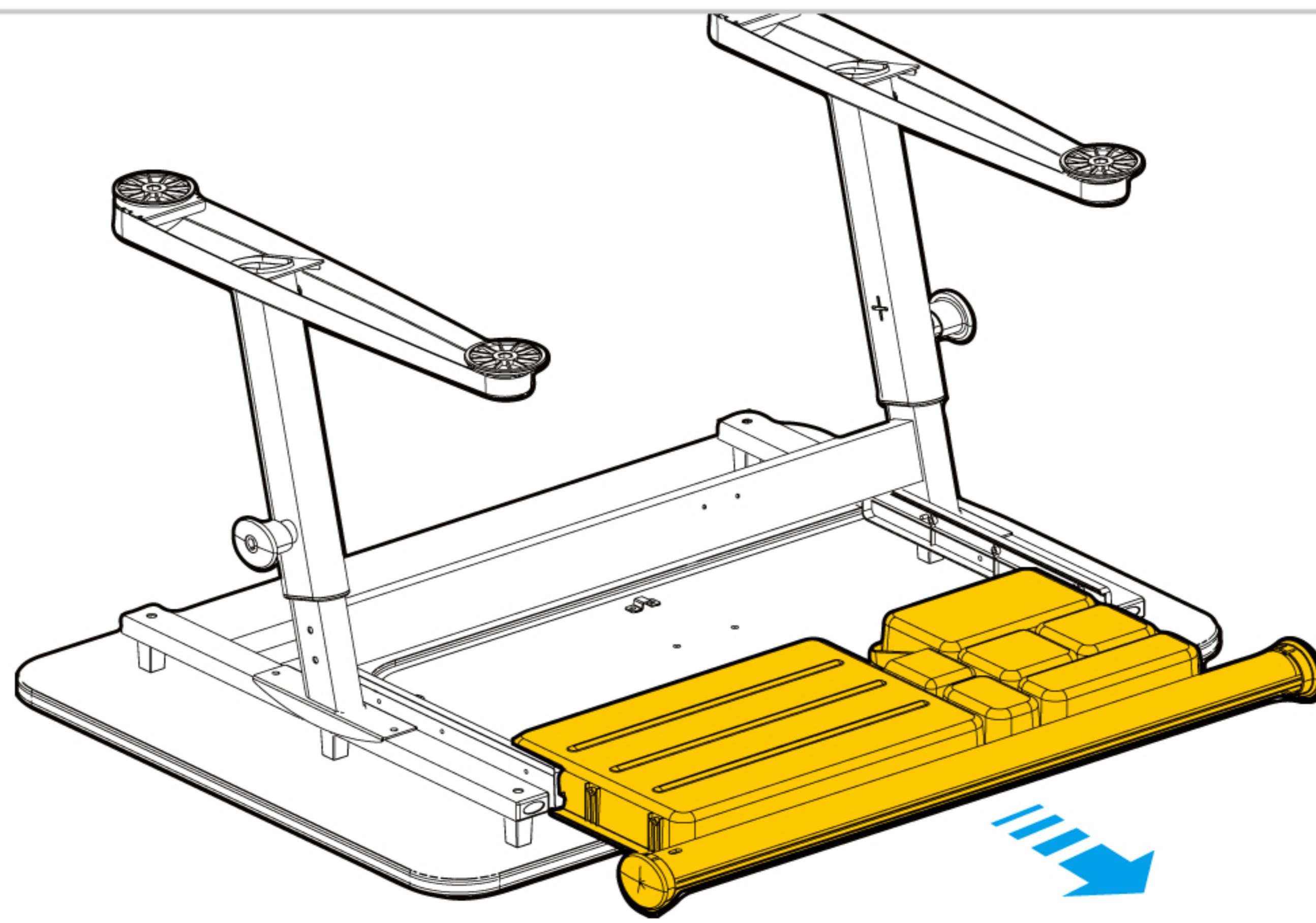

4

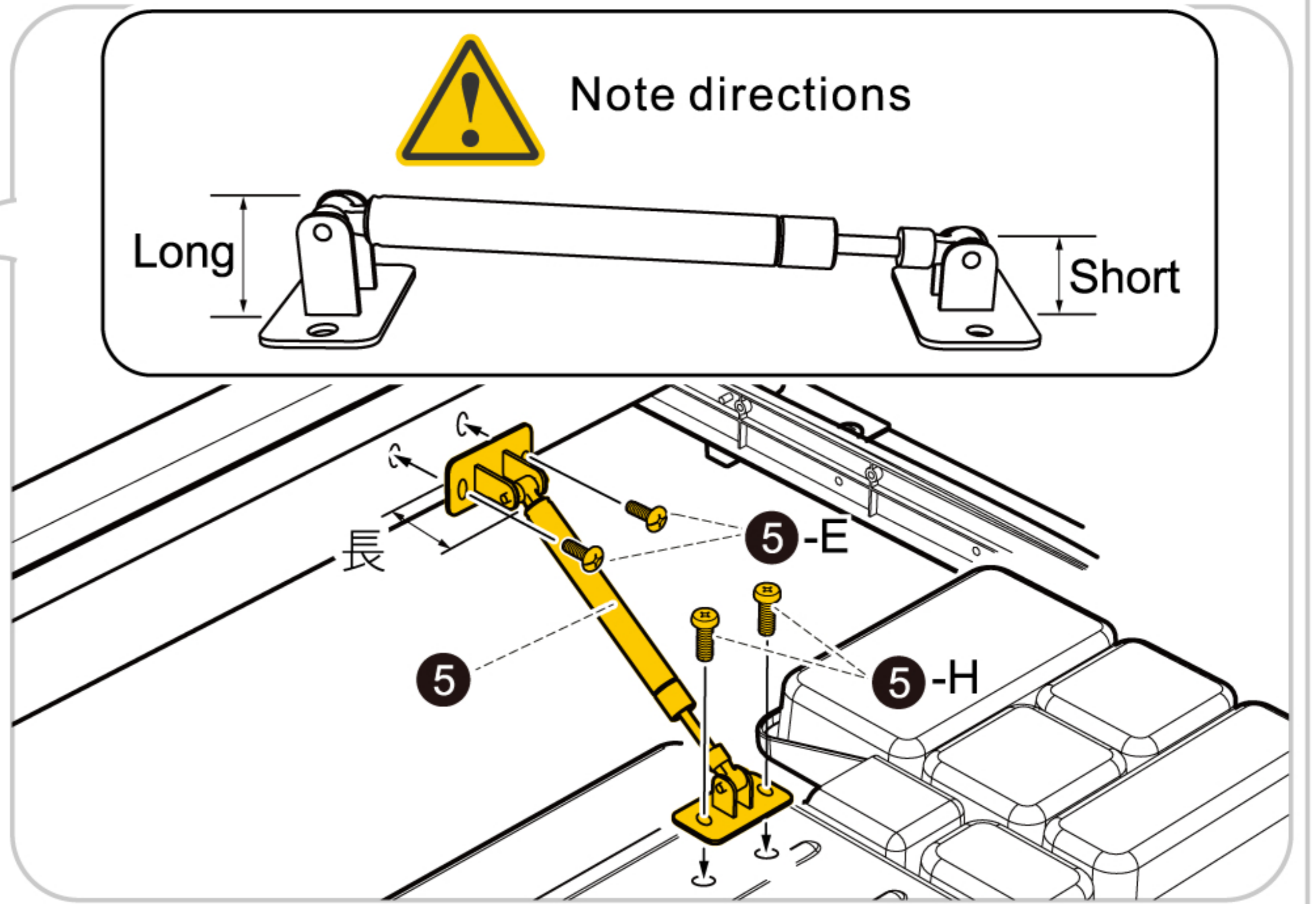
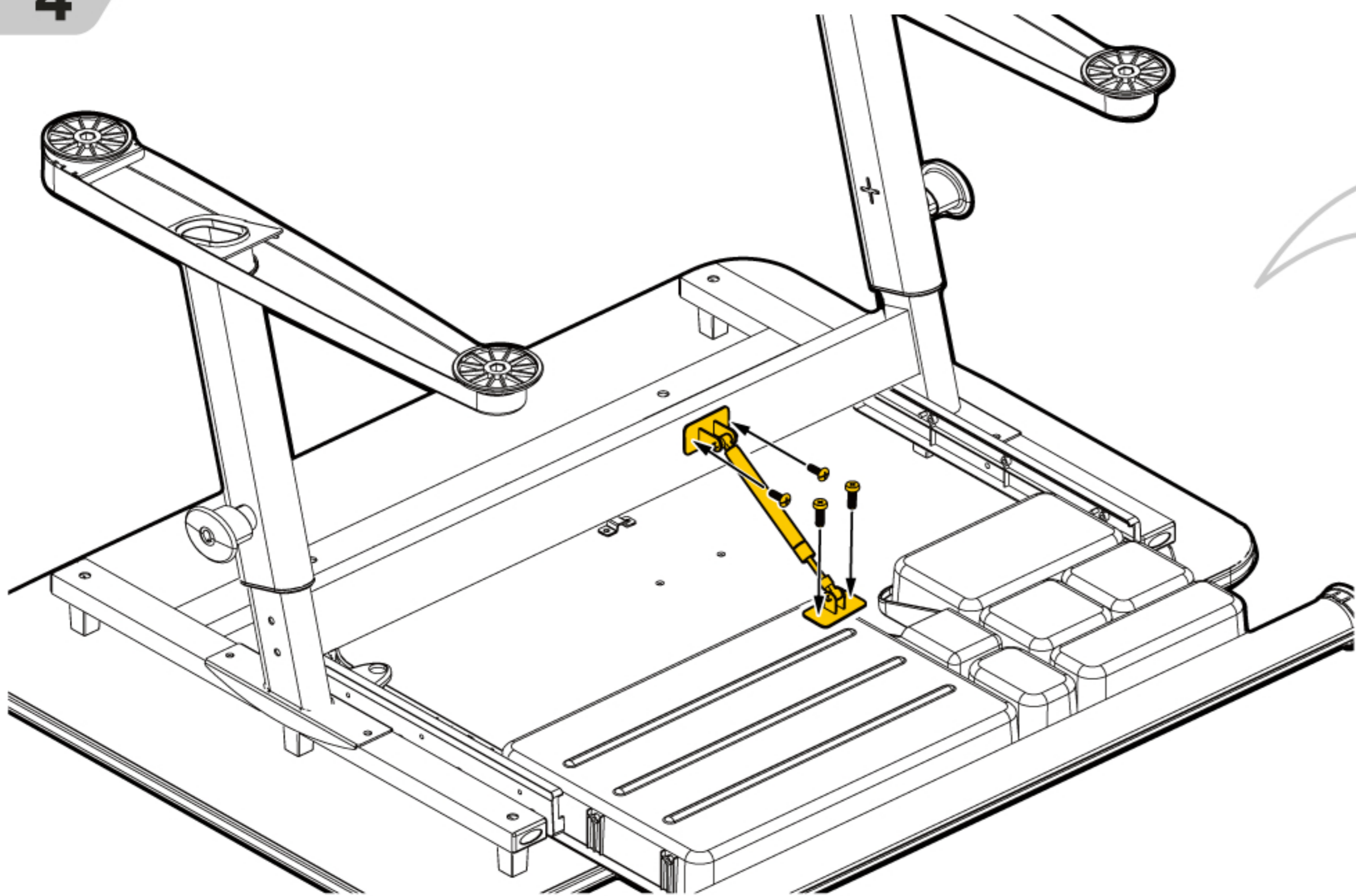

5

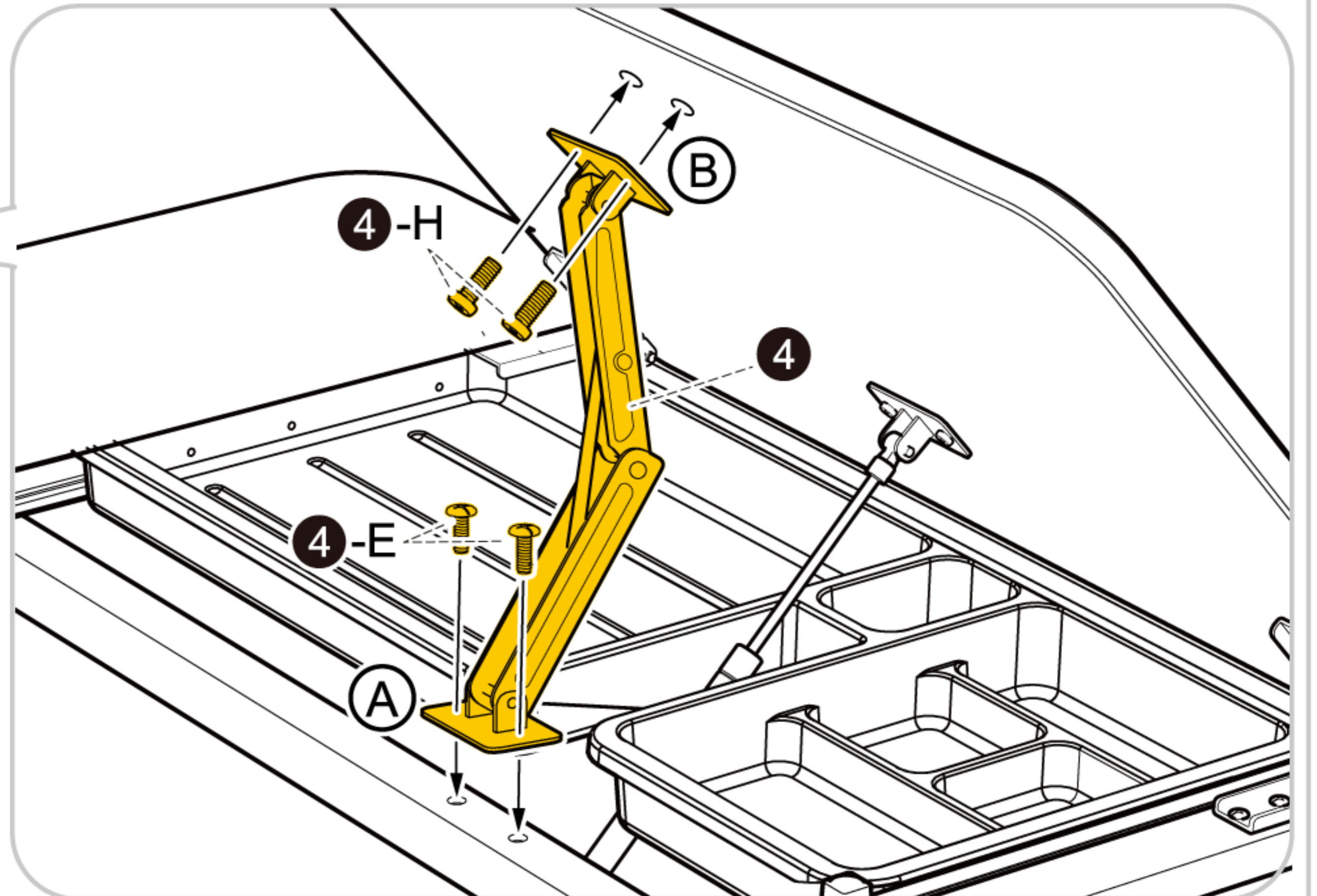
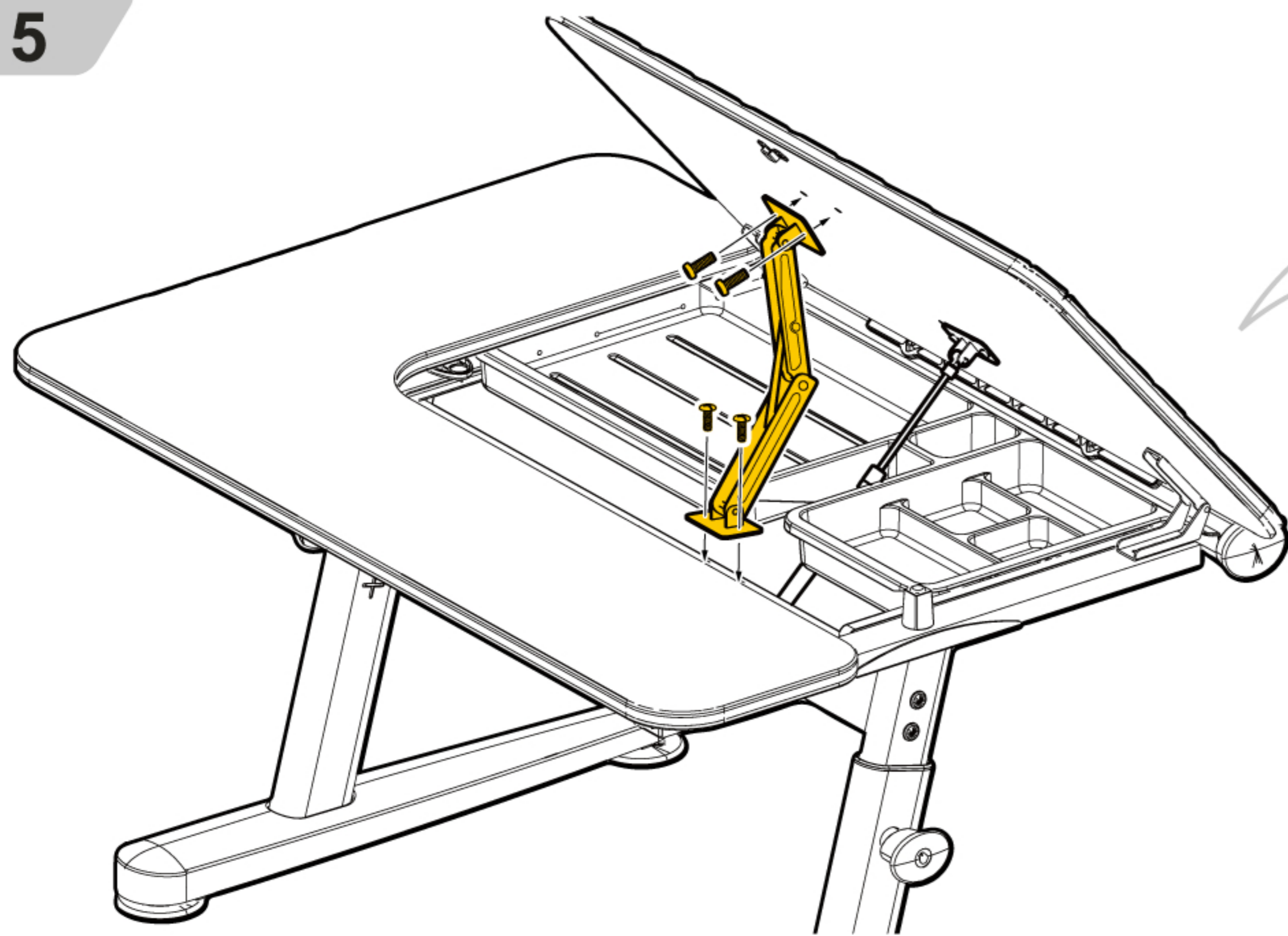

6

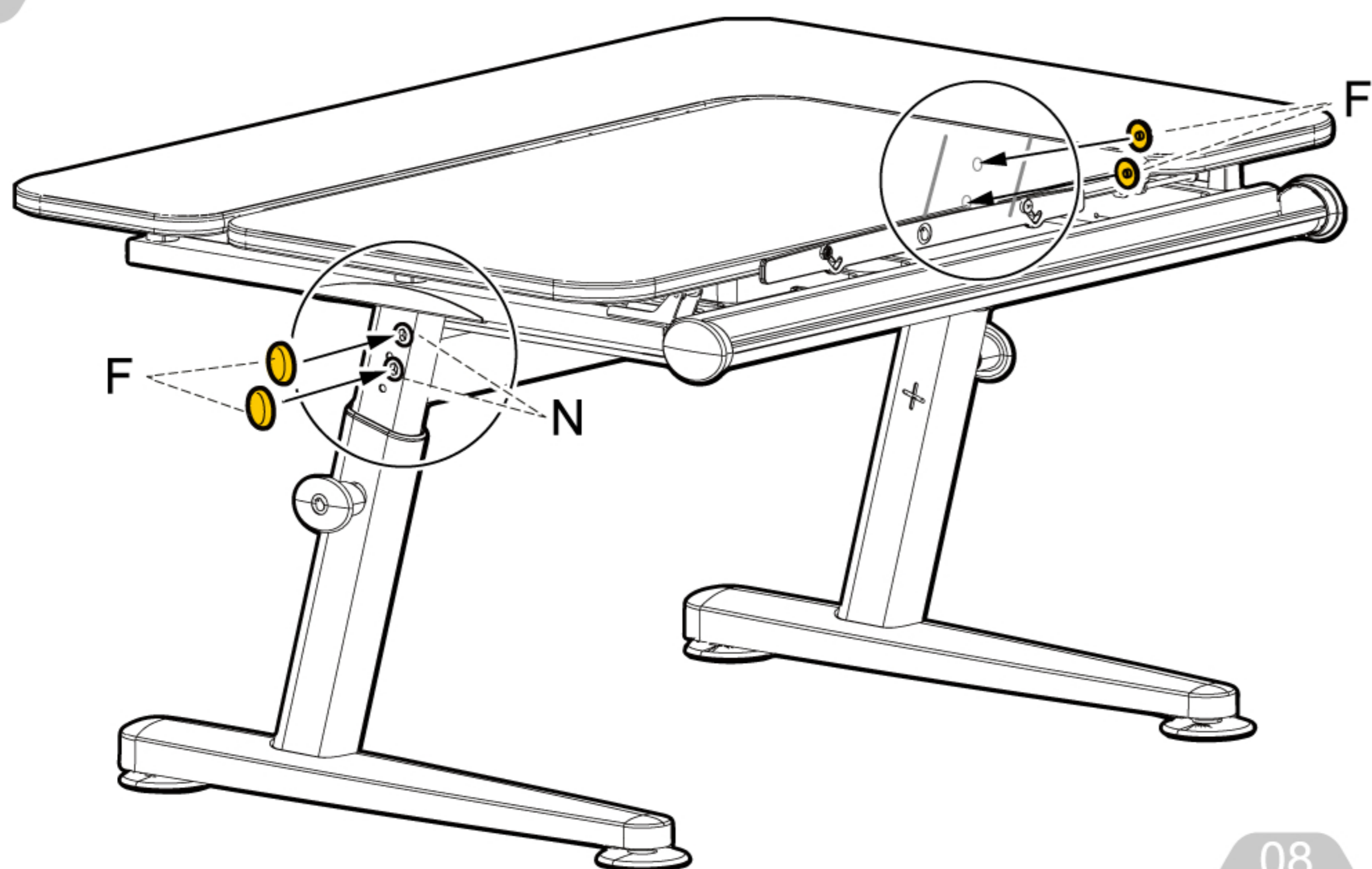

### Note

1. Ensure screws M of step 2 are fasten tightly.
2. Then fasten screws N tightly and covered with caps F of step 6.

Fasten screws tightly

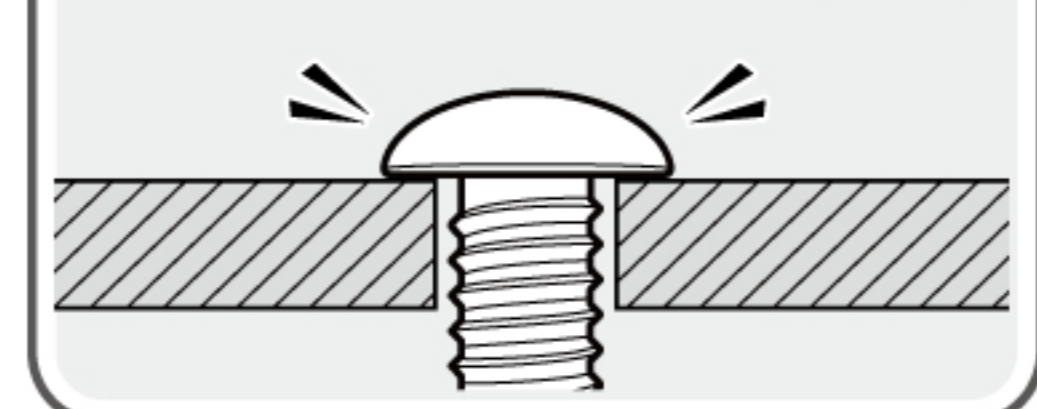



## Height adjustment

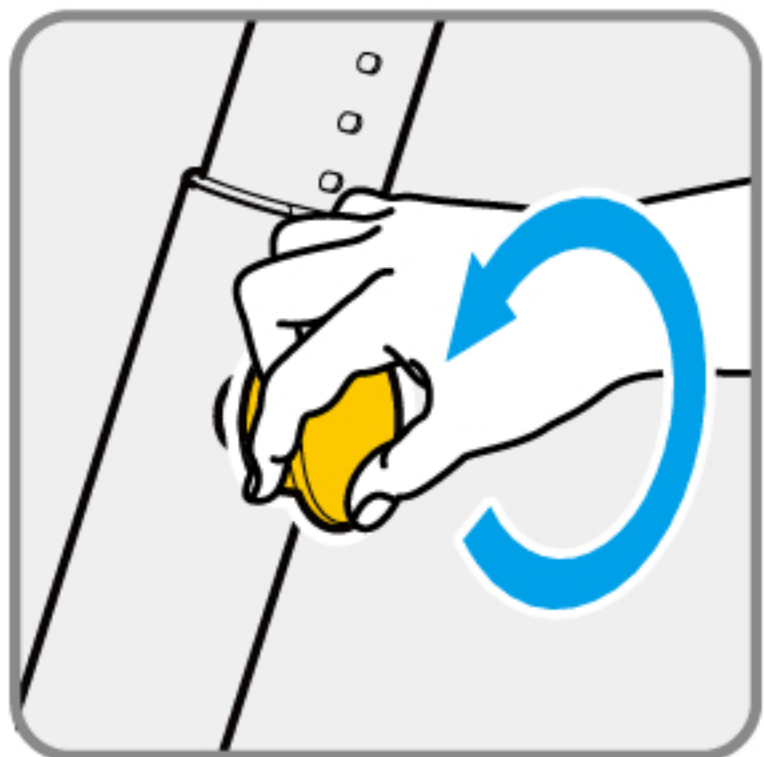

1. Counterclockwise to release the handle counterclockwise.

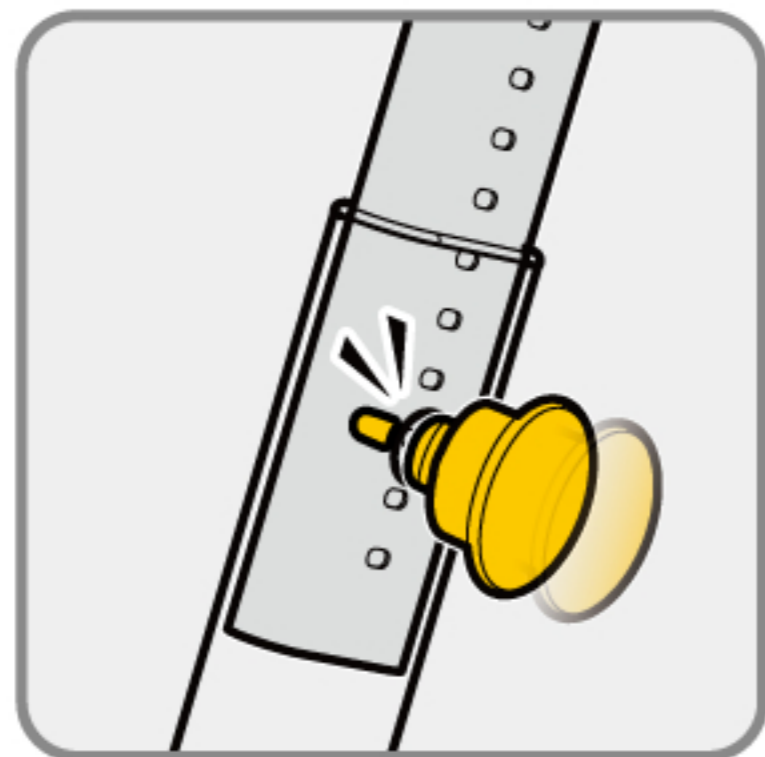

4. Be sure the pins into the holes after handle released.

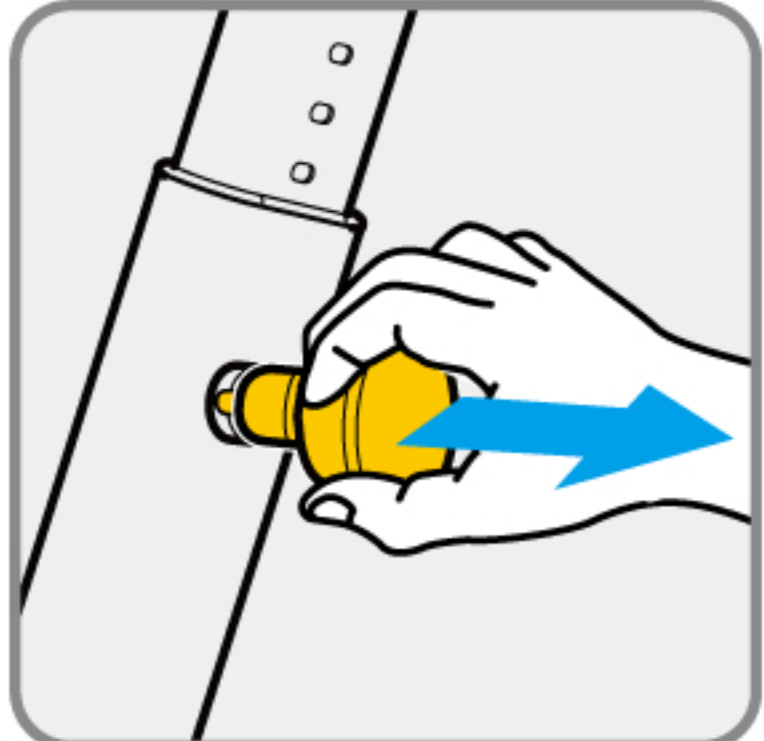

2. Pull the Handle out ward.



5. Lock the handle Clockwise.

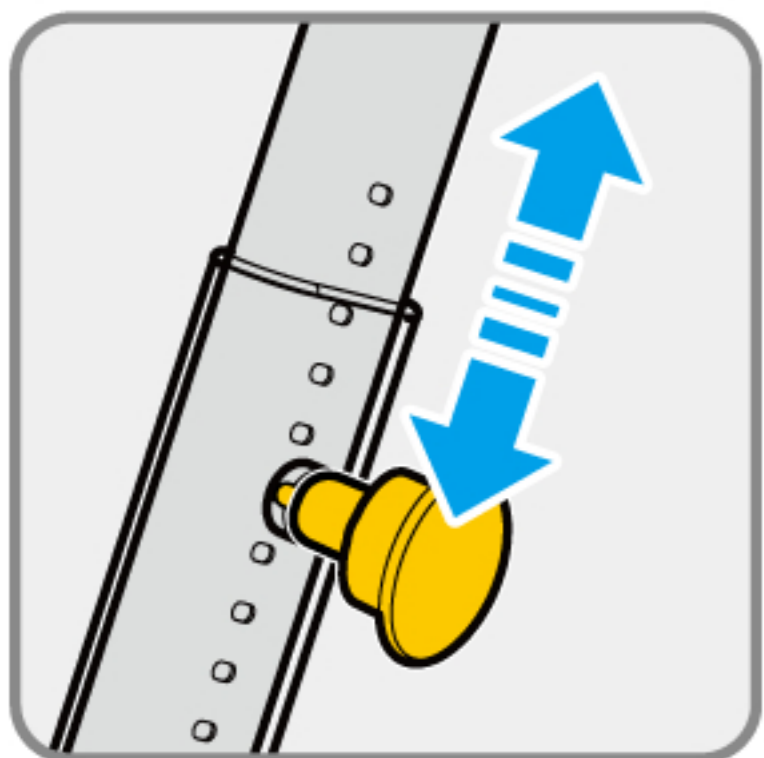

3. Adjust to wanted height.

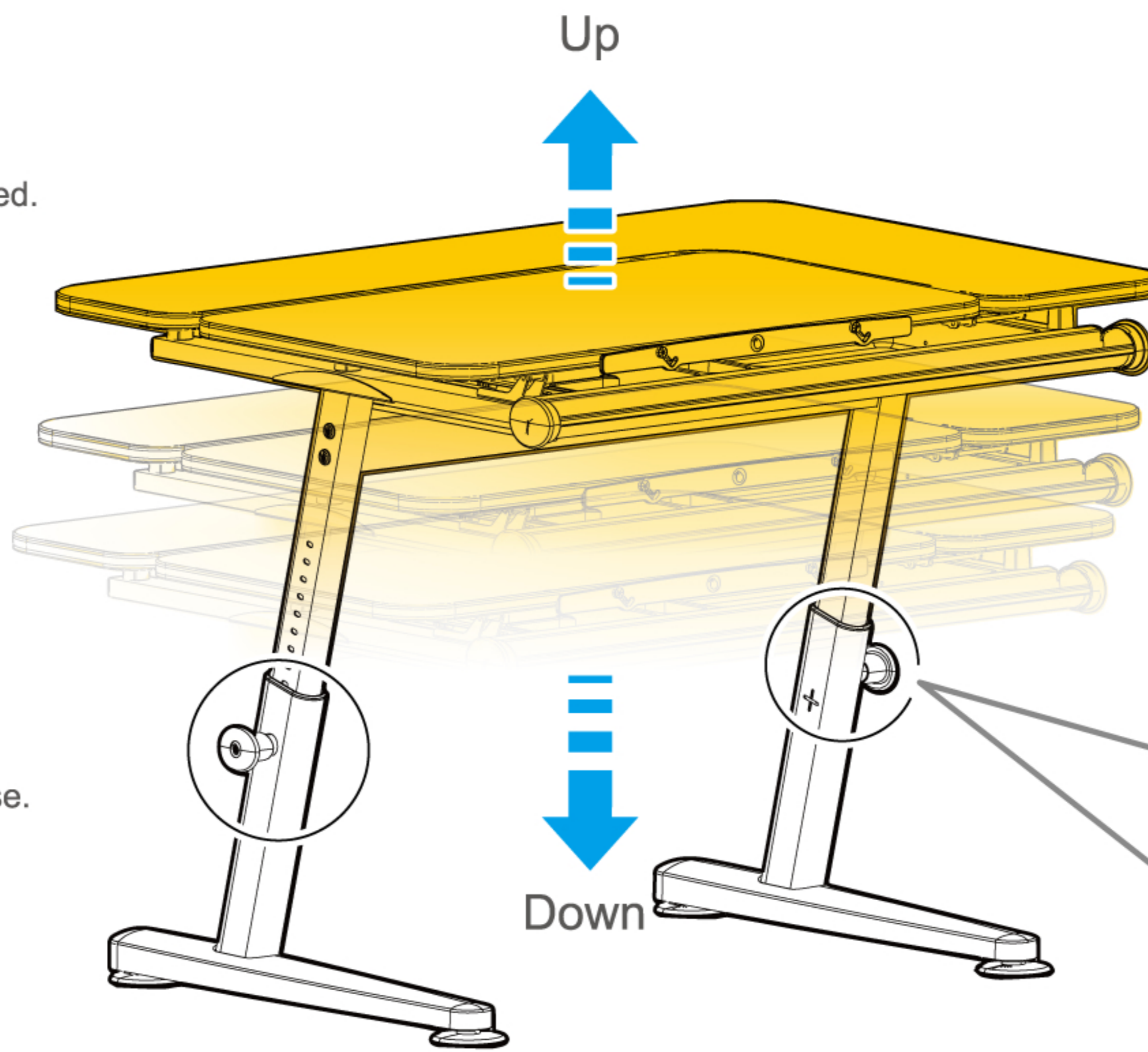



**Don't cross safety line.**

65	25 3/8"
67	26 3/8"
160 5' 3"	68 26 3/4"
70	27 1/8"
170 5' 7"	72 28 3/8"
<b>STOP</b>	

## Angle adjustment



1. Lift the top to ultimate.

2. Release hand, the top comes down automatically to horizon.

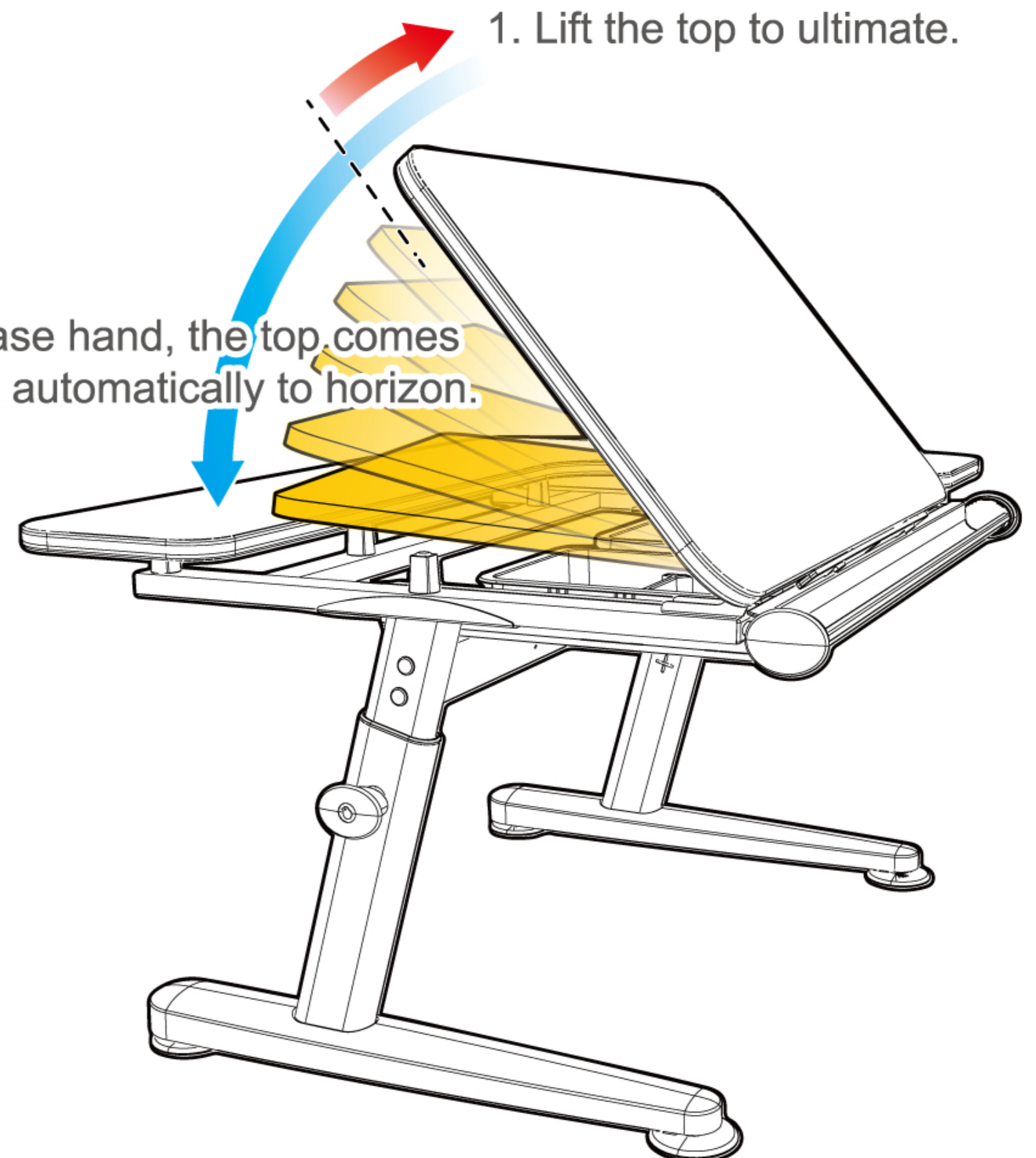



## A. What's 10+5+1 ?

10 years: STABILUS gas lift

5 years: Main structure such as metal frames, desktops

1 year: Other parts, such as casters, seat covers, accessories, school bags, lamps.

## B. Coverage of the warranty

1. This Warranty covers the defects resulting from defective parts, materials or manufacturing, if such defects are revealed during the warranty period since the date of purchase.
2. The device/ part is considered defective if it fails to perform the functions as indicated in the operation manuals and technical specifications, and the failure is due to internal characteristics.

## C. Terms of warranty

1. Local legal agents or dealers are responsible for the maintenance of Kid2Youth products.
2. Papers to prove the ownership and the exact purchasing date as well as a detailed and readable description or photos of the technical problem must be presented.
3. If the defect is verified as covered by the warranty, the Kid2Youth local agent or dealer will confirm back the repairing service time and replacement items.
4. If the defect is not covered by the warranty, the Kid2Youth local agent or dealer will inform the cost of repairing. All expenses of repairing materials, labors and transportation shall be covered by the customer.
5. All products should be repaired by the Kid2Youth local agent or dealer to keep the warranty valid.
6. The ownership of the defect parts or products shall be transferred to Kid2Youth after the repairing.
7. If Kid2Youth no longer sells the defective merchandise, suitable alternative merchandise shall be offered for the replacement.
8. Kid2Youth reserves the rights of amending the warranty policy.

## D. Warranty exceptions

1. Natural loss such as collision, cutting, or improper human operator.
2. The merchandise placed in outdoor or moist environment.
3. Mechanical damages resulting from incorrect installation, configuration, usage or other activities inconsistent with the operation manual.
4. The merchandise that has been tempered with by the warranty beneficiary or any other people in any way, including reconfiguration, repair, willful constructional variations, modifications and adjustments.
5. Damages caused by acts of natural disasters such as floods, fires, lighting and wars, unexpected events, inappropriate voltage or other external factors.
6. The surface color changed due to the time duration of more than a year.
7. Exhibits or products purchased from auctions, trade fairs, and special- discount deals.
8. Quality assurance covers only the original purchaser. The rights and interests are not transferable.
9. Unable to present papers to prove the ownership and the exact purchasing date.

## E. Trouble shooting and reminder

1. Study the operation manual and assembly instruction before operating the product.
2. Do not disassemble the product structure, or the rights of quality assurance services shall be affected.
3. Periodically check all connection components and apply lubrication if needed.
4. Adjust the desktop height occasionally to keep the gas lift operate smoothly.
5. Make sure all screws are properly fixed few weeks after the installation.
6. If bags' zippers are stuck, gently pulling it back and forth for few times may solve the issue.
7. Using corrosive detergent to clean the surface is strictly forbidden. Better to use warm water under 40° (104° Fahrenheit) Celsius with soft cleaning agent and wipe dry the surface after cleaning.





주의사항

- 4세 이상 사용
- 성인에 의해 조립
- 아이가 사용 시 어른이 함께 하십시오.



1 상판

M2+ | XXS

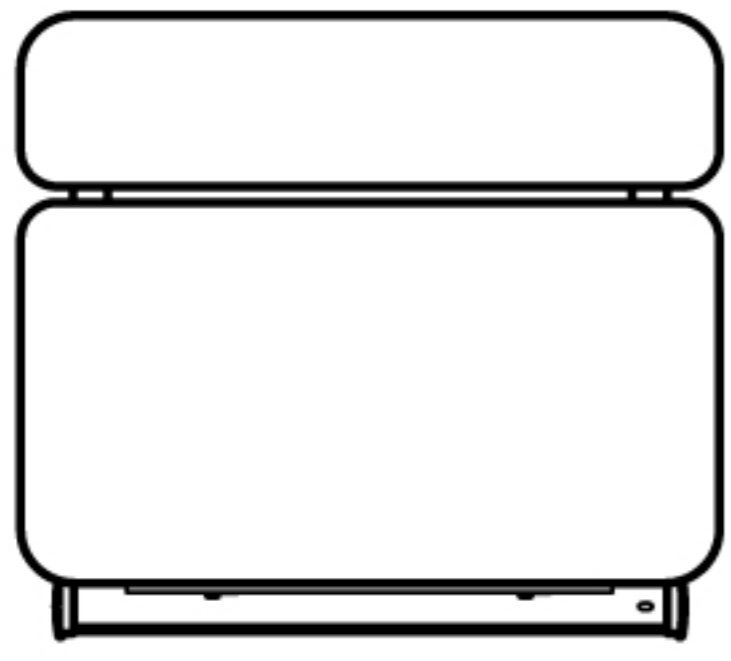

M6+ | XS  
S

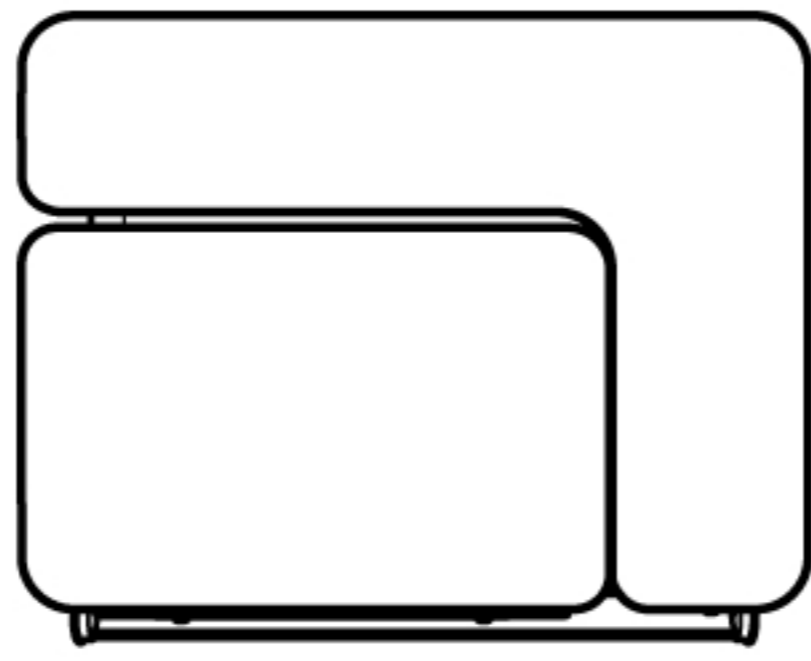

Parts Kit

M 육각나사 X 4

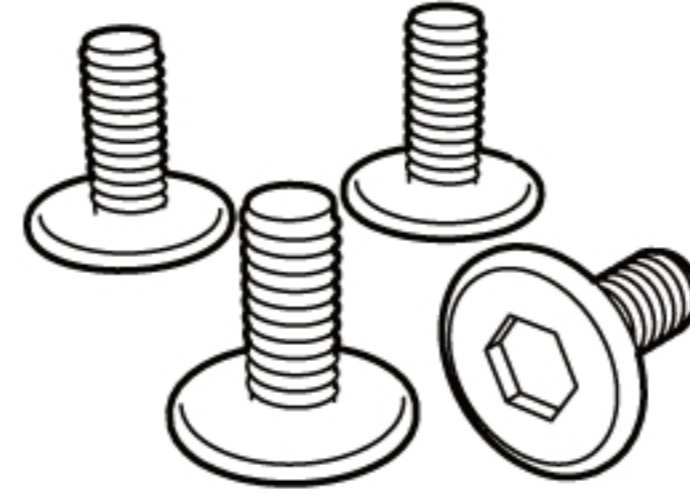

M6\*12mm

N 육각나사 X 4

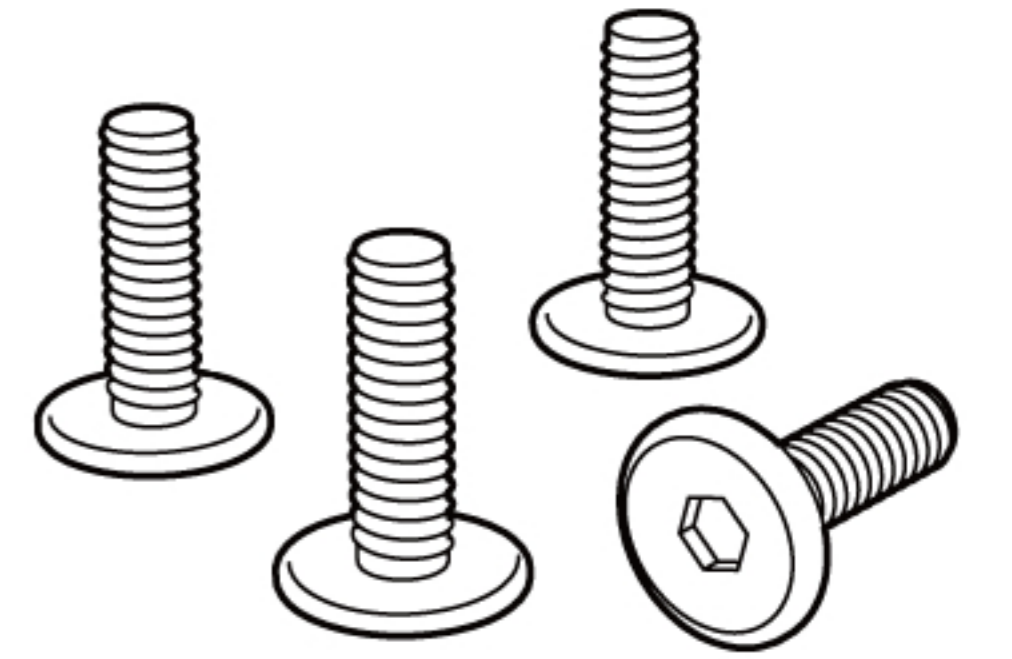

M6\*19mm

F 캡 X 4

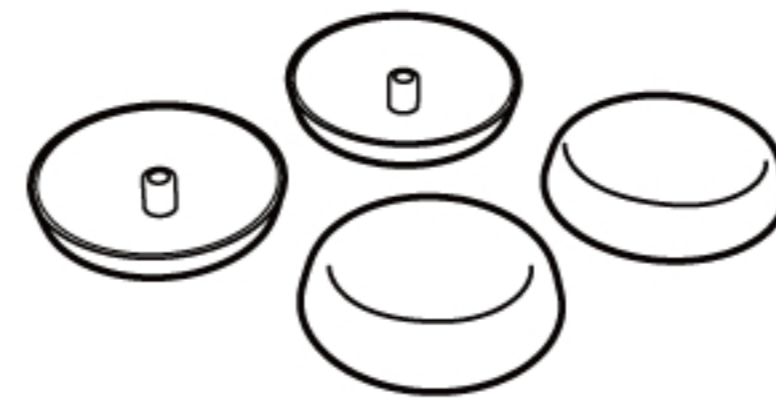

육각키 렌치



NO.4

2 다리

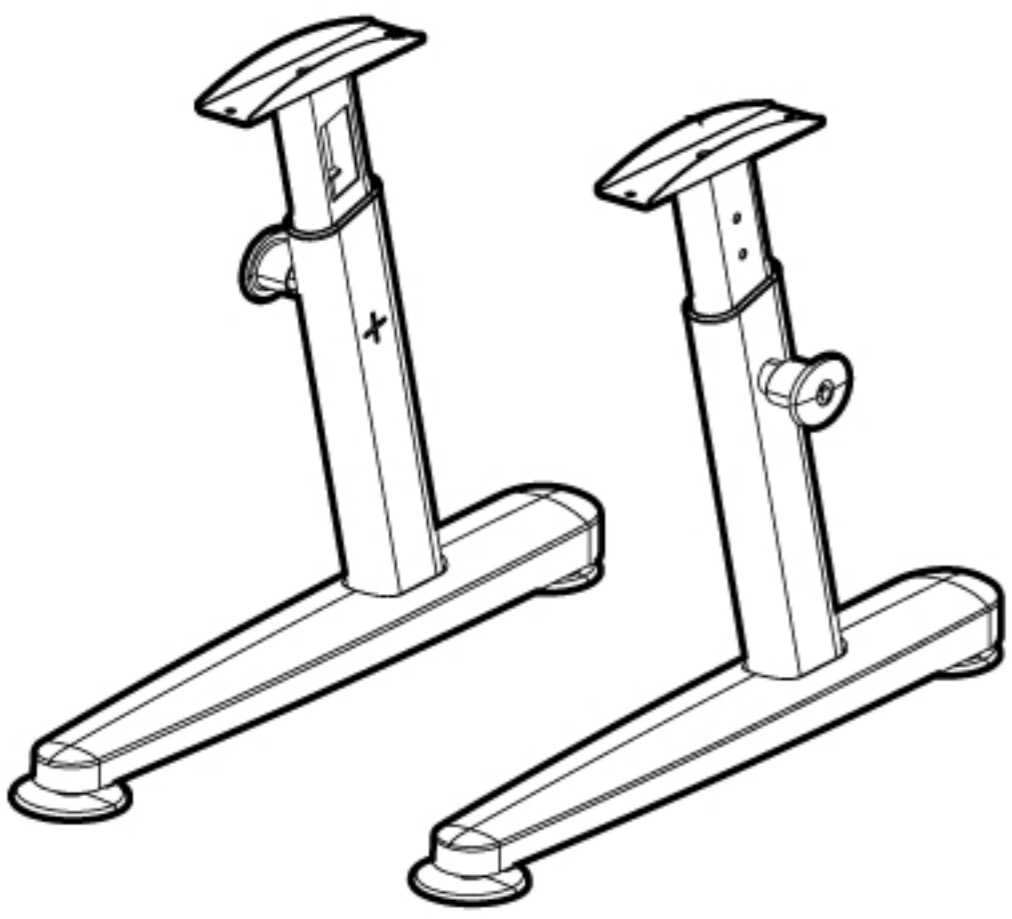

3 중간 수평 샤프트

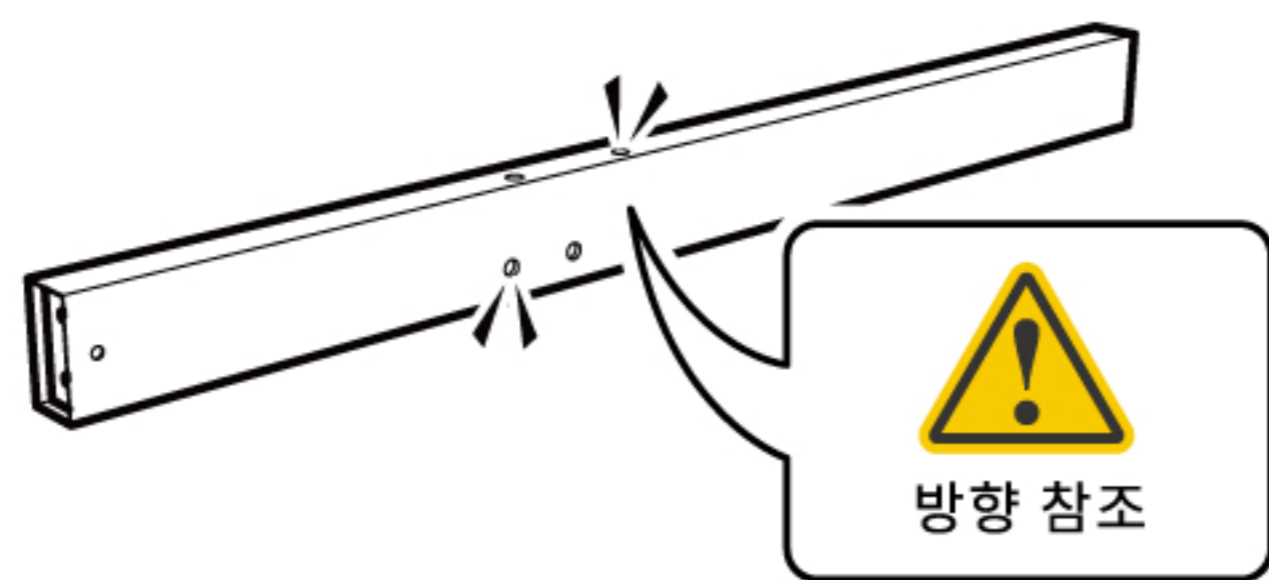

4 경사 각도 바

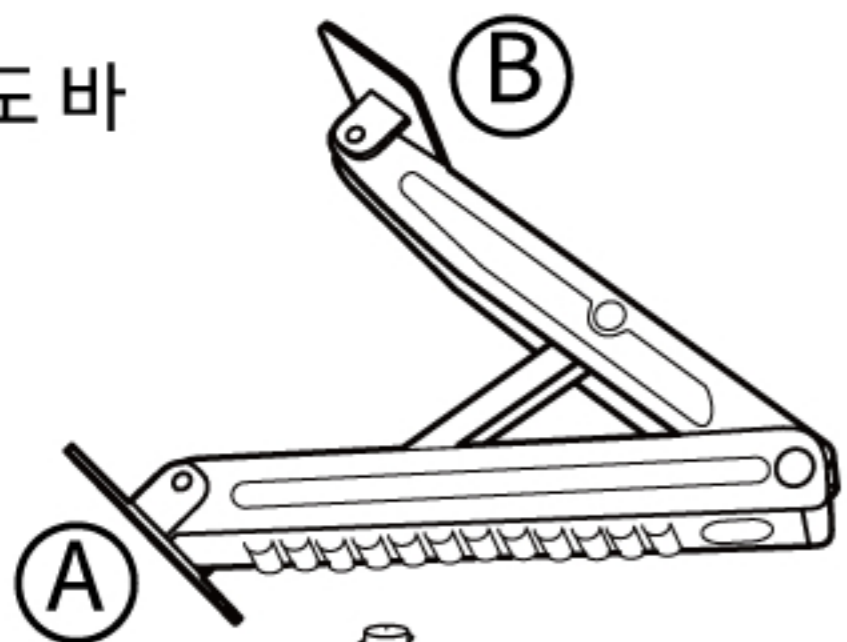

4-H나사  
4.8\*14mm

4-E나사  
M4\*12mm

5 오일 버퍼

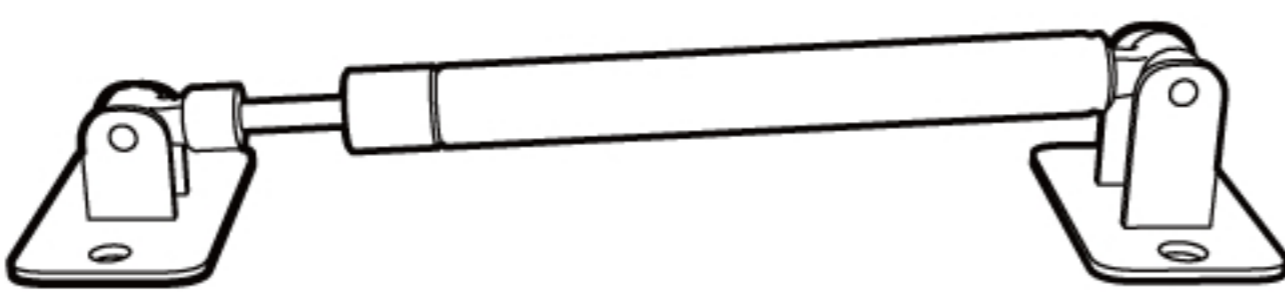

5-H나사  
4.8\*14mm

5-E나사  
M4\*12mm

1

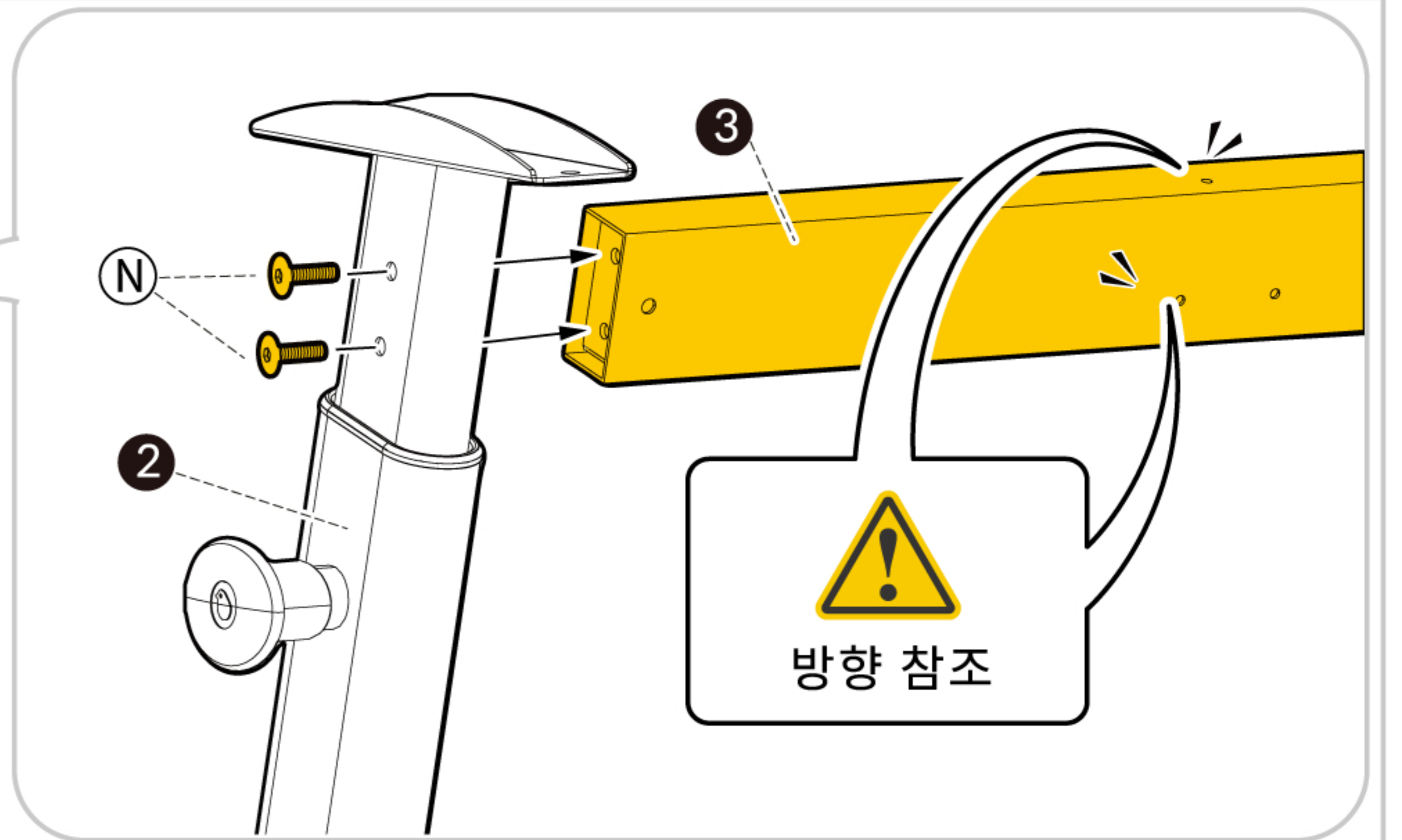
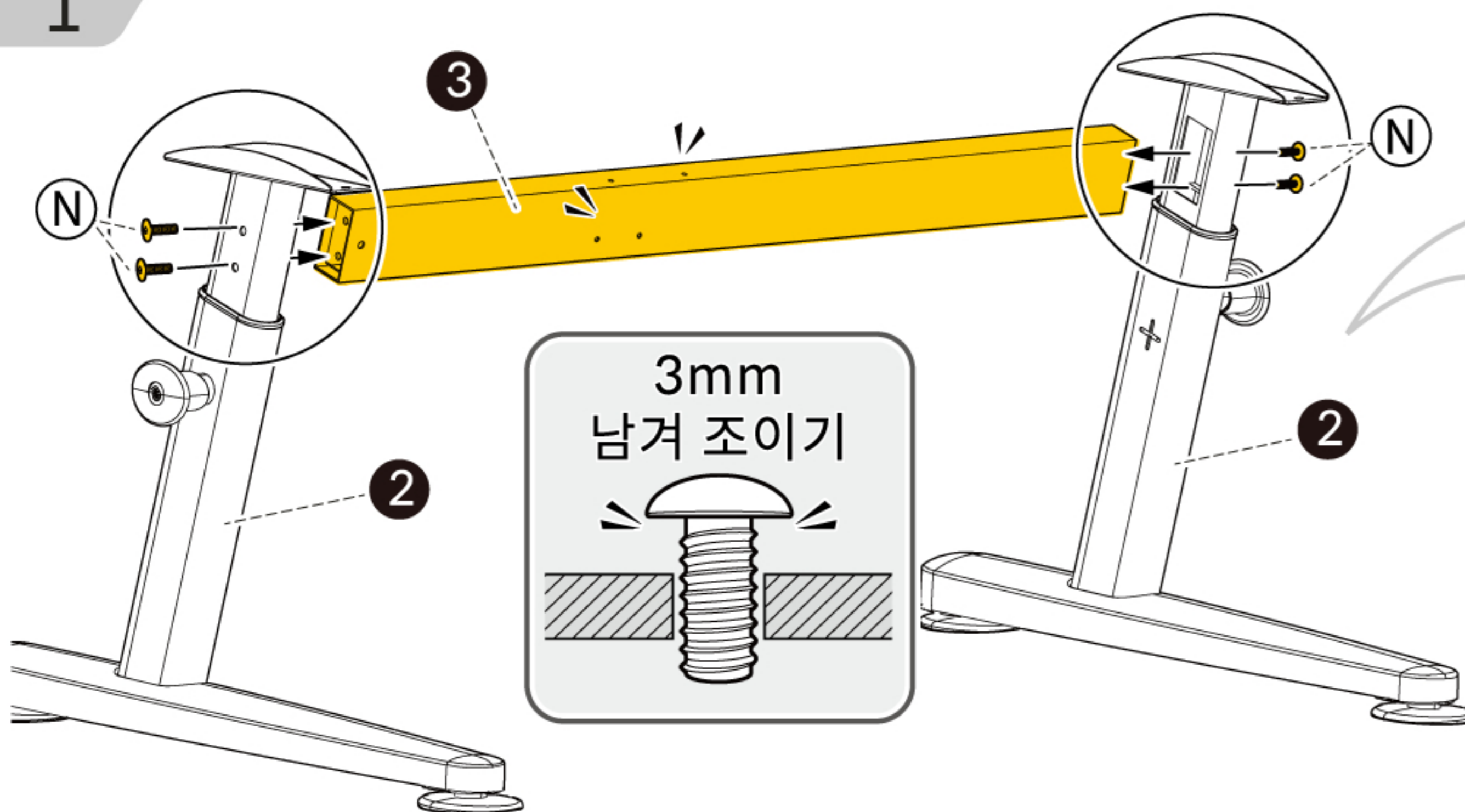

2

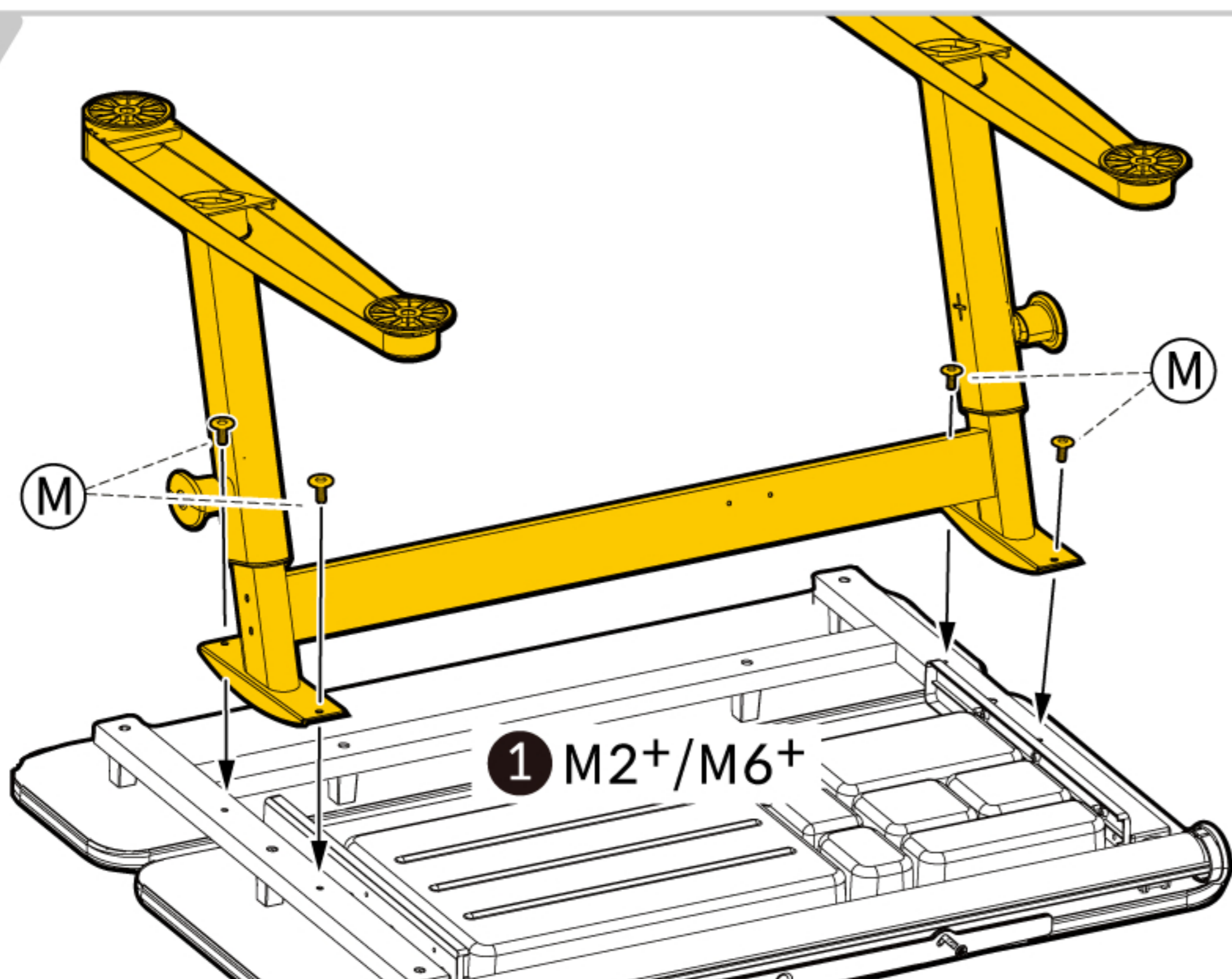

Note

Step 1. 왼쪽, 오른쪽 다리가 서로 대칭 되도록 설치 하십시오.

Step 2. 책상 다리와 중간 수평 샤프트가 서로 수직이 되도록 설치 하십시오.

Step 3. N 나사를 조이십시오

나사를 단단히 조이기

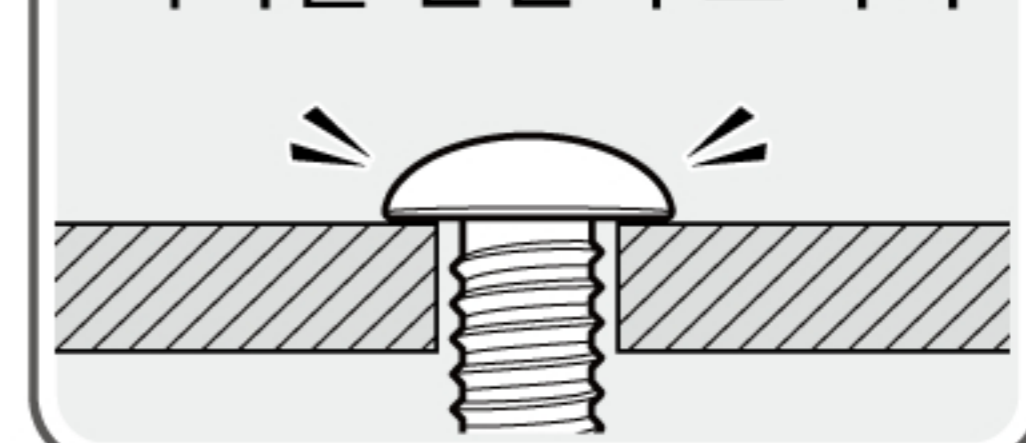



3

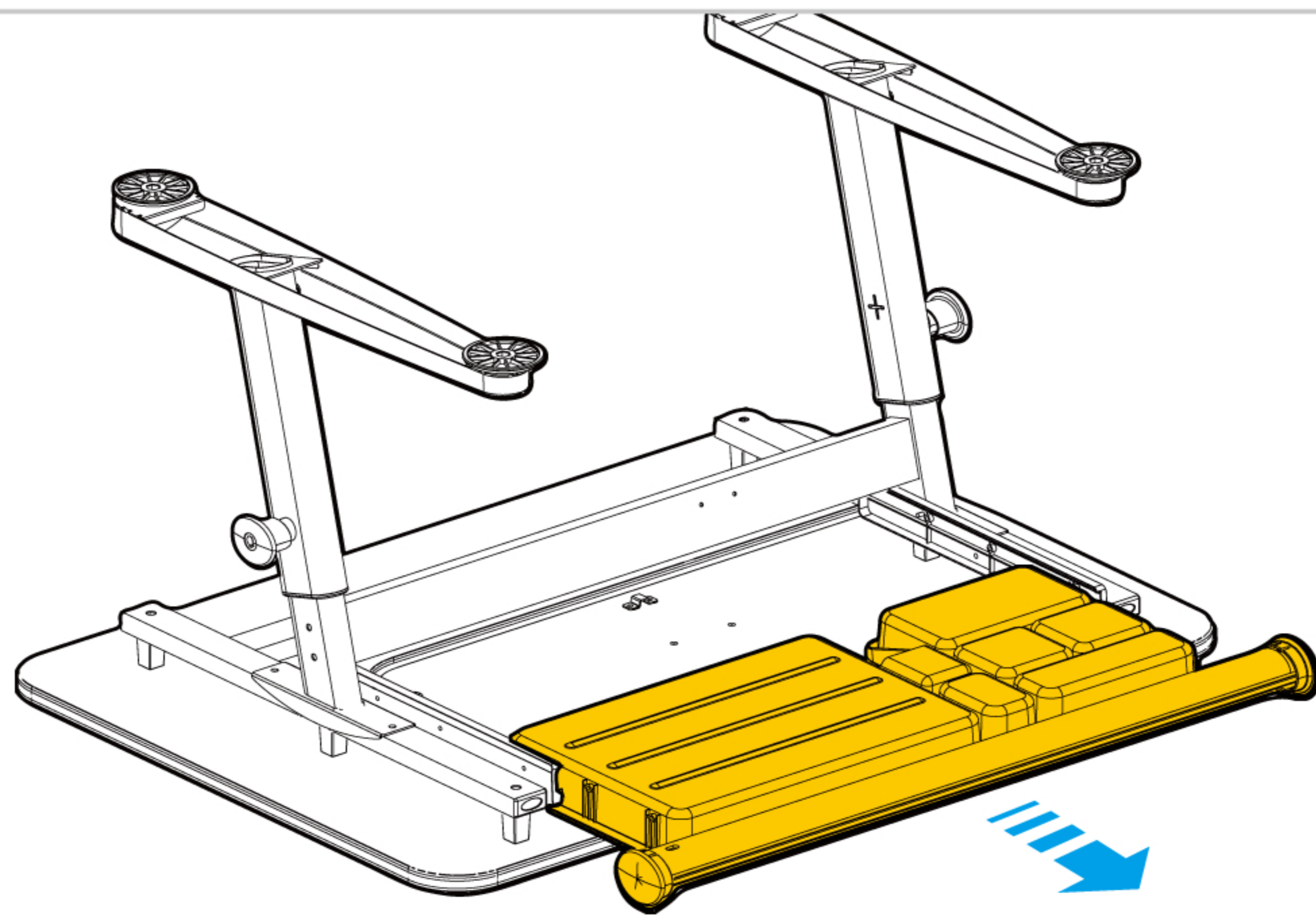

4

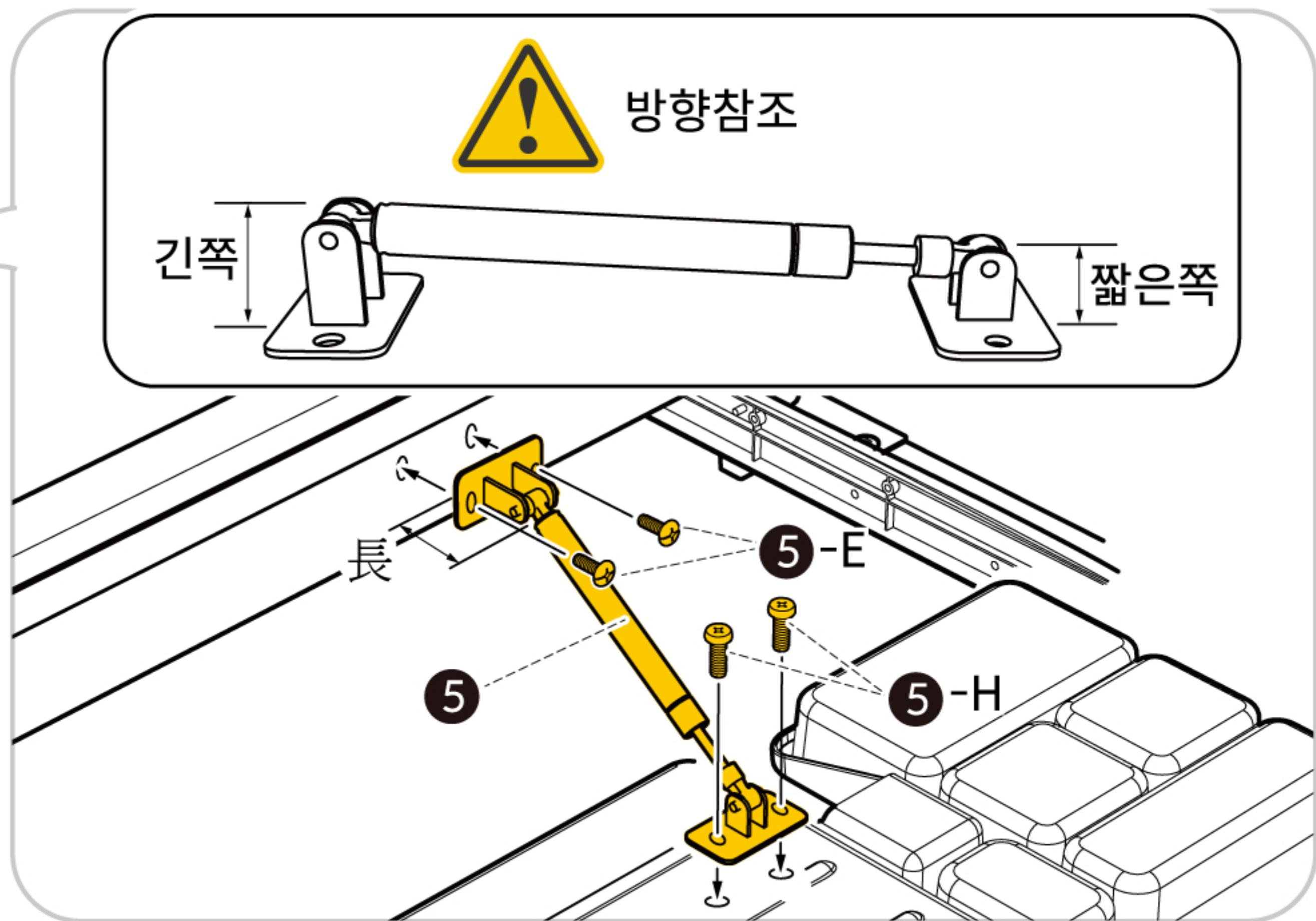
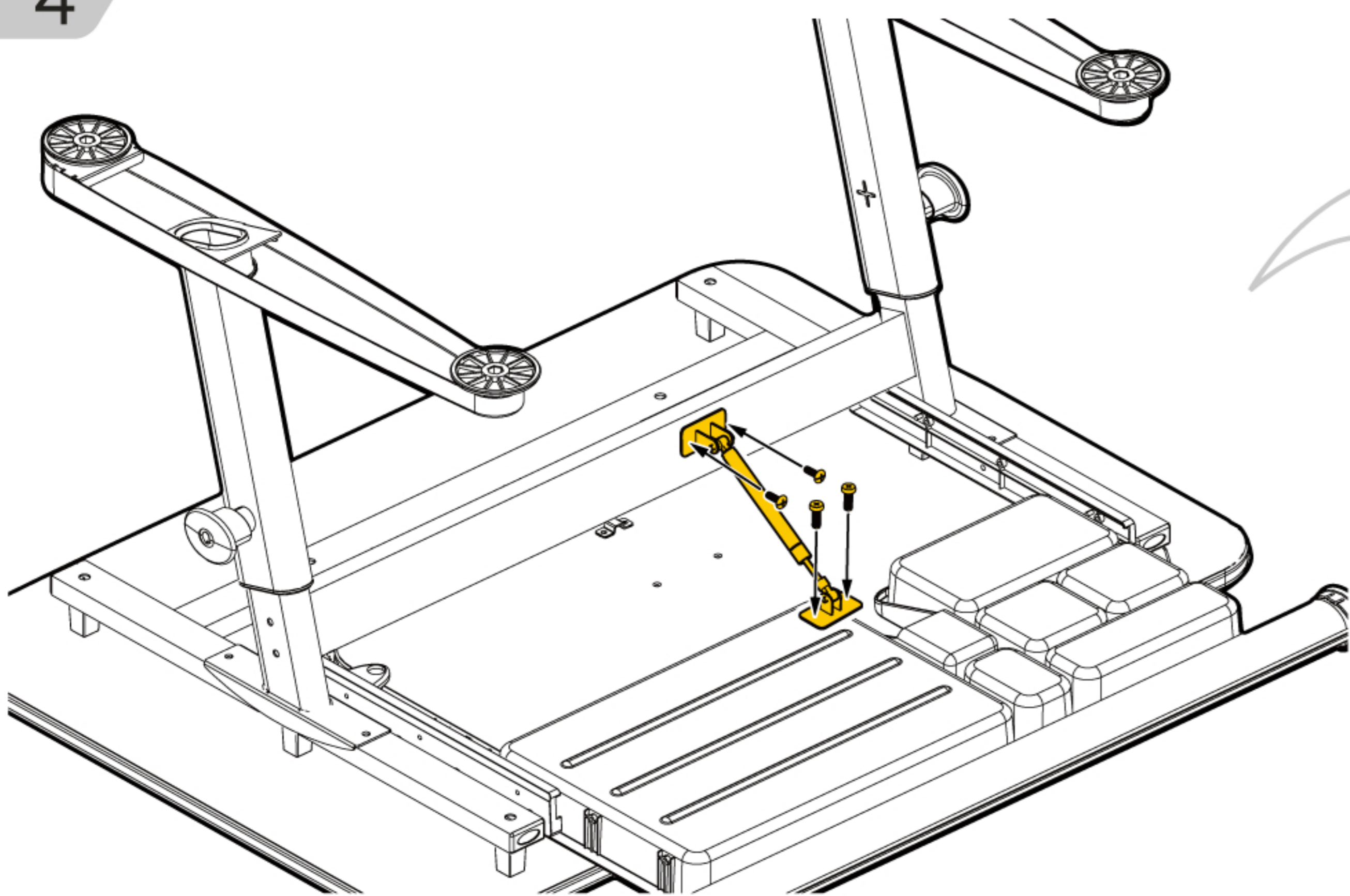

5

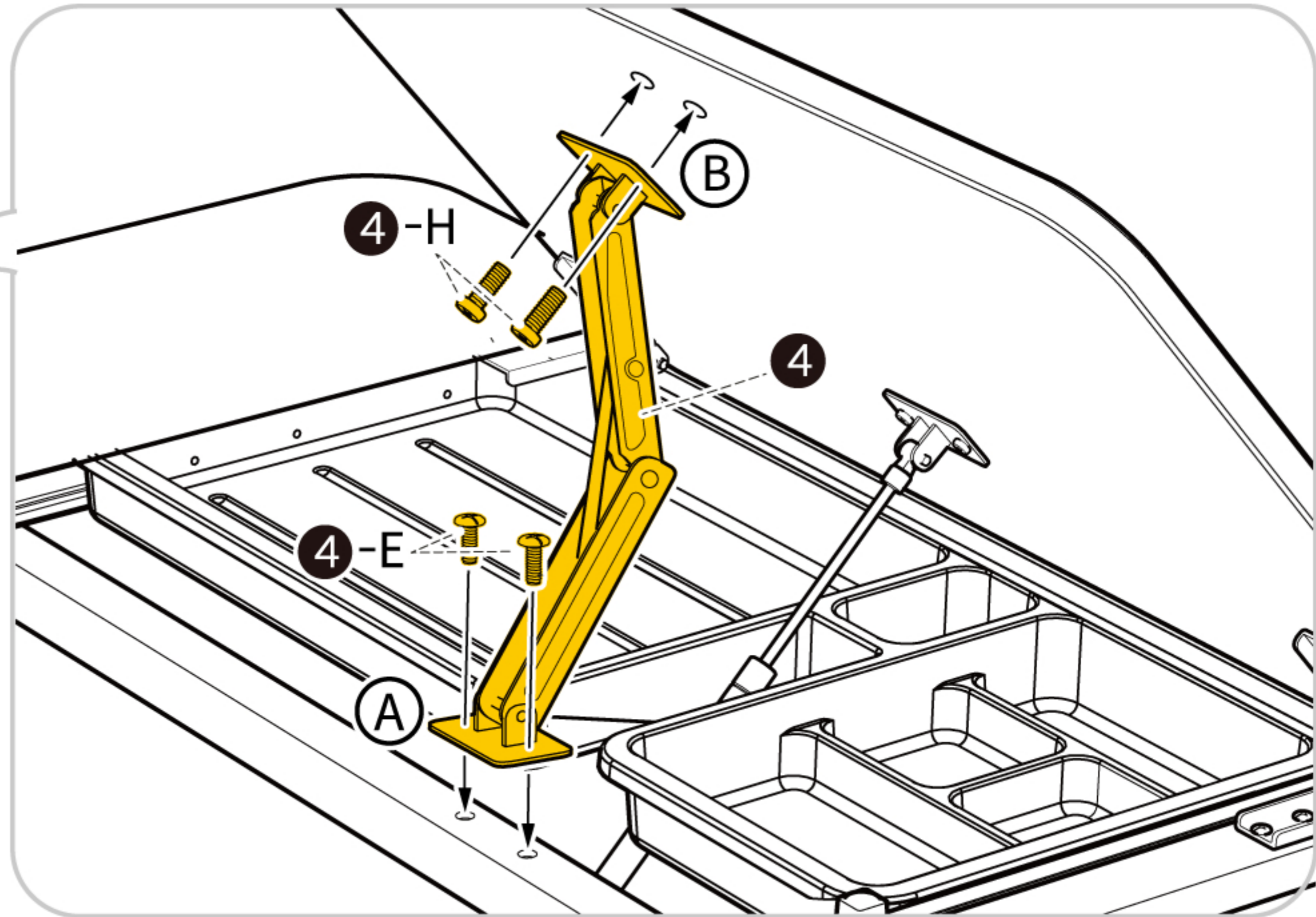
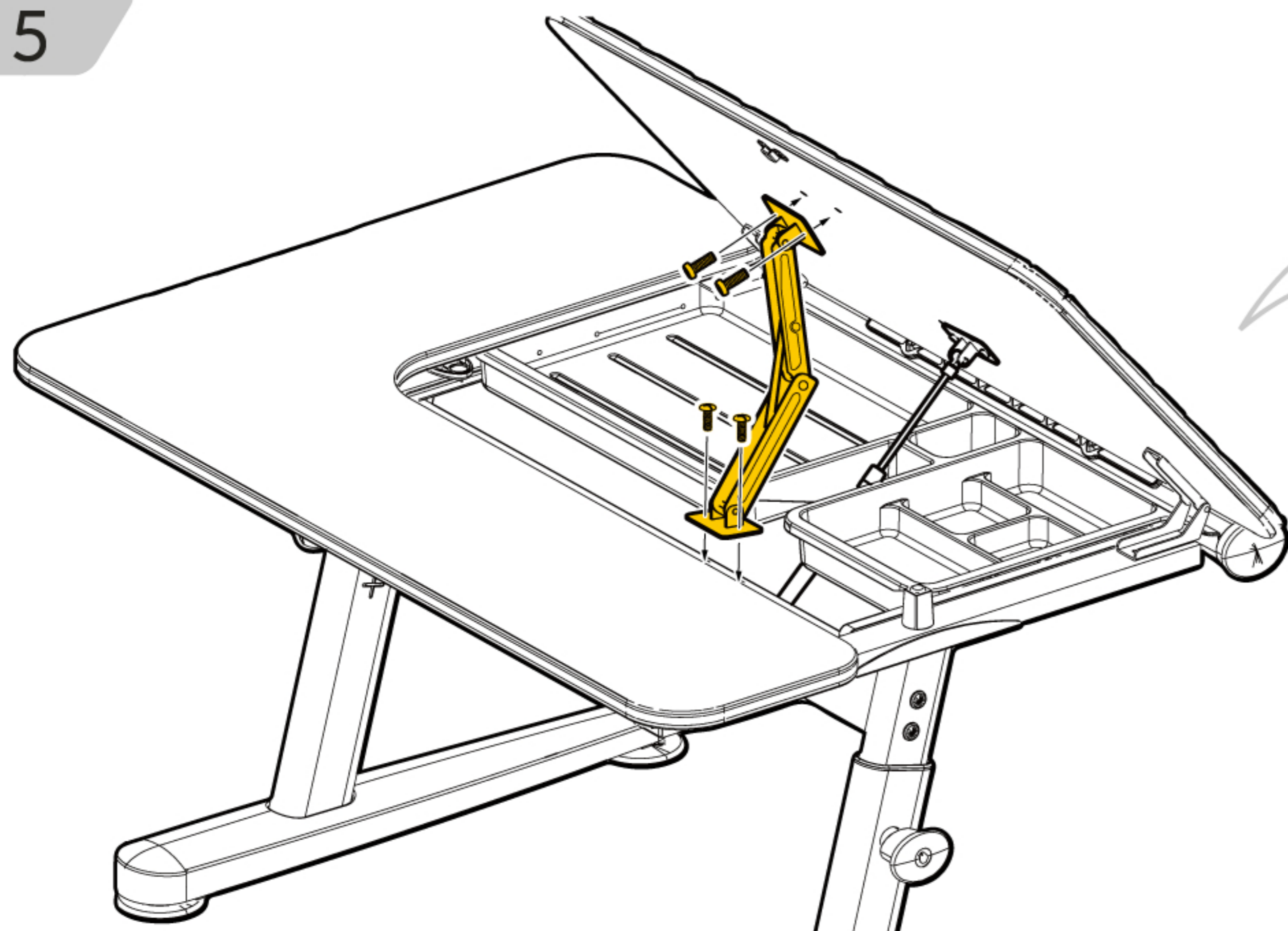

6

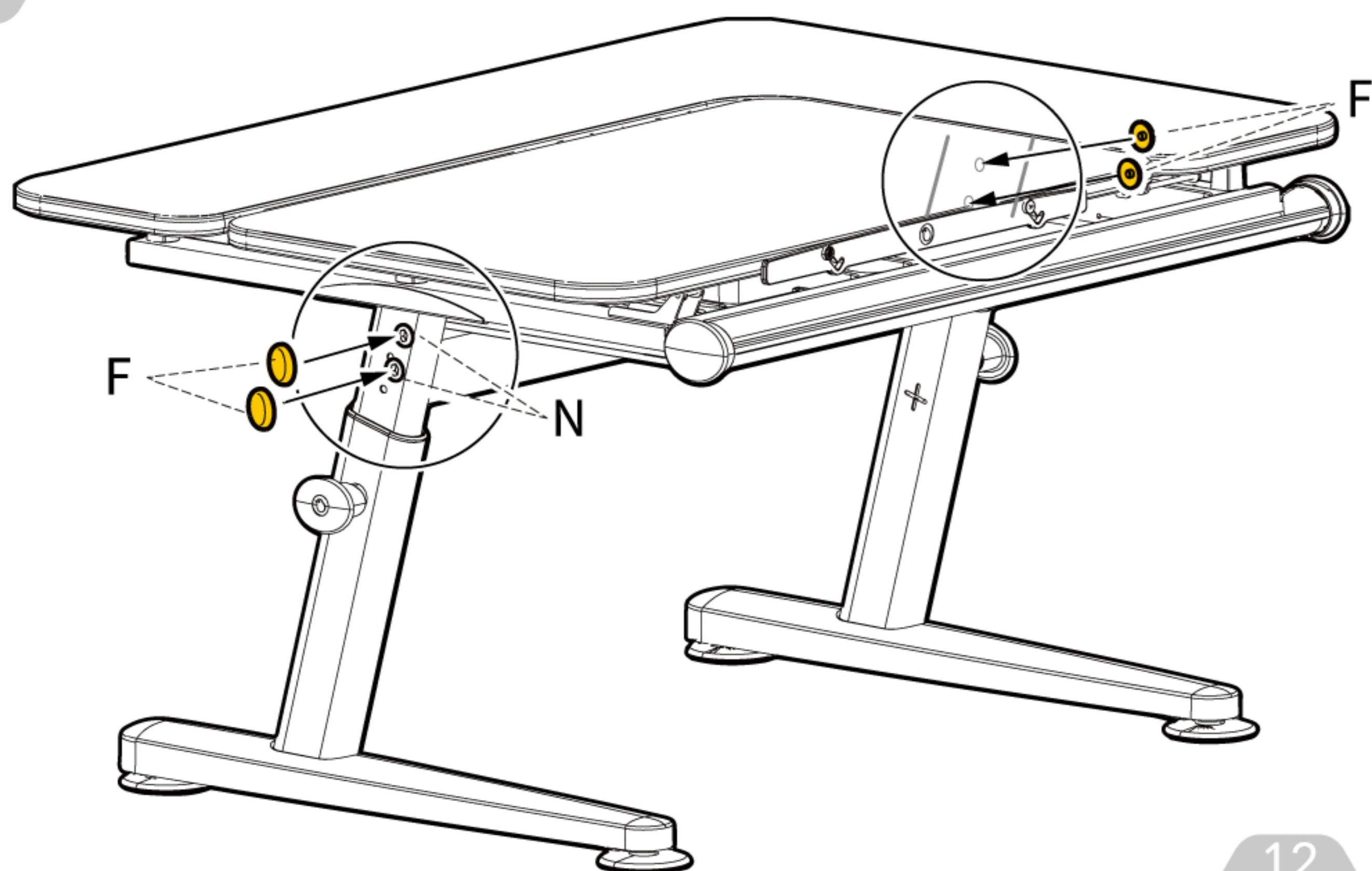

Note

1. 2번째 단계에서 M나사를 단단히 조였는지 확인하십시오.
2. N나사를 단단히 조이고 F캡을 끼웁니다.





높낮이 조절

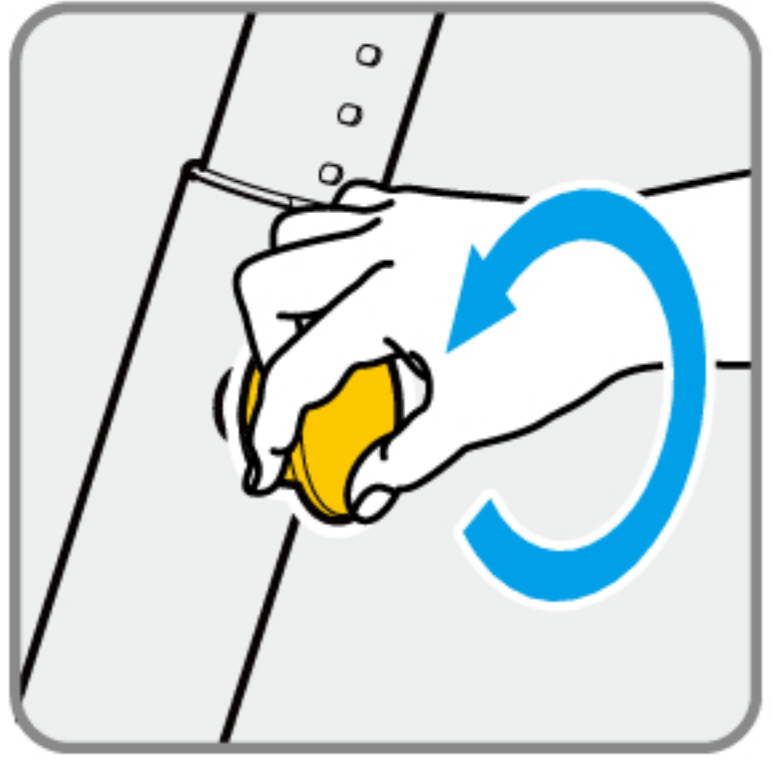

1. 시계 반대 방향으로 핸들을 돌려주세요.

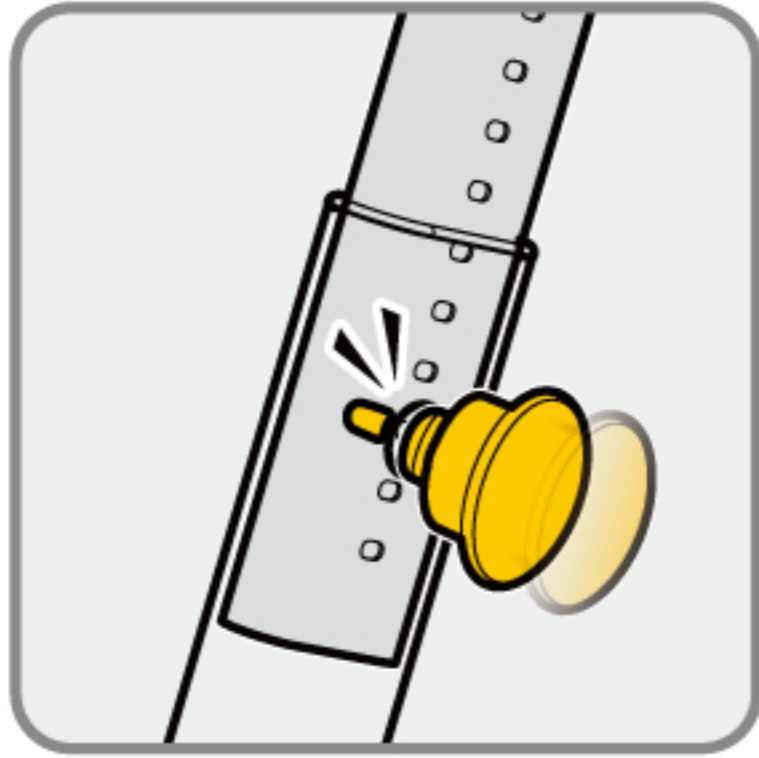

4. 핀이 구멍안으로 들어간 것을 확인하세요.

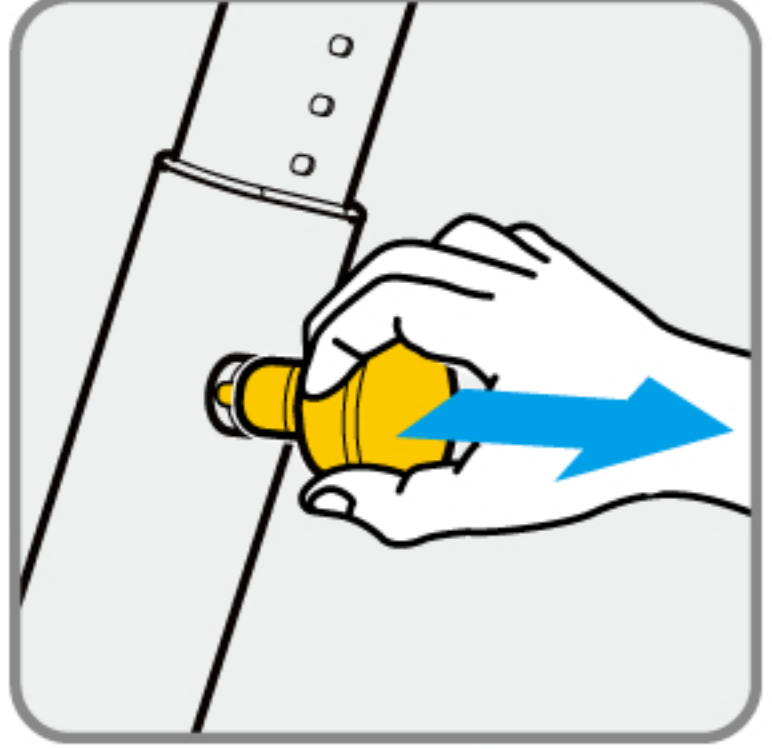

2. 핸들을 당겨주세요.



5. 시계방향으로 핸들을 돌려 고정합니다.

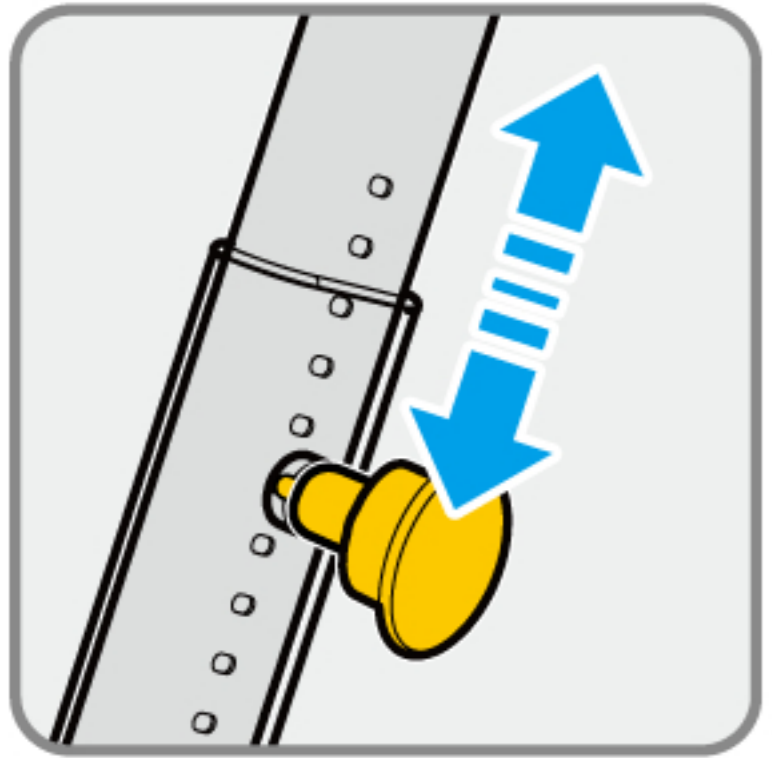

3. 원하는 높이로 조절하세요.

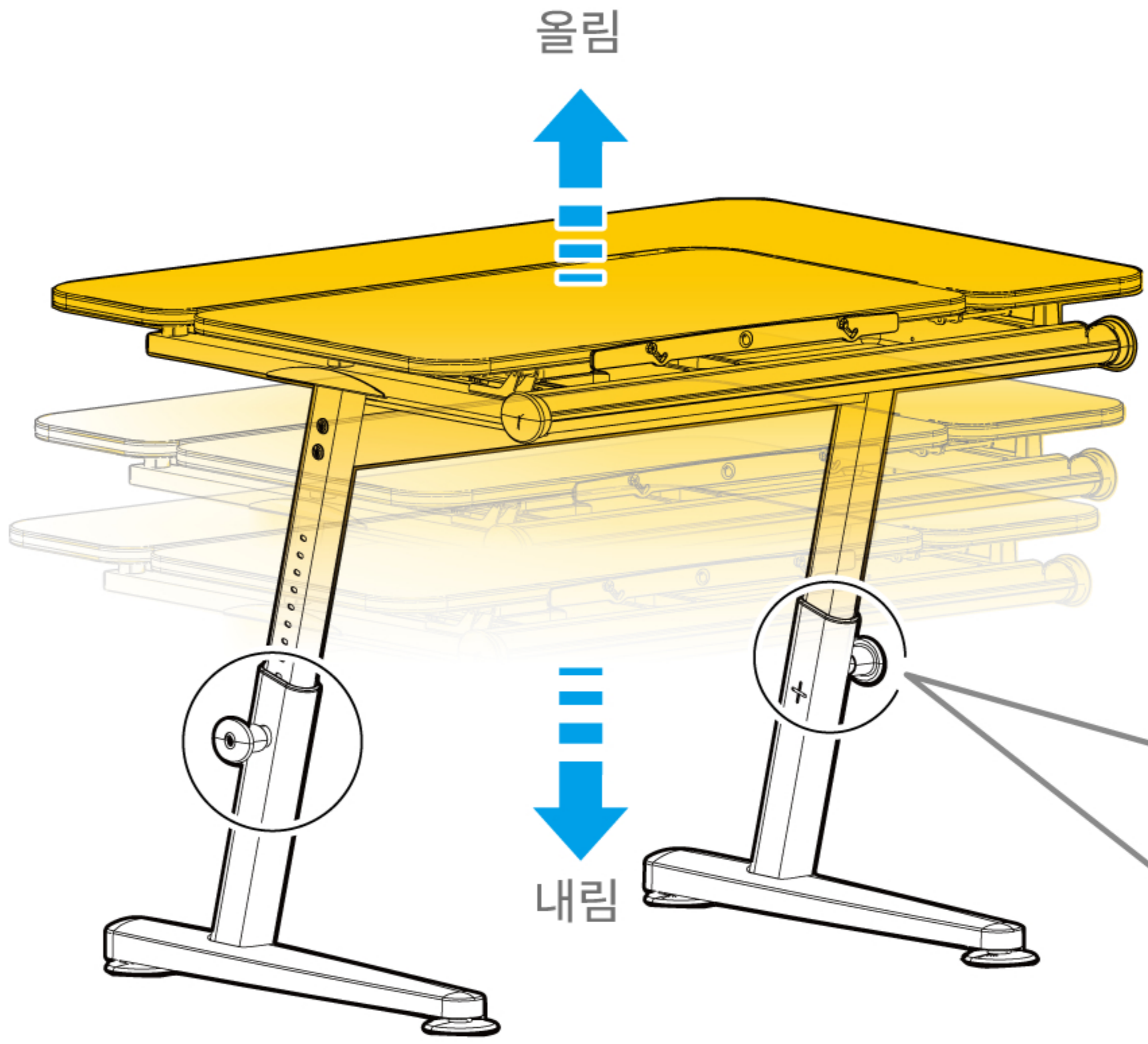

안전선을 넘지 마세요.

65	25 1/8"
67	26 3/8"
160	5' 3"
68	26 3/4"
70	27"
170	5' 7"
STOP	72
	28 3/8"

각도 조절

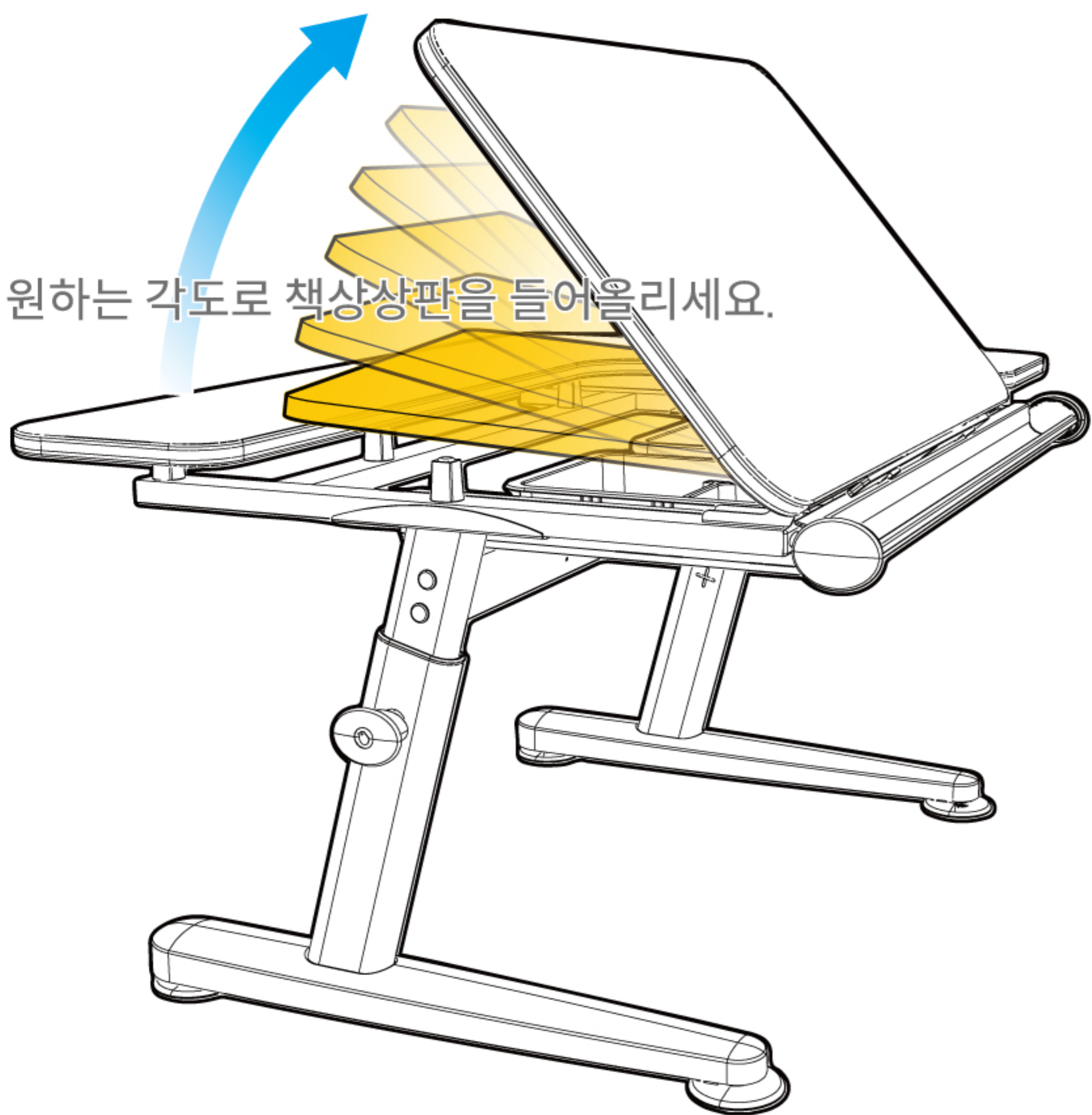

원하는 각도로 책상상판을 들어올리세요.



1. 책상 상판 각도를 최대로 올림.

2. 최대 각도를 넘기면 고정이 풀리면서 최소 각도로 되돌아옵니다.



## A. 10+5+1 이란 무엇입니까 ?

10년 : 안정된 가스 리프트

5년 : 금속 프레임, 데스크탑 등의 주요 구조

1년 : 바퀴, 시트 커버, 액세서리, 학교 가방, 램프와 같은 기타 부품.

## B. 보증 범위

1. 본 보증서는 구입일로부터 보증 기간 동안 발견된 부품, 재료 또는 제조상의 결함에 대해 보증합니다.
2. 사용 설명서 및 기술 사양에 명시된 기능을 수행하지 못하고 내부 특성으로 인한 고장인 경우 장치 / 부품이 불량으로 간주됩니다.

## C. 보증 및 서비스

1. 현지 법률 대리인 또는 공식수입사는 Kid2Youth 제품의 유지 관리를 책임집니다.
2. 소유권과 정확한 구매 날짜를 증명하는 문서와 기술 문제에 대한 상세하고 읽을 수 있는 설명 또는 사진을 제시해야 합니다.
3. 보증이 적용되는 것으로 결함이 확인되면 Kid2Youth 공식수입사 및 대리인이 수리 서비스 시간 및 교체 품목을 다시 확인합니다.
4. 결함이 보증 범위에 포함되지 않는 경우, Kid2Youth 공식수입사 및 대리인이 수리 비용을 알려 드릴 것입니다.  
수리, 인건비 및 운송비는 고객 부담입니다.
5. 모든 제품은 보증을 유지하기 위해 Kid2Youth 공식수입사 및 대리인에 의해 수리되어야 합니다.
6. 결함이 있는 부품 또는 제품의 소유권은 수리 후 Kid2Youth에 양도됩니다.
7. Kid2Youth가 결함이 있는 상품을 더 이상 판매하지 않을 경우, 적절한 대체 상품이 교체를 위해 제공됩니다.
8. Kid2Youth는 보증 정책을 수정할 권리가 있습니다.

## D. 보증에서 제외되는 경우

1. 충돌, 절단 또는 부적절한 작업자의 자체 수리로 인한 제품의 손상은 보장하지 않습니다.
2. 실외 또는 습한 환경에 노출되었던 제품의 손상은 보장하지 않습니다.
3. 잘못된 설치, 구성, 사용 또는 작동 설명서와 일치하지 않는 기타 활동으로 인한 기계적 손상은 보장하지 않습니다.
4. 구매자 또는 다른 사람이 재구성, 수리, 고의적인 구조적 변형, 수정 및 조정을 한 제품은 보장하지 않습니다.
5. 홍수, 화재, 낙뢰, 전쟁, 예상치 못한 사건, 부적절한 전압 또는 기타 외부 요인과 같은 천재 지변 행위로 인한 손상된 제품은 보장하지 않습니다.
6. 1년 이상의 시간으로 인해 표면 색상이 변한 제품은 보장하지 않습니다.
7. 경매, 무역 박람회 및 특별 할인 거래에서 구매한 전시품 또는 제품에 대해서는 적용되지 않습니다.
8. 품질 보증은 원래 구매자에게만 적용됩니다. 권리와 이익은 다른 이에게 양도 할 수 없습니다.
9. 소유권 및 정확한 구매 날짜를 증명하는 서류를 제시 할 수 없는 경우는 적용되지 않습니다.

## E. 유지 보수 안내서

1. 제품을 사용하기 전에 사용 설명서 및 조립 지침을 숙지하십시오.
2. 임의로 제품 구조를 분해하지 마십시오. 품질 보증 서비스의 권리에 영향을 미칩니다.
3. 모든 연결 구성 요소를 주기적으로 확인하고 필요한 경우 윤활유를 바릅니다.
4. 가스 리프트가 원활하게 작동하도록 책상 높이를 가끔 조정하십시오.
5. 정기적으로 나사를 확인하여 풀어진 곳이 있으면 조여서 사용하세요.
6. 가방의 지퍼가 끼어 있으면 앞뒤로 몇 번 부드럽게 잡아 당겨 문제를 해결할 수 있습니다.
7. 부식성이 있는 세척제를 사용하여 표면을 청소하는 것은 엄격히 금지되어 있습니다. 섭씨40°이하 (104° Fahrenheit)의 온수를 부드러운 세제와 함께 사용하고 청소 후 표면을 닦아서 항상 건조하게 유지 하십시오





線上組裝影片



Assembly video



kid2youth.com

**TCT NANOTEC CO., LTD 大將作國際股份有限公司**

📍 407 台中市西屯區工業區14路1號 No.1, 14th Rd., Taichung Industrial Park Taichung City 407, Taiwan

☎ +886-(0)4-23591666 📠 +886-(0)4-23591686 🌐 www.kid2youth.com 📠 統編 8040 8563