



G 系列使用手冊 Operation manual

TCT NANOTEC CO., LTD 大將作國際股份有限公司

407 台中市西屯區工業區14路1號 No.1, 14th Rd., Taichung Industrial Park Taichung City 407, Taiwan

+886-(0)4-23591666 +886-(0)4-23591686 www.kid2youth.com 8040 8563



線上組裝影片



Assembly video



kid2youth.com

G2C+/G6+/G6C+ 系列組裝說明



注意

- 適用年齡4歲以上。
- 請由成人組裝並注意孩童安全。
- 孩童使用時務必由成人陪同。

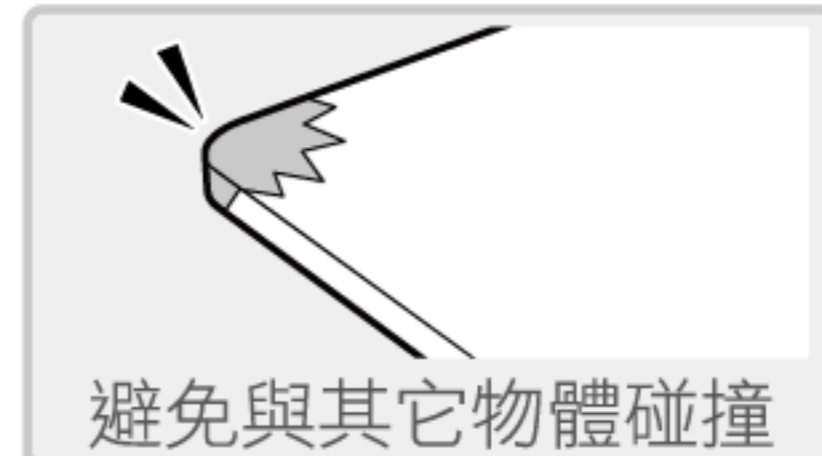

1 桌板

G2C+ | XXS
XS

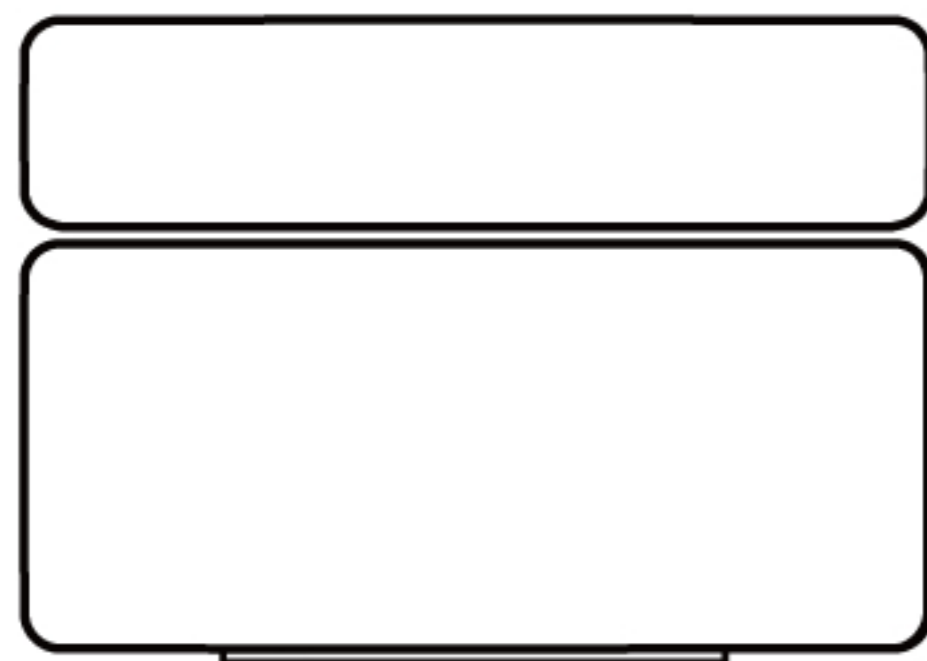

G6+ | XS
S

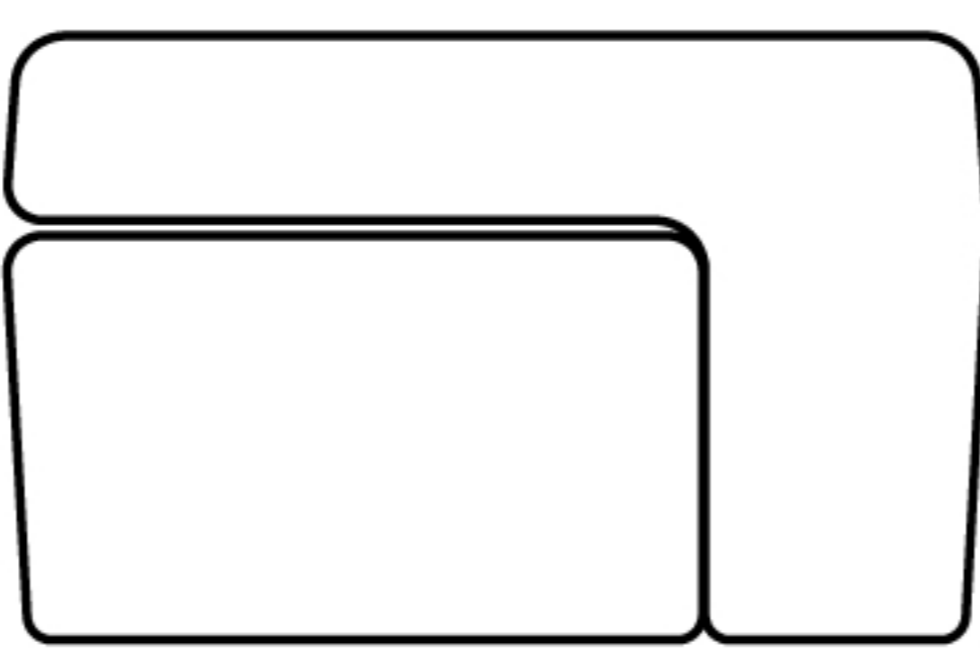

G6C+ | XS
S

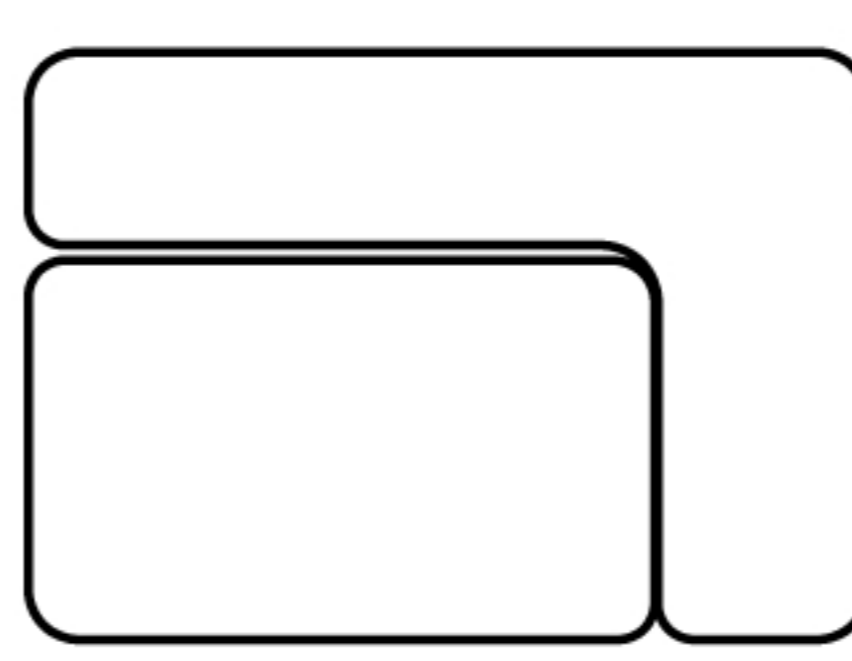

2 緩衝棒

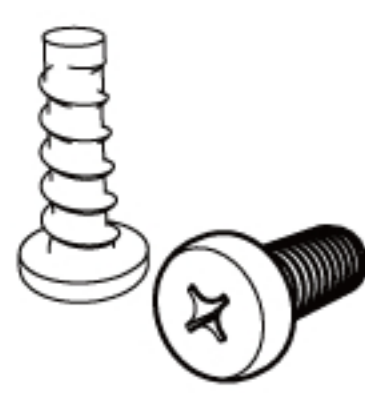

H 螺絲
4.8*14mm

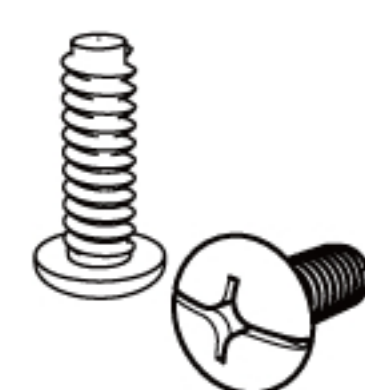

E 螺絲
M4*12mm

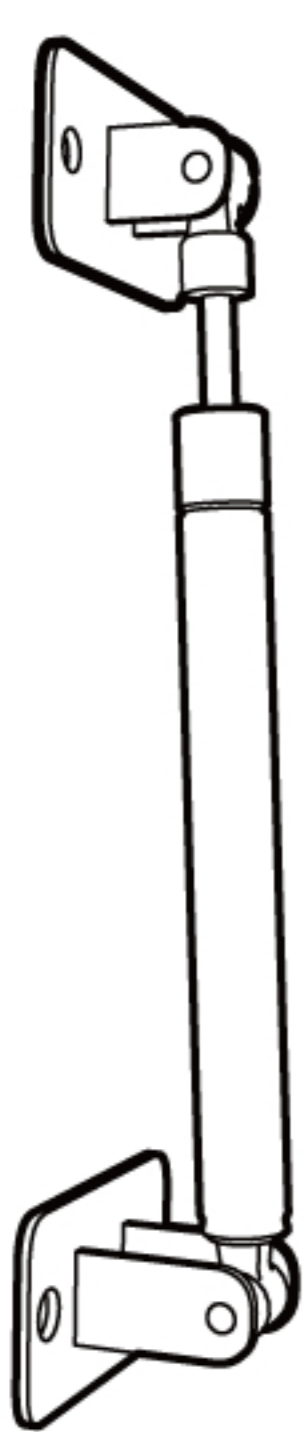

3 桌腳

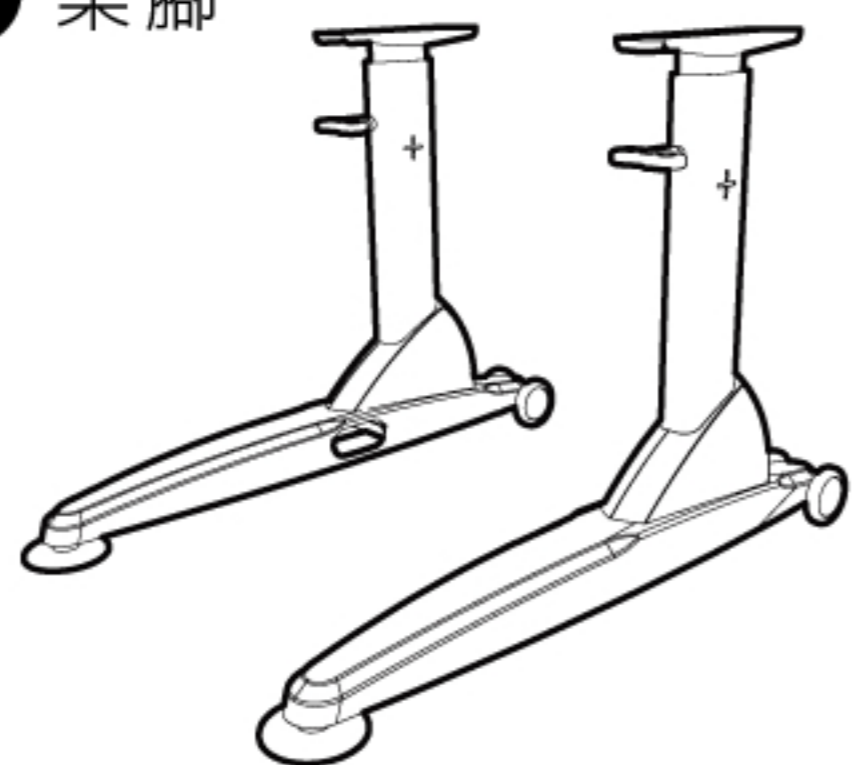

4 下橫桿

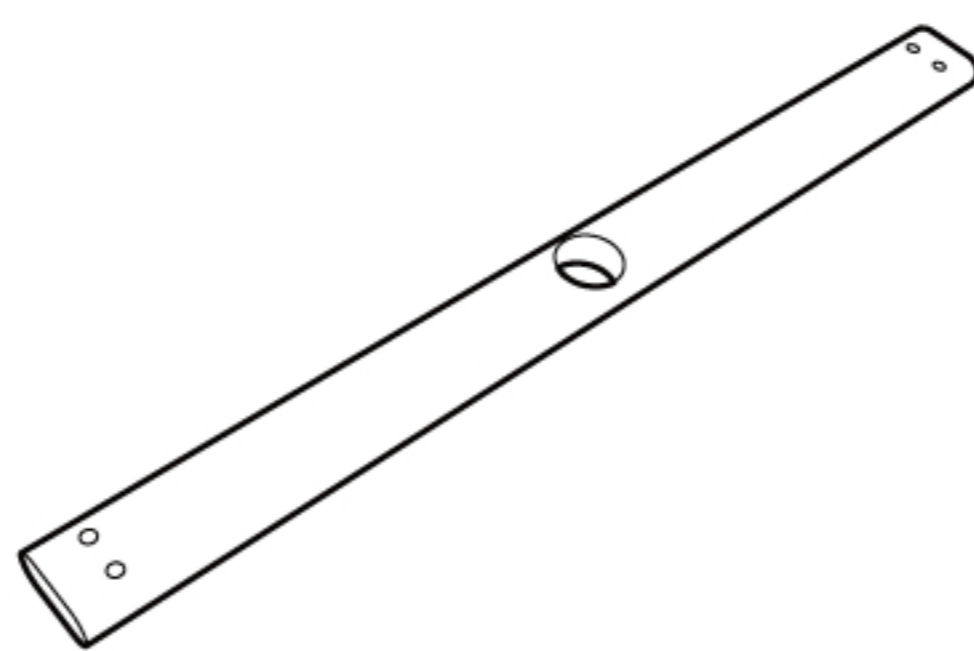

5 護盤

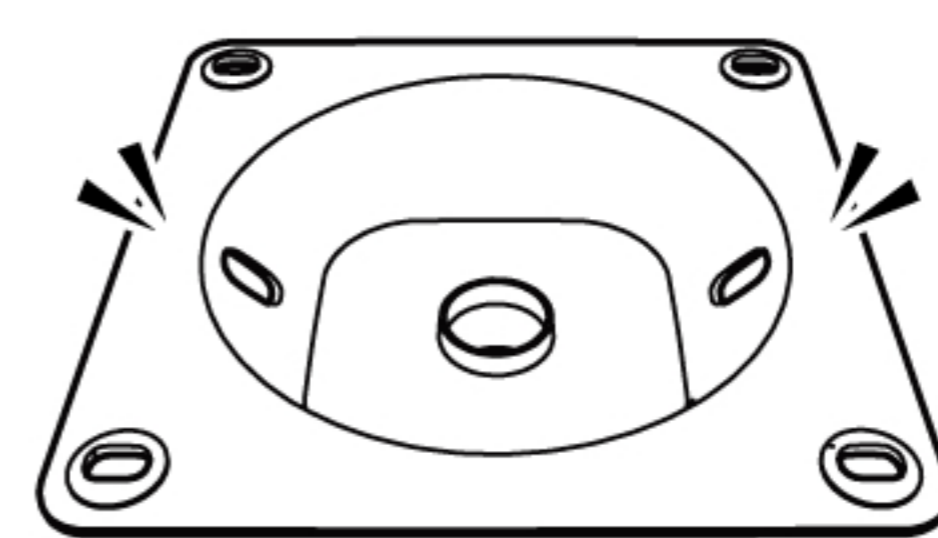

6 氣壓棒

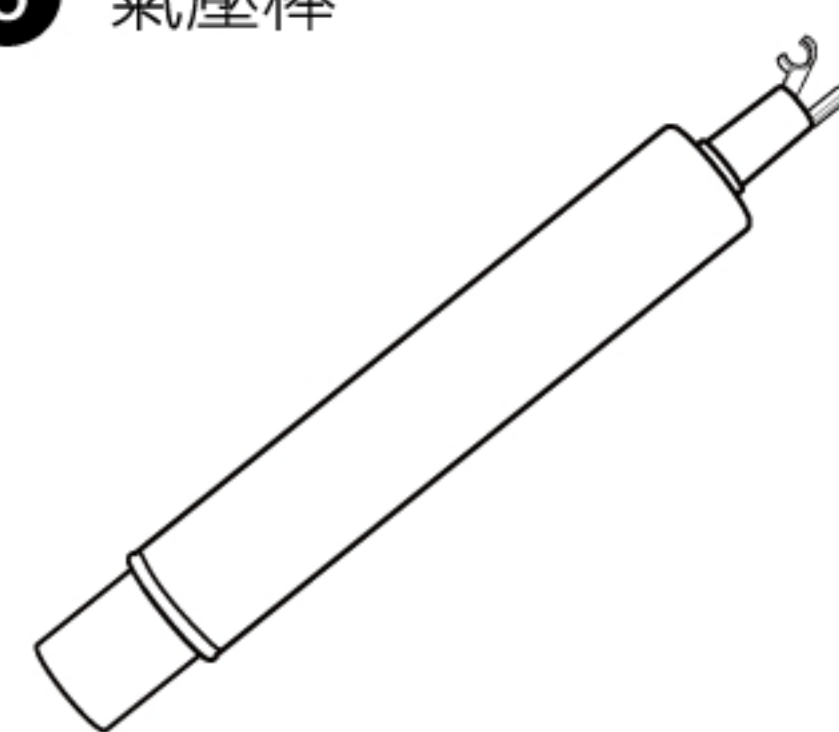

7 線控拉把

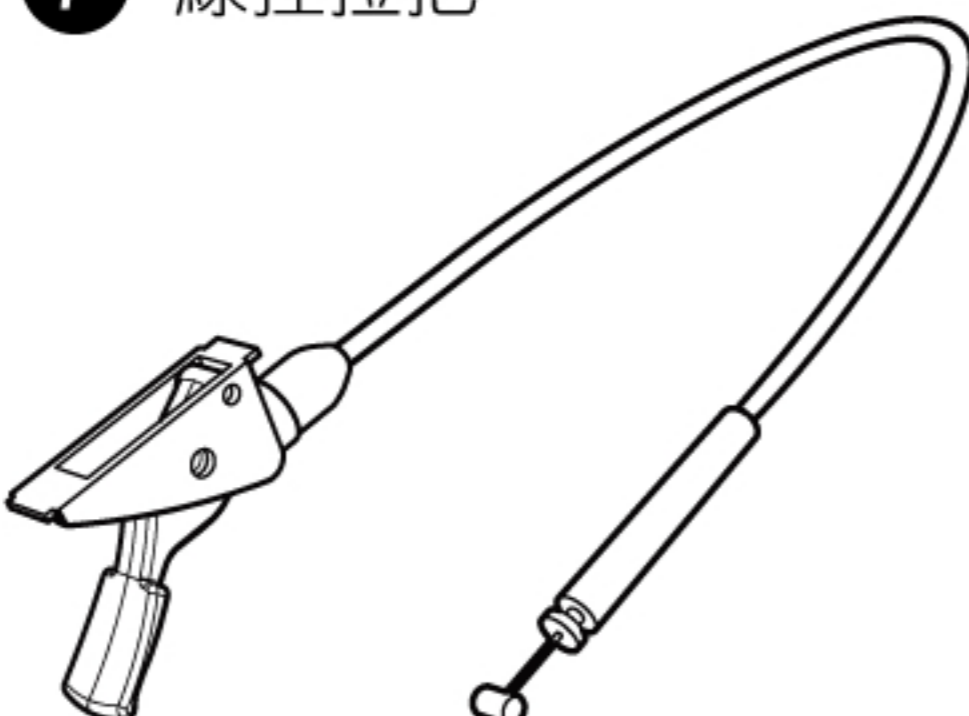

8 S 收納槽

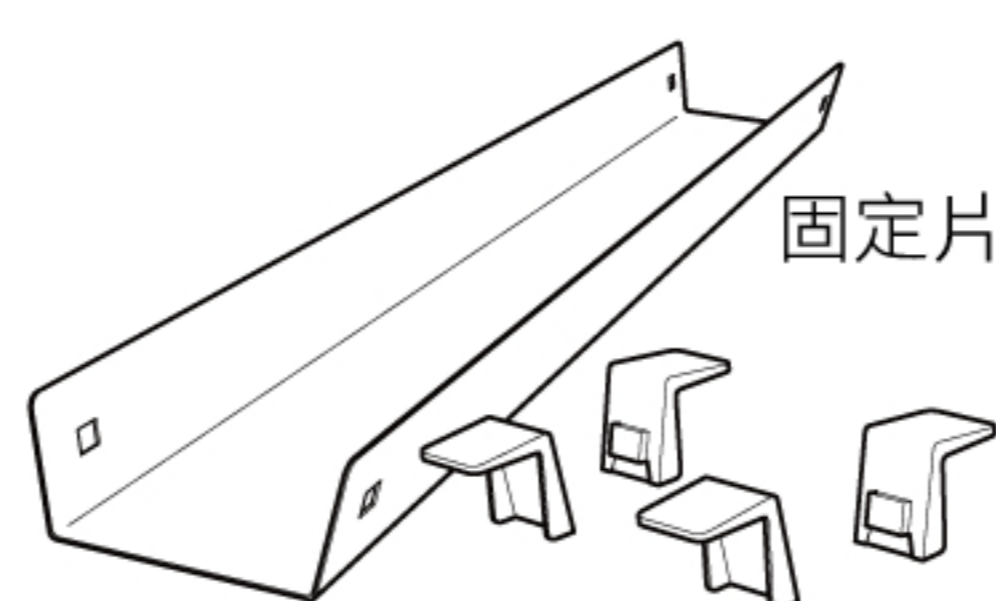

9 護腕尺

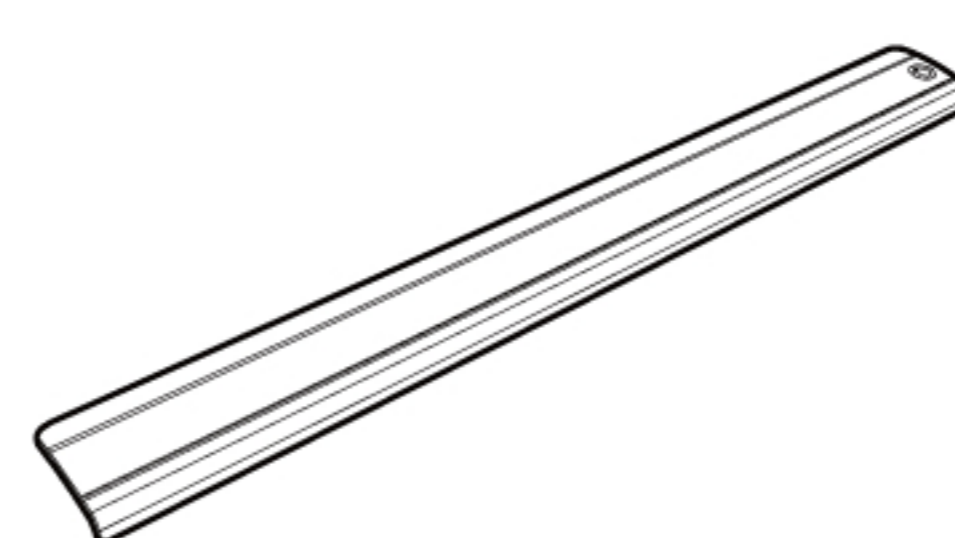

五金包



六角板手 NO.4

A 桌腳螺絲 X 4

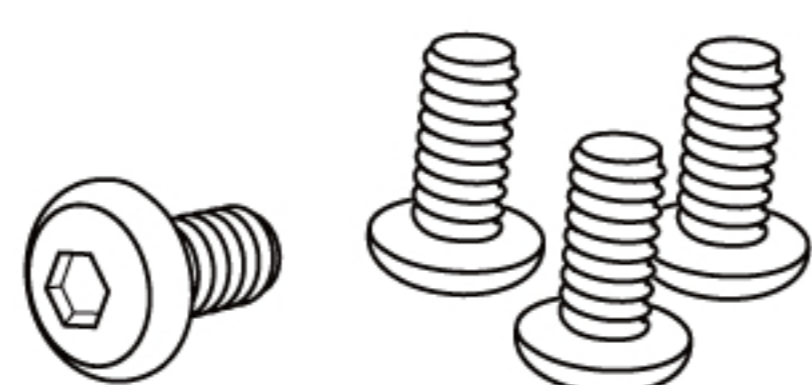

1/4*15mm

A 護盤螺絲 X 4

B 華司 X 4



1/4*15mm

C 下橫桿螺絲 X 4

D 華司 X 4



M8*38mm

1 先拉開文具抽，將緩衝棒 2 對齊螺絲孔並鎖上螺絲 H/E

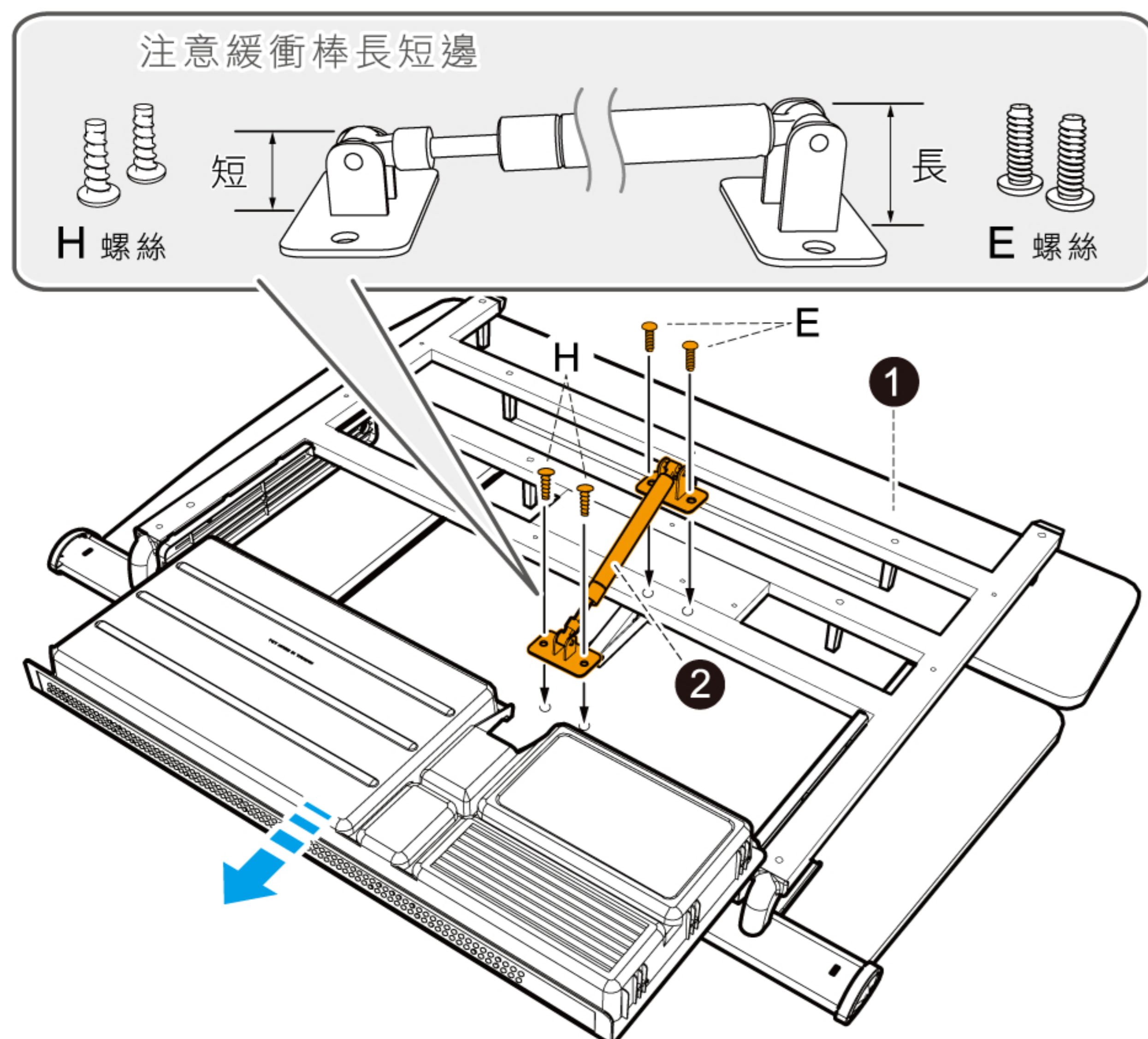

2 將護盤 5 插入氣壓棒 6，再將線控拉把 7 置入護盤 5。

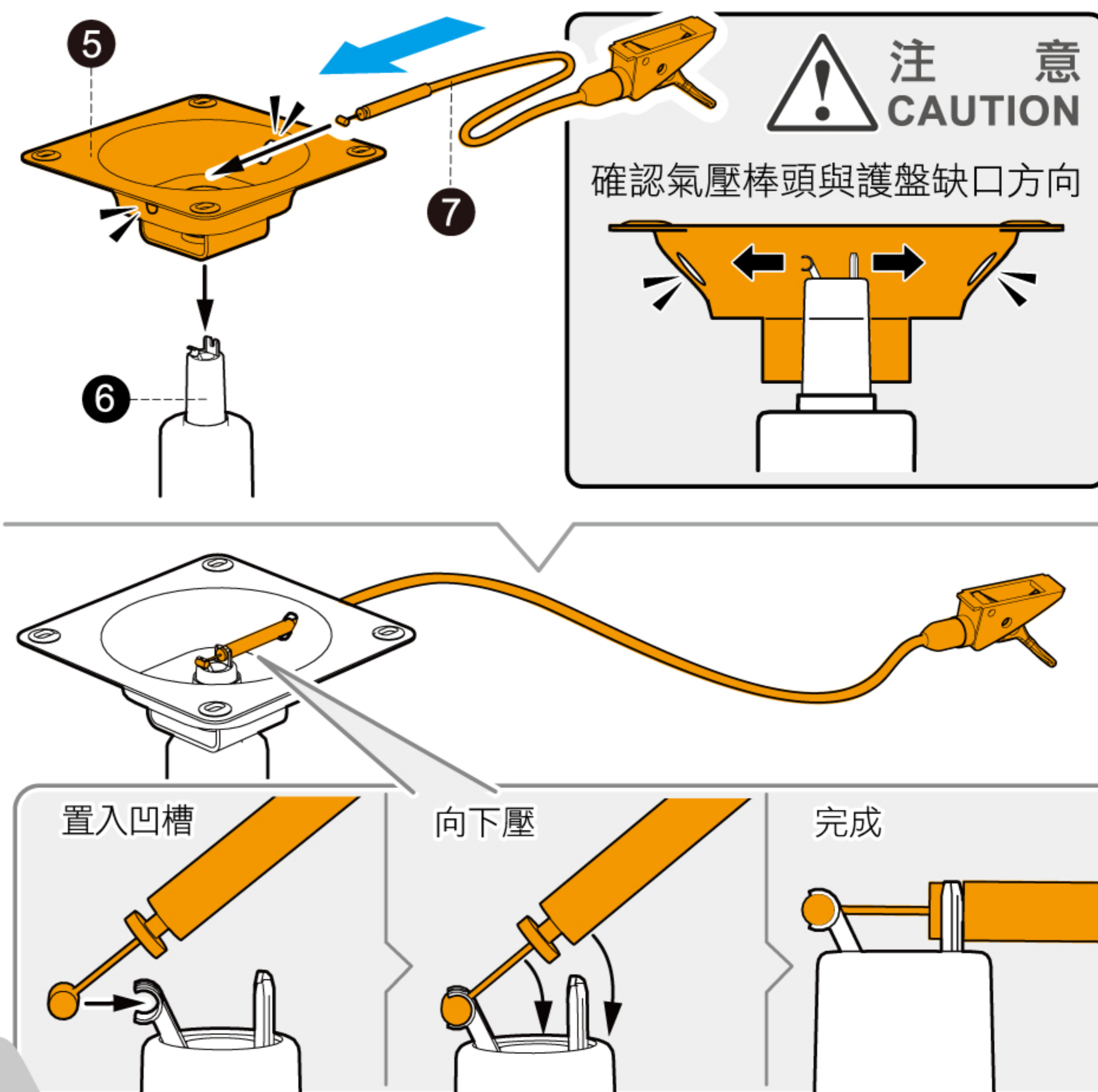

注意
CAUTION

確認氣壓棒頭與護盤缺口方向

置入凹槽

向下壓

完成

3 螺絲 A / B 依序鎖上

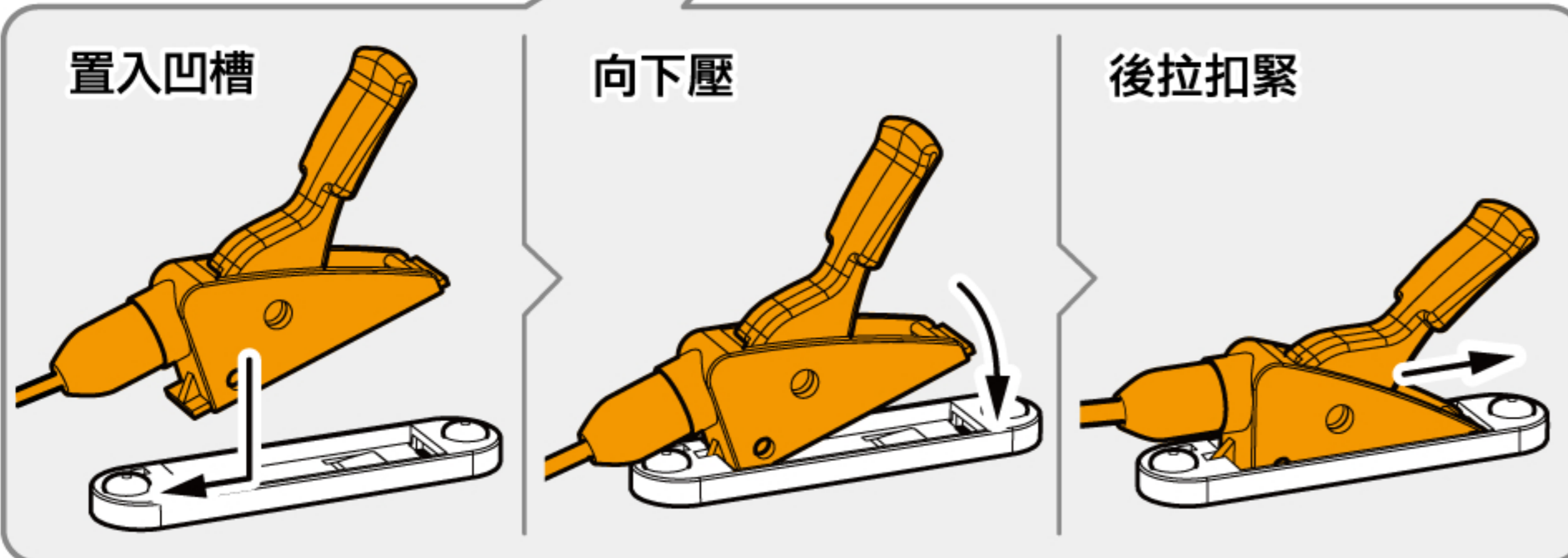
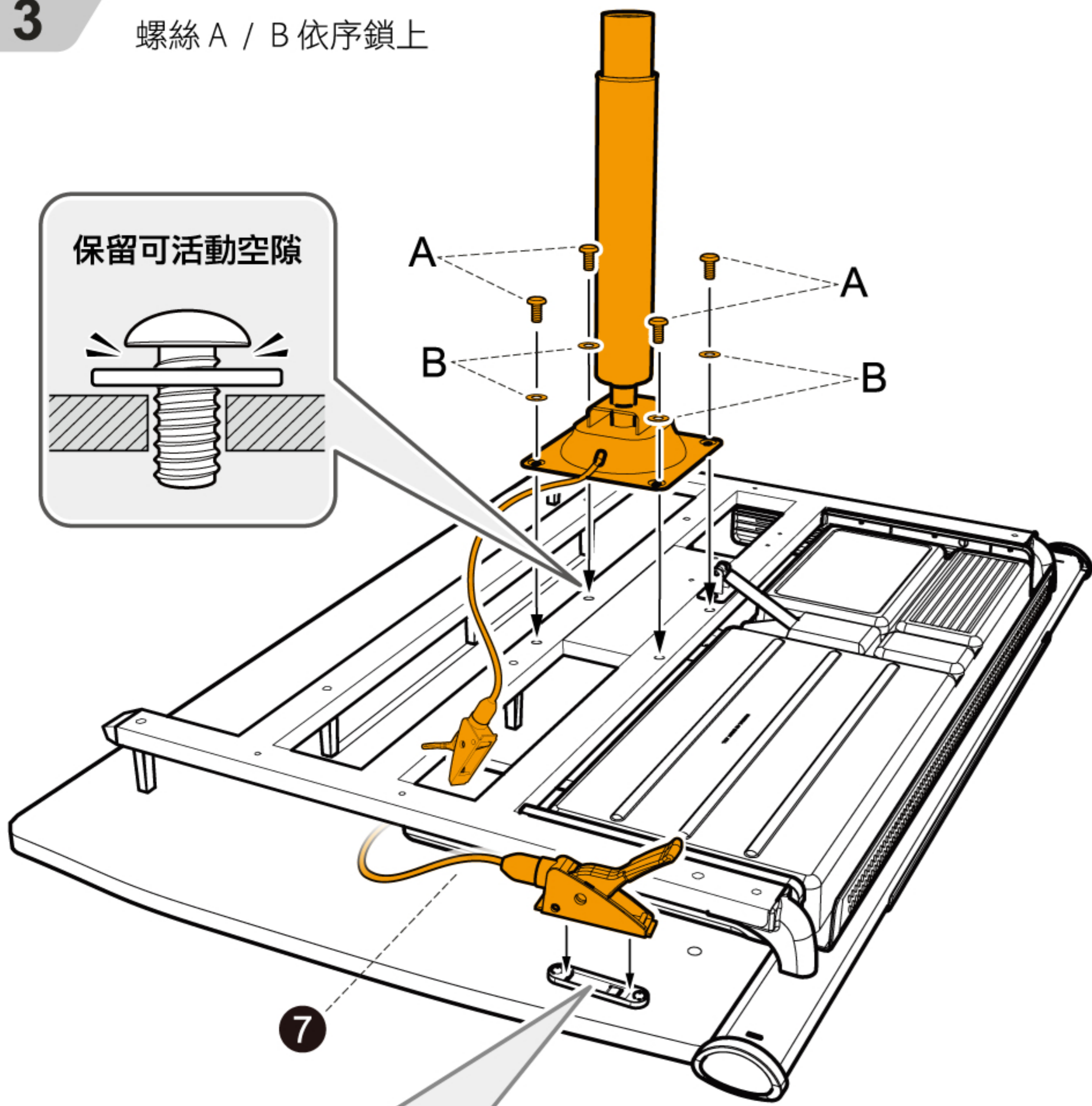

4

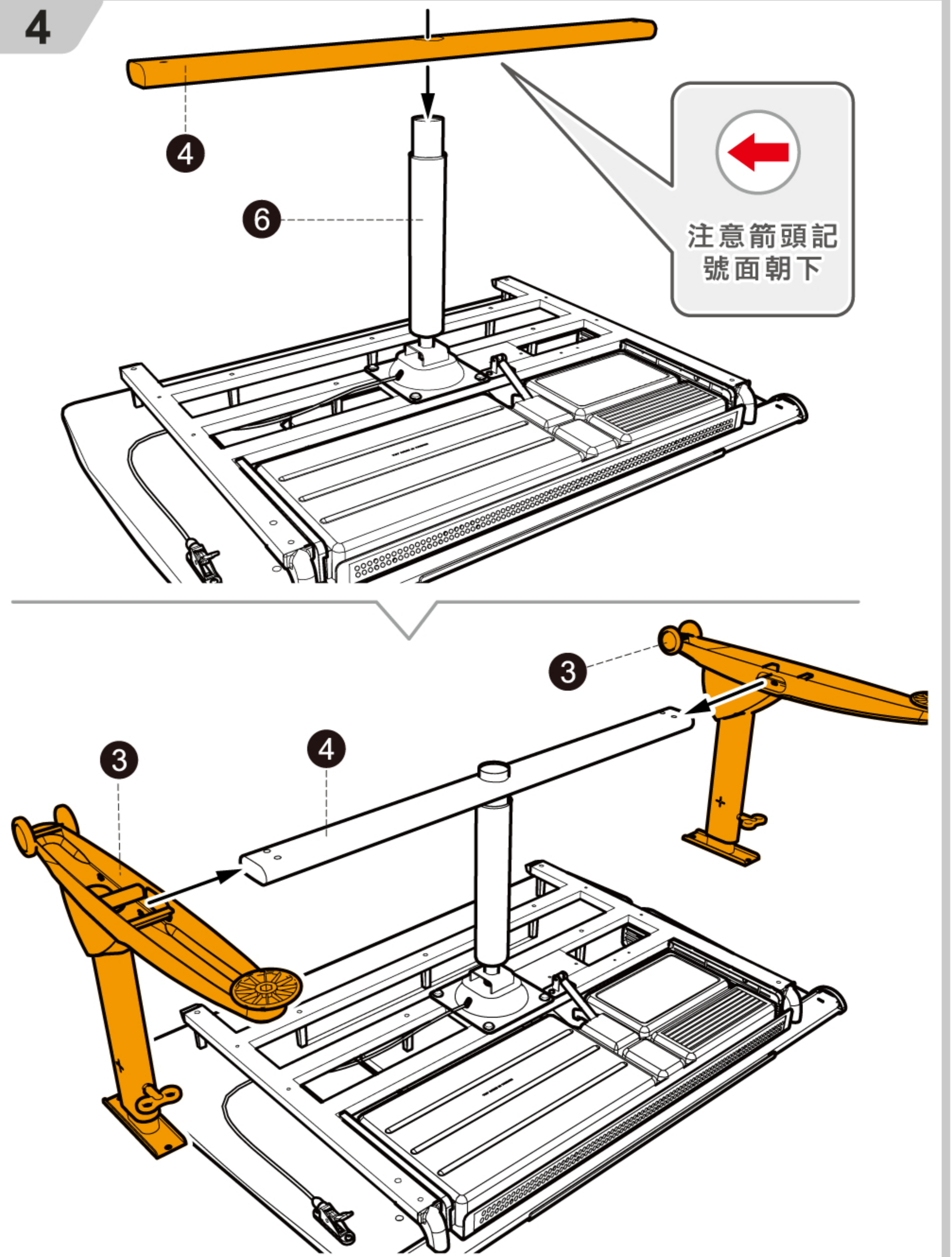

5 檢查組合處是否密合



注意
CAUTION

檢查桌腳是否水平

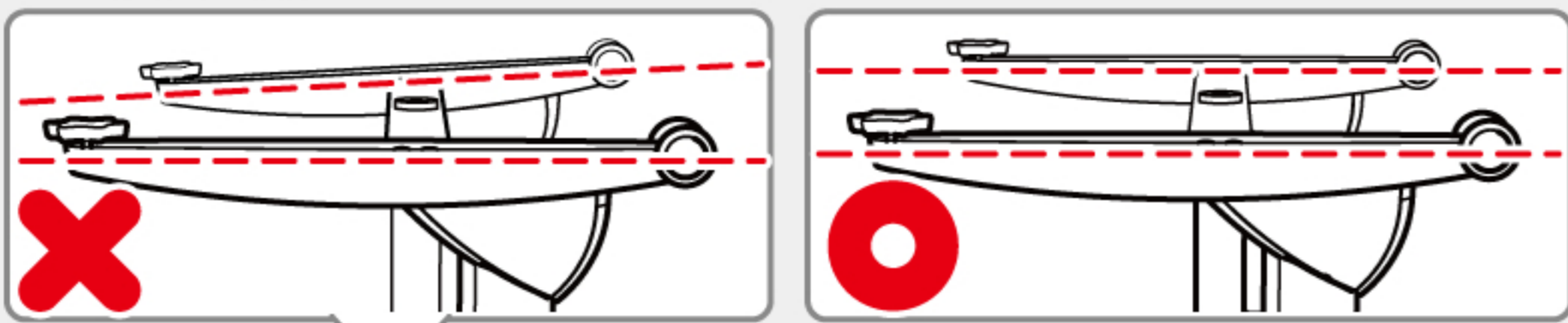

若桌腳呈現非水平狀態:

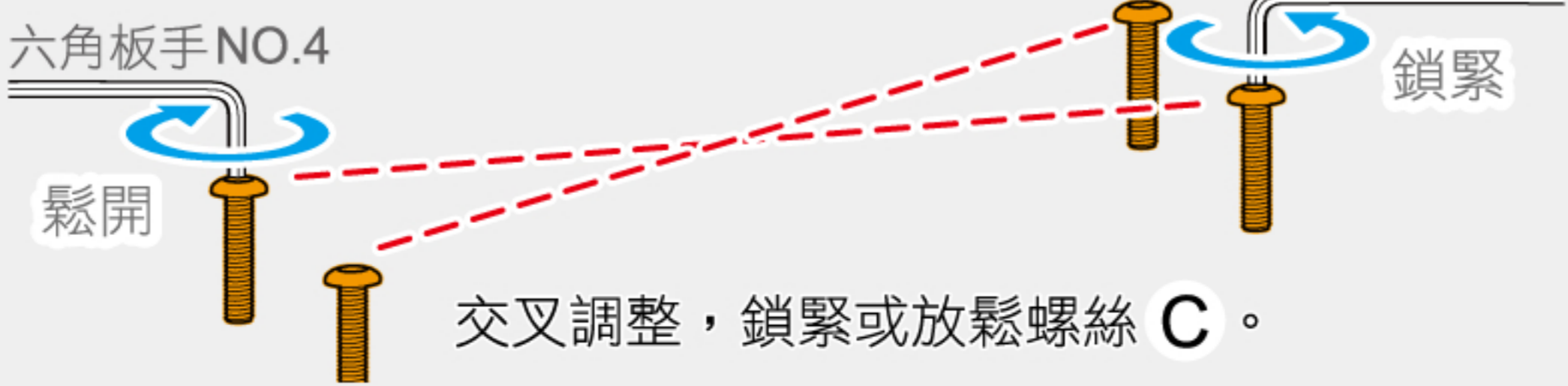

6

步驟1 鬆開把手。
步驟2 扶住內部鋼管輕放至桌板結構上。

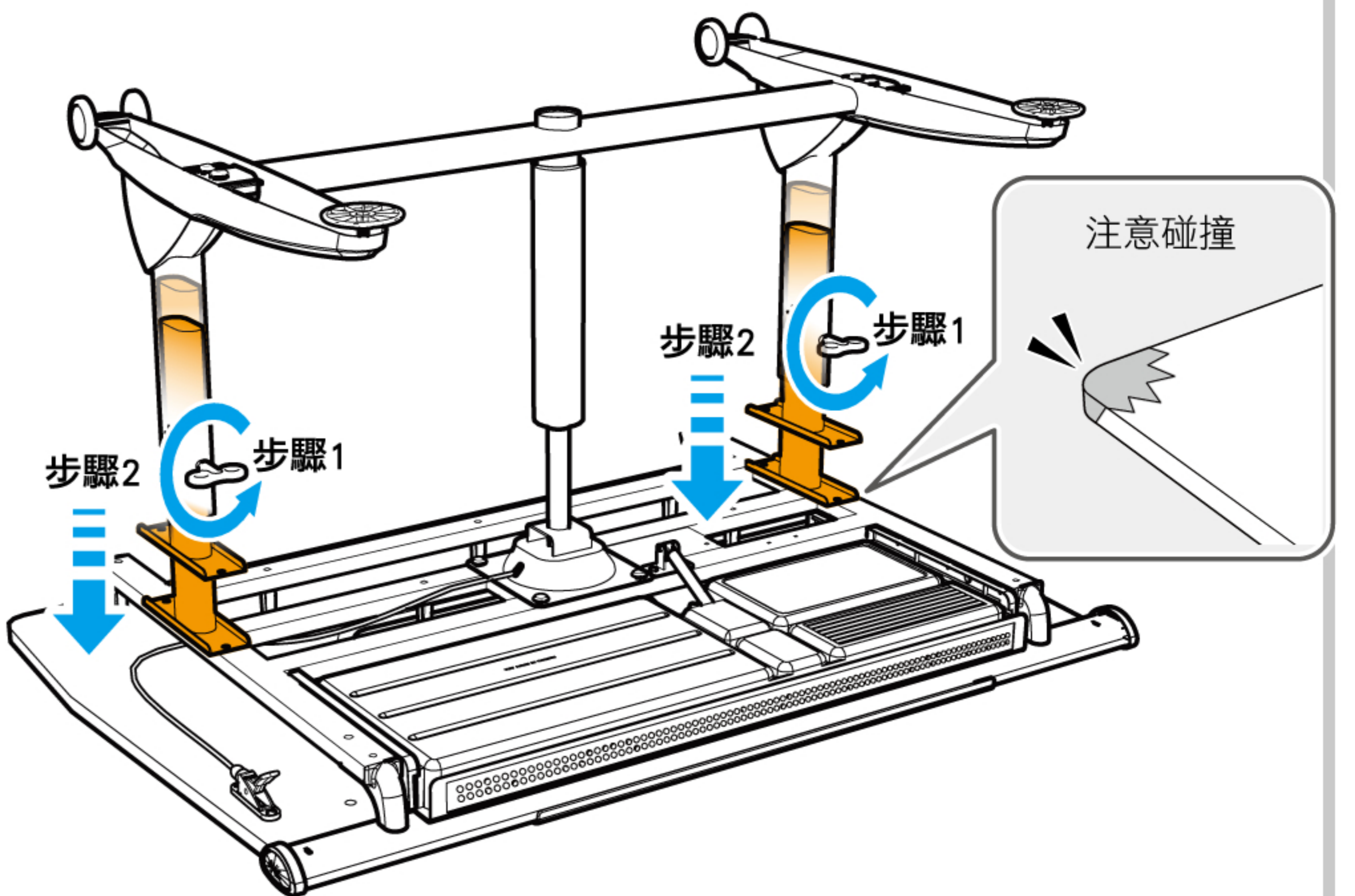

螺絲 C / D 依序鎖上

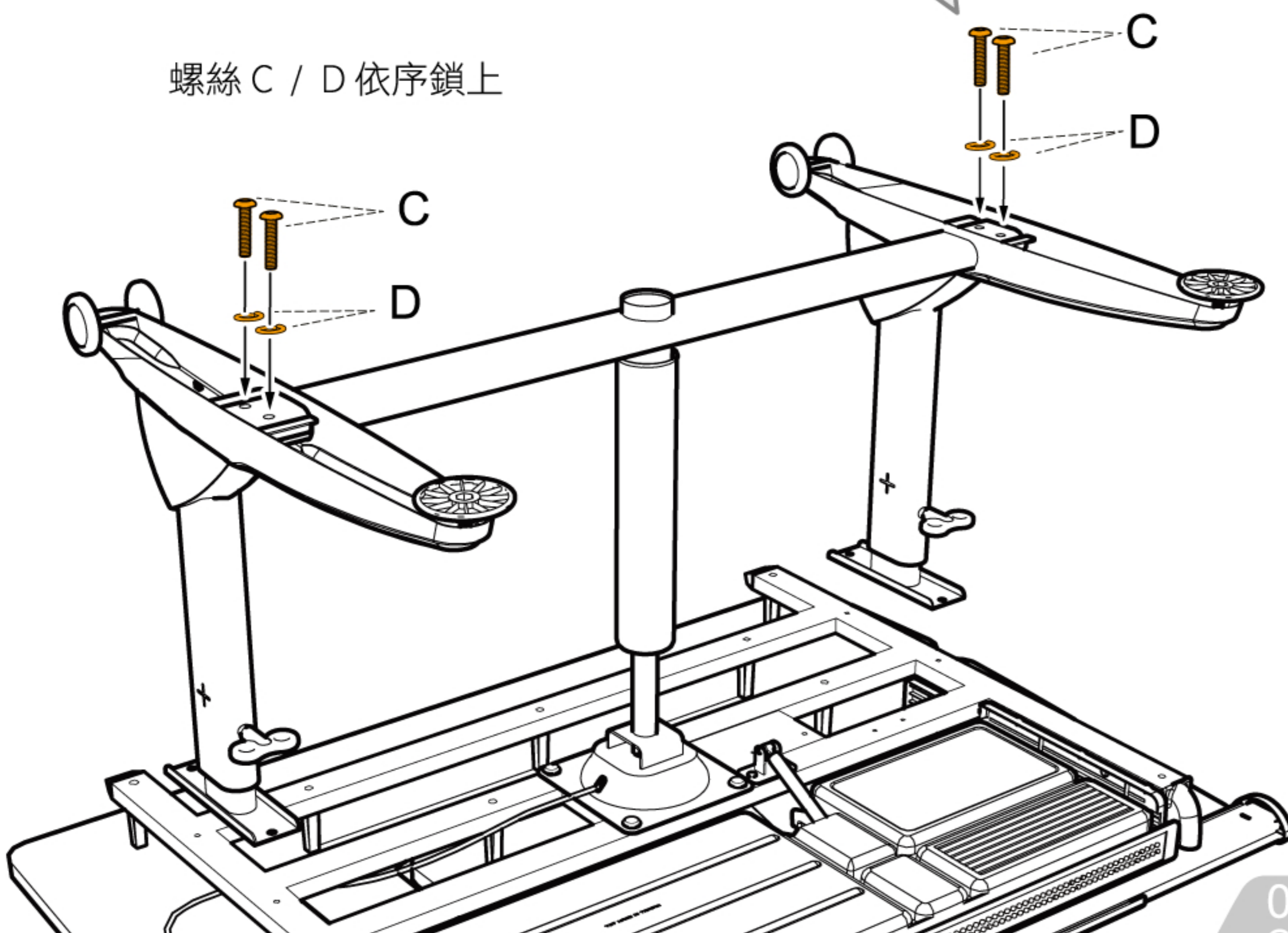

將螺絲 A 半固定鎖上

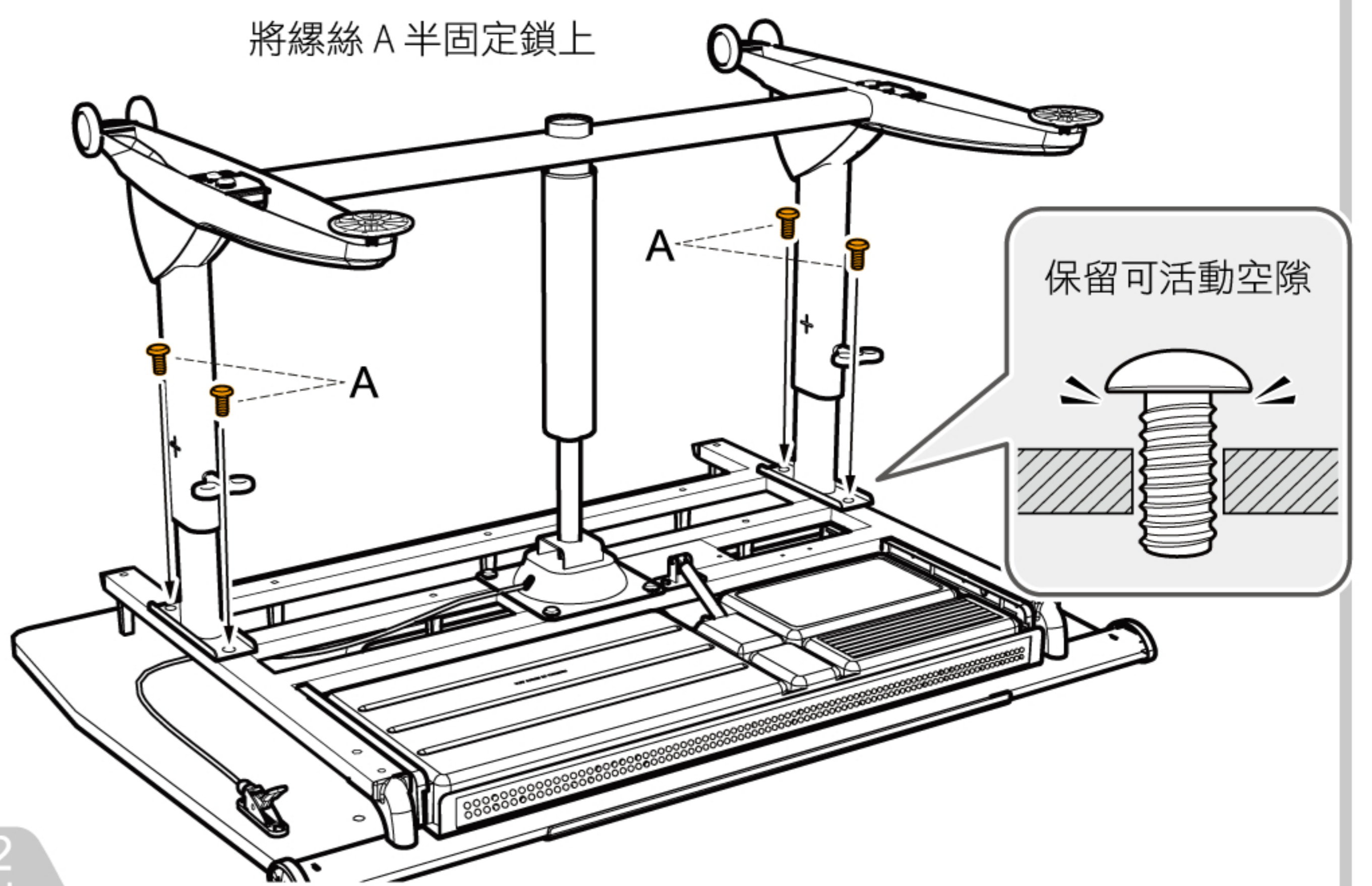

7 步驟1 拉住線控拉把，重覆升降，測試桌腳升降是否順暢。
 步驟2 將所有半固定螺絲鎖緊。

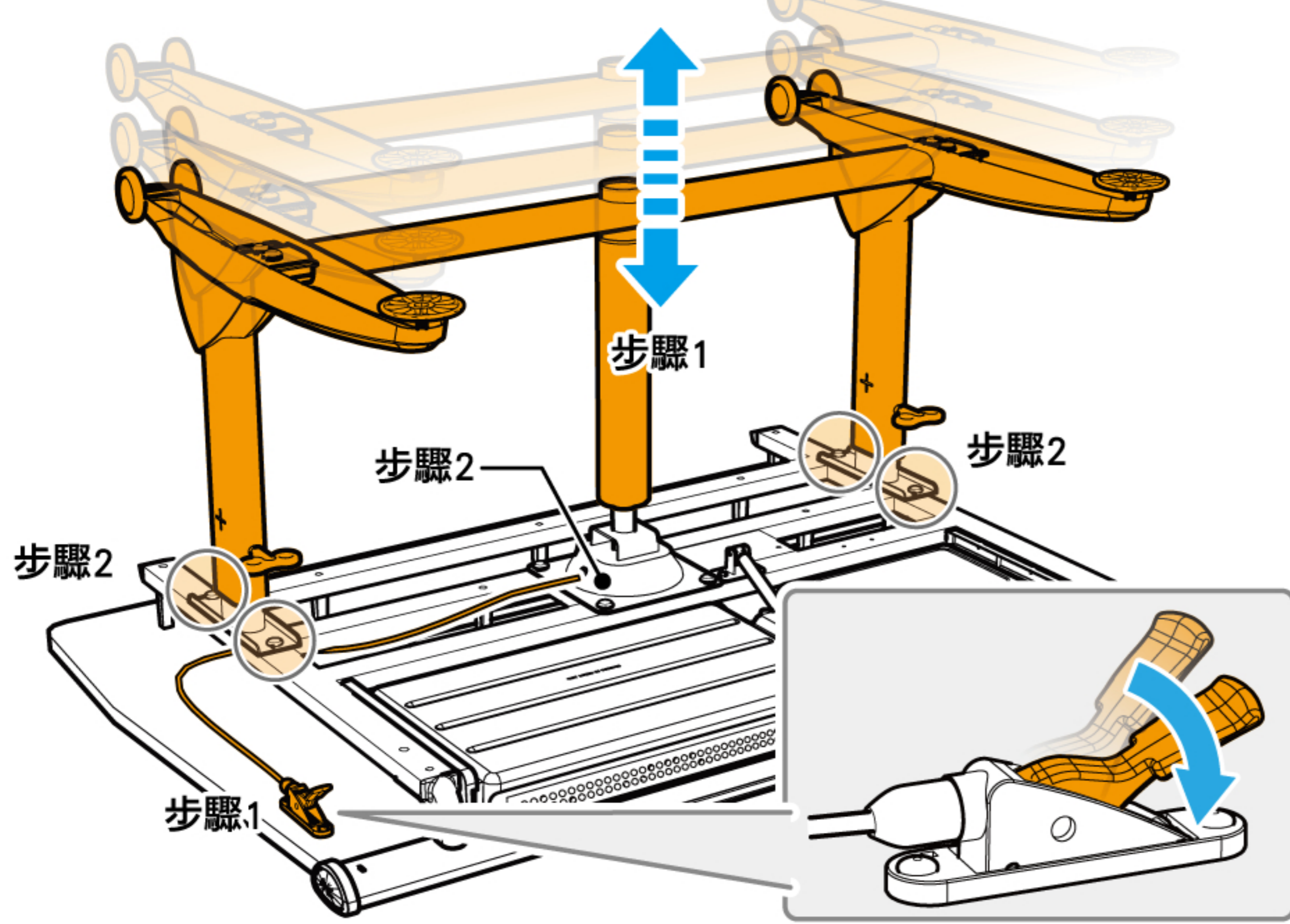

8

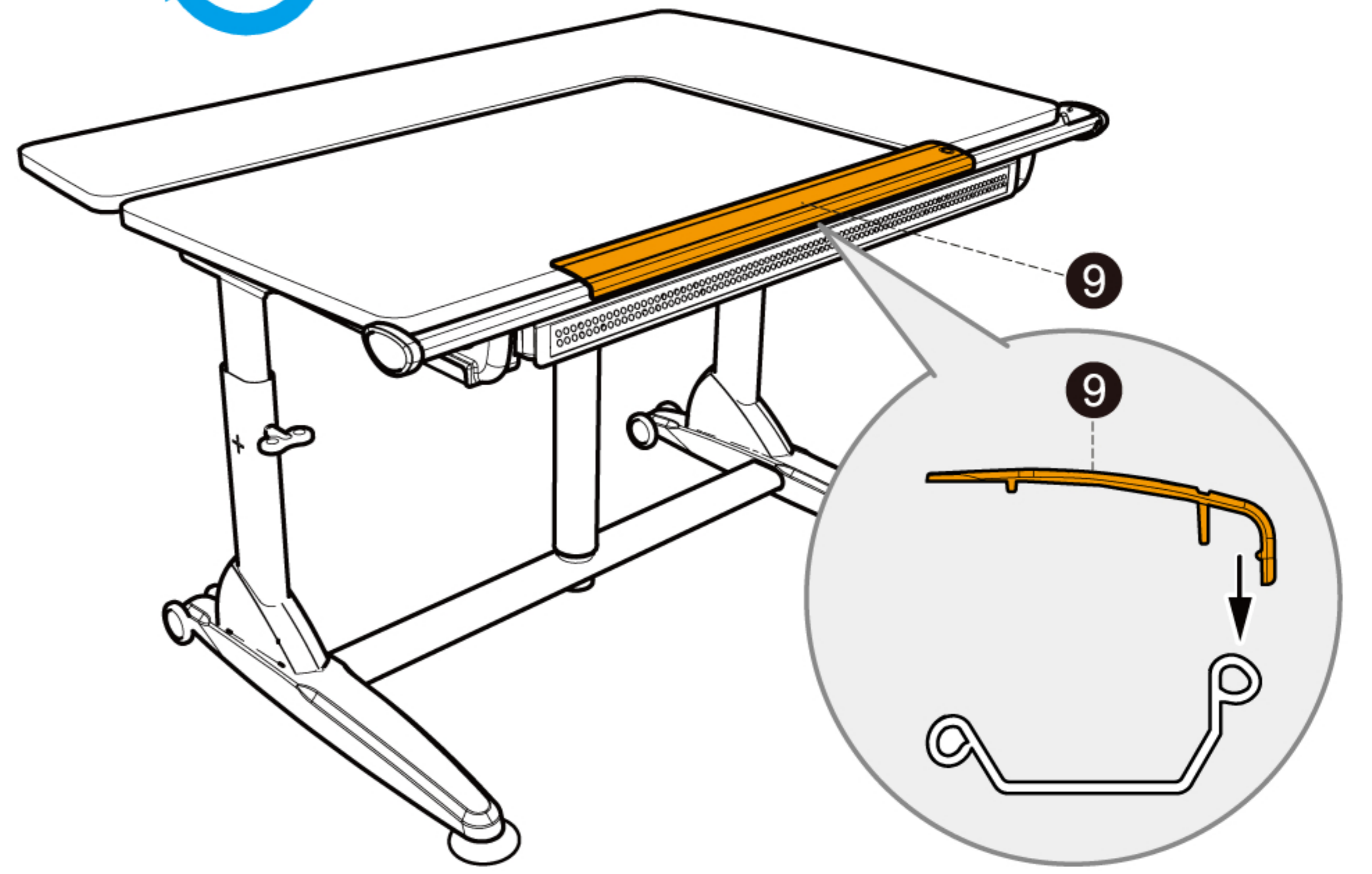

負載使用說明

重量請平均分散。

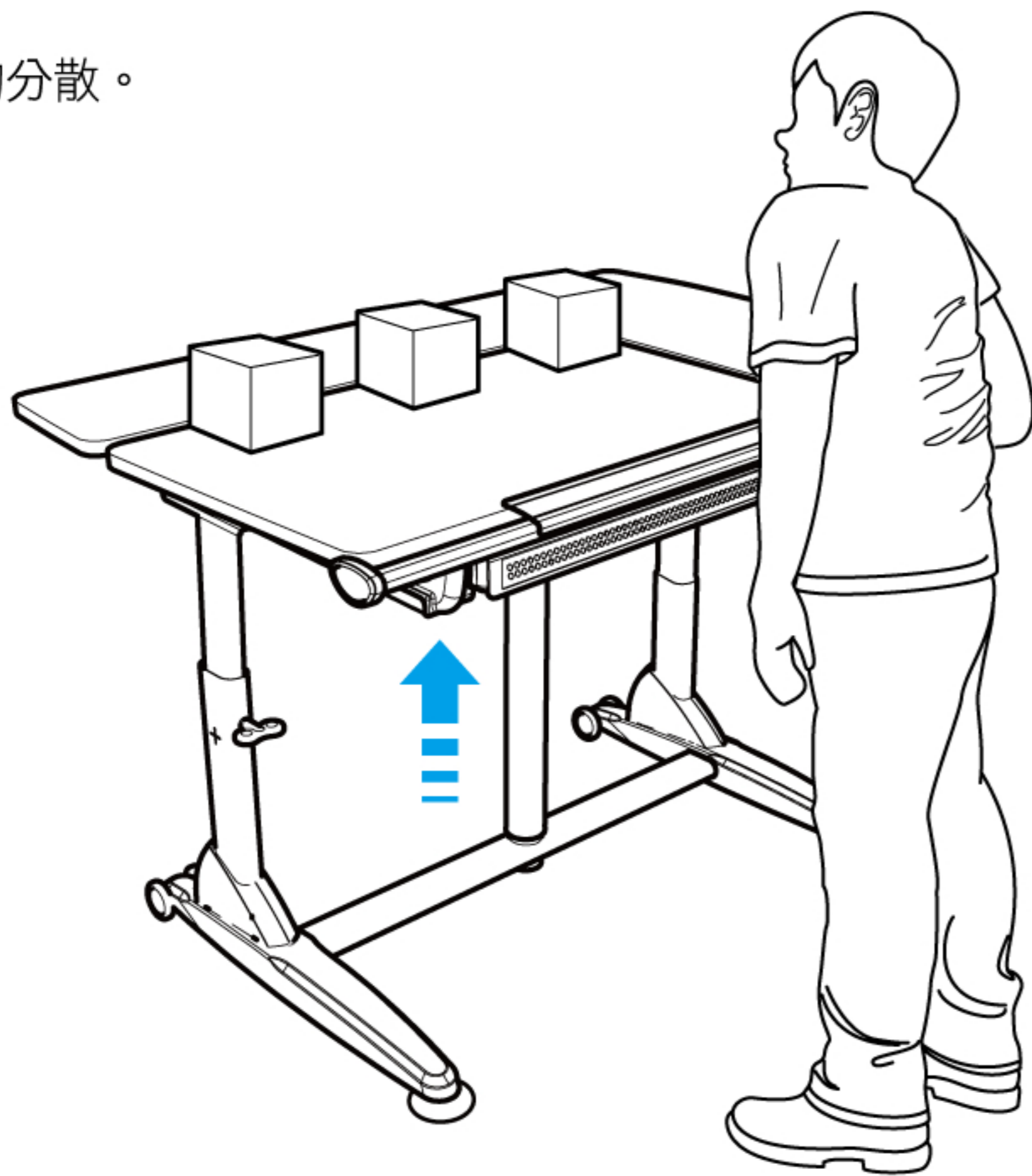

重量過重時，升起需要輔助。

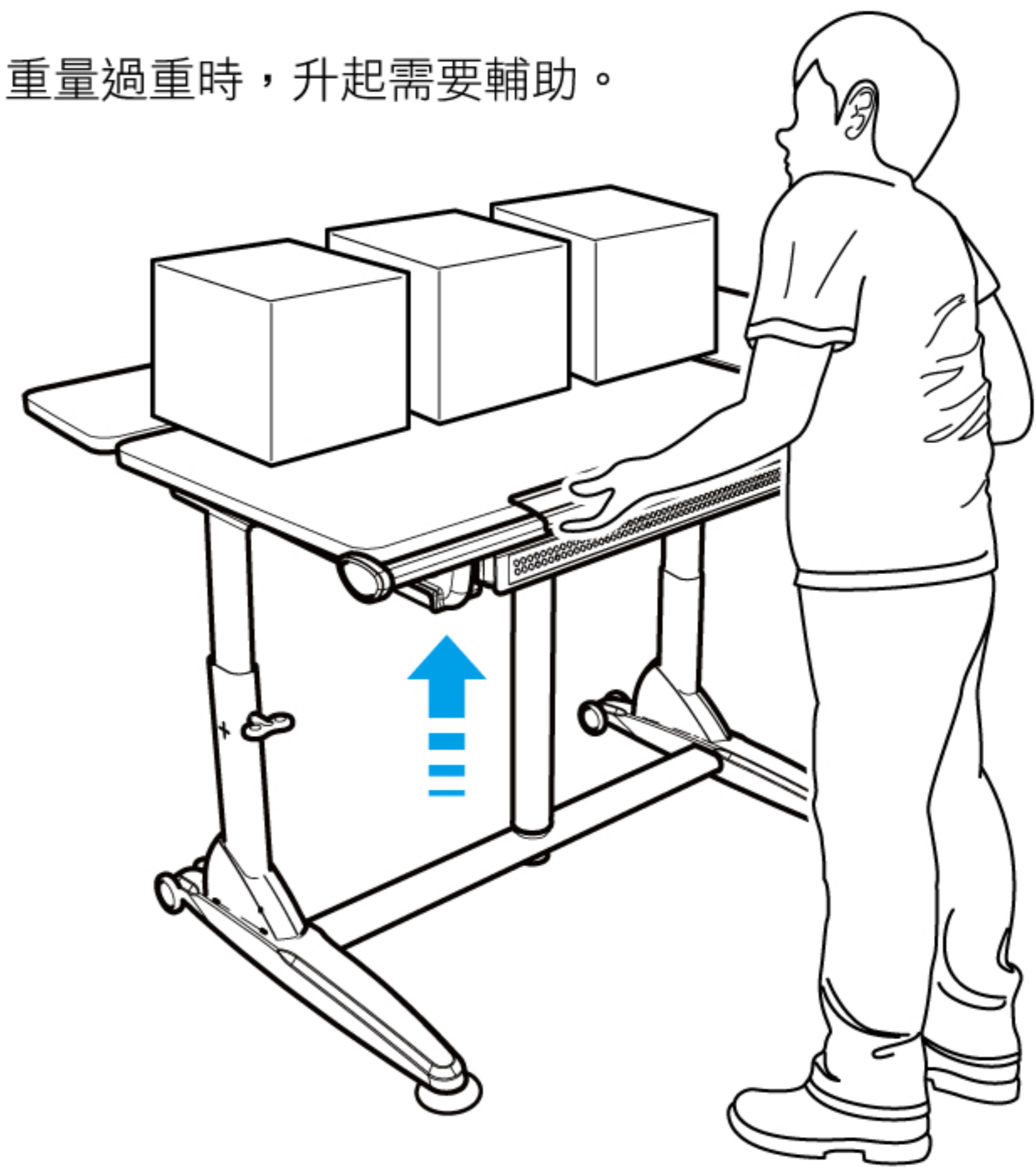

掀板使用說明

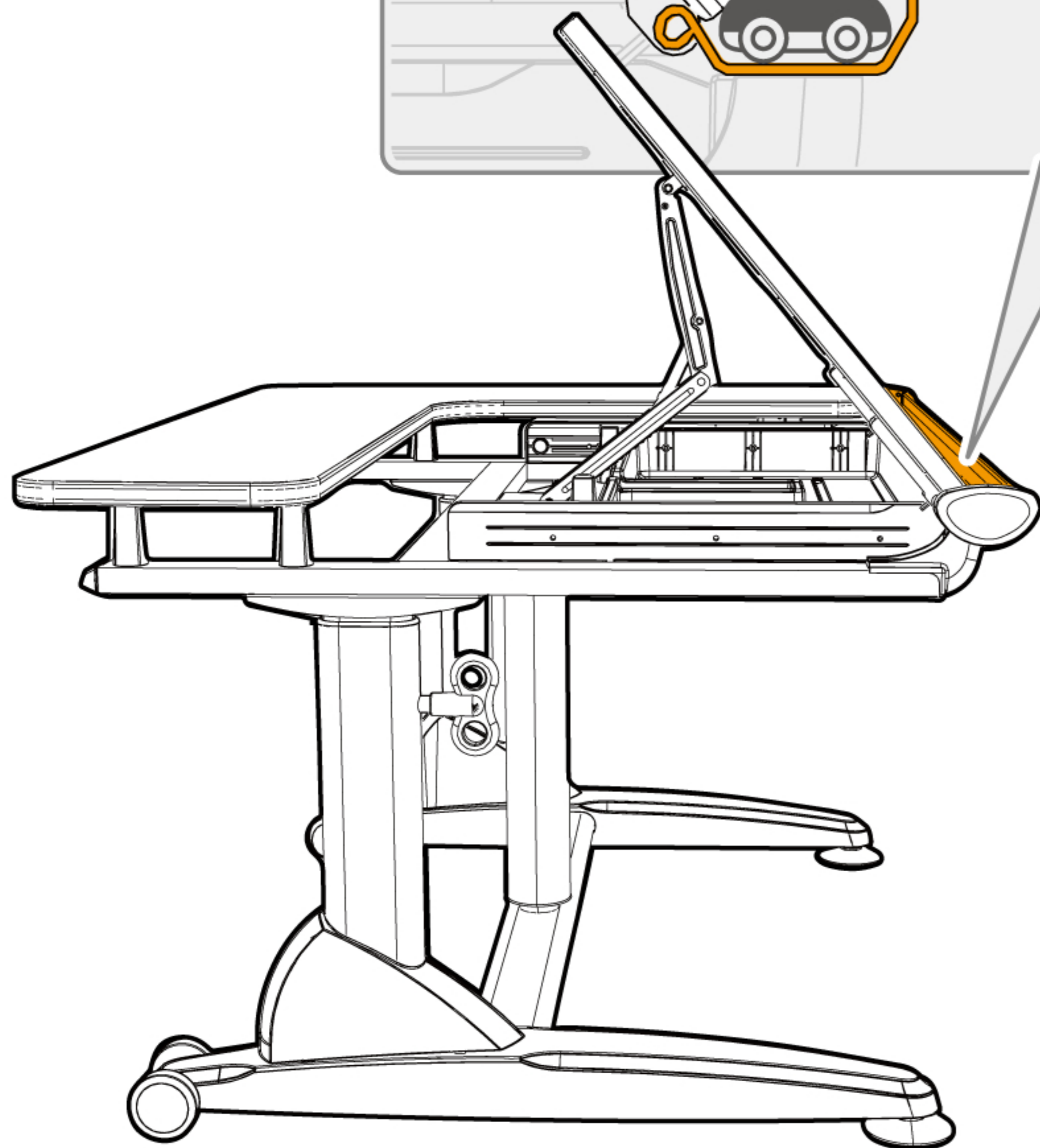

當桌板因此卡住時，扳動角度五金上的絞鍊件即可下放小桌板，切忌強硬扳動。

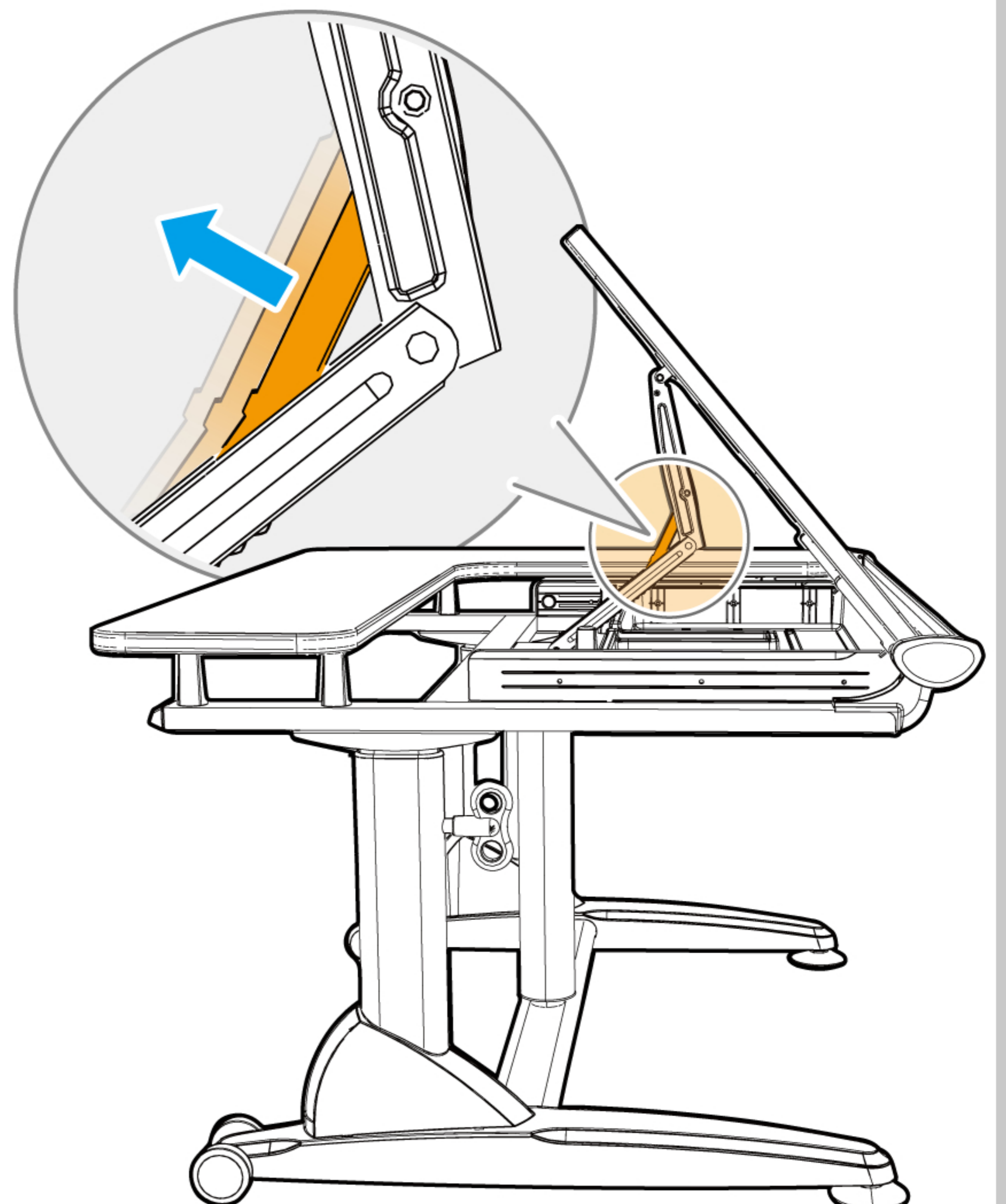

高度調整

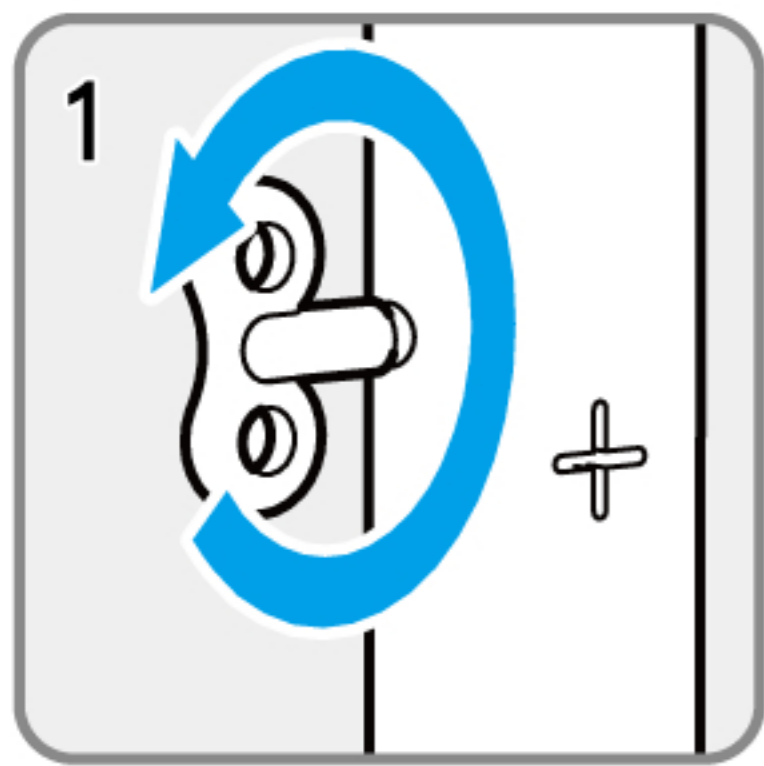

鬆開

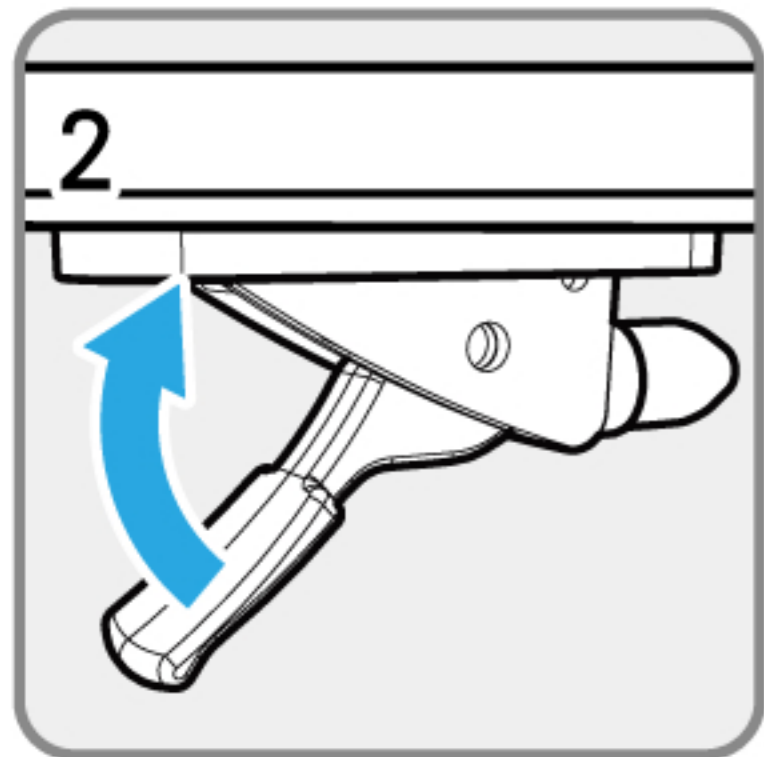

上壓

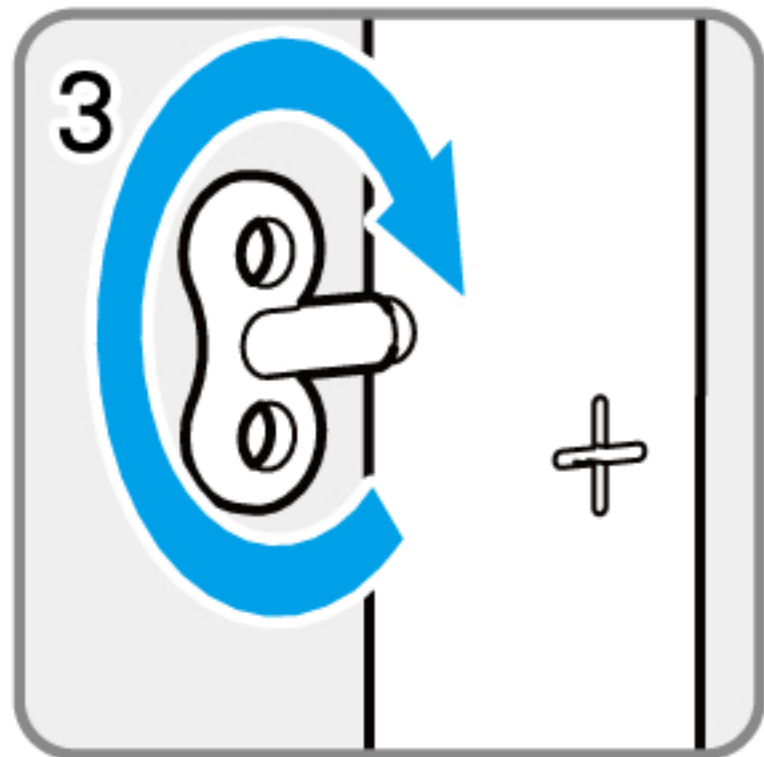

鎖緊

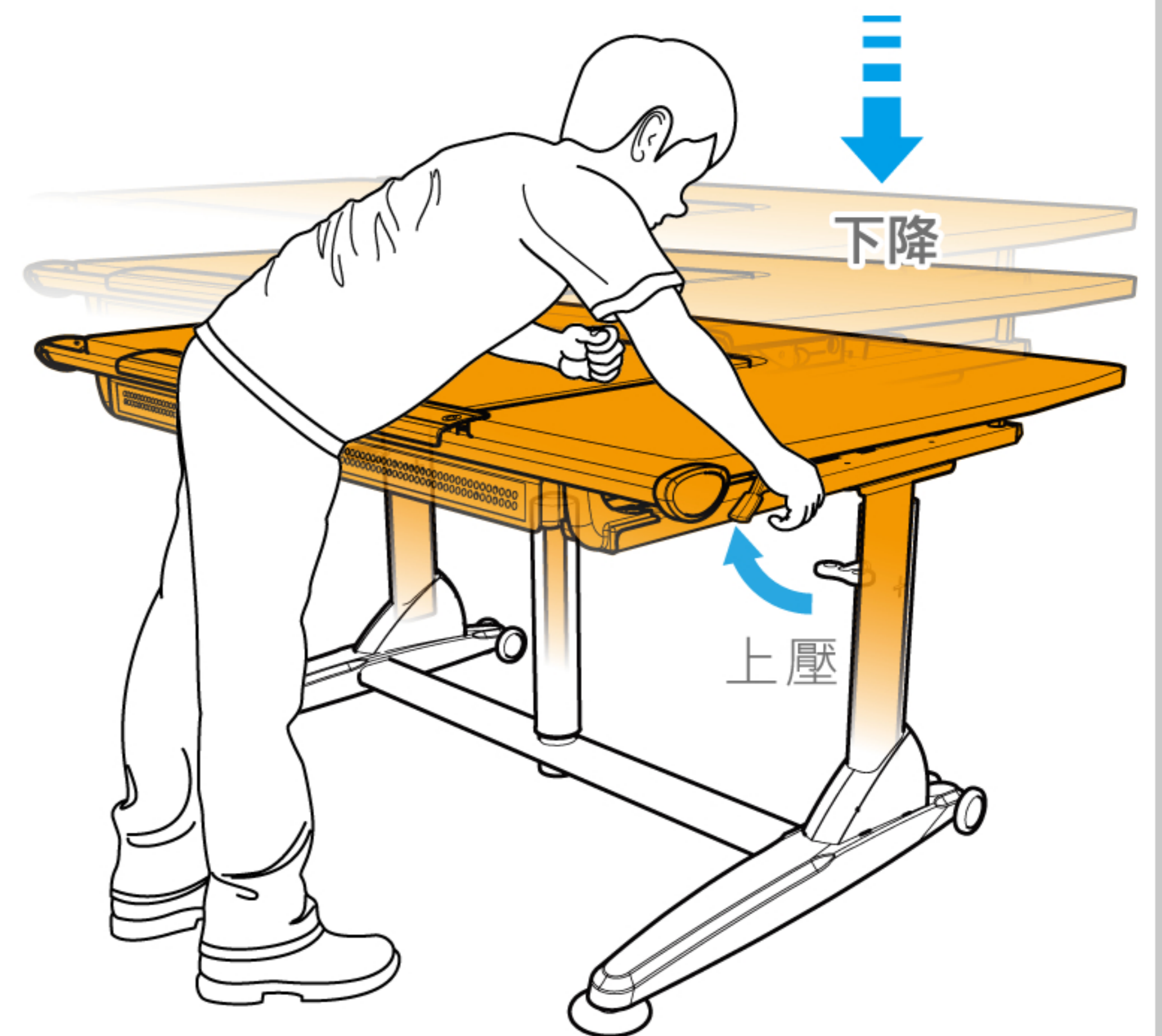
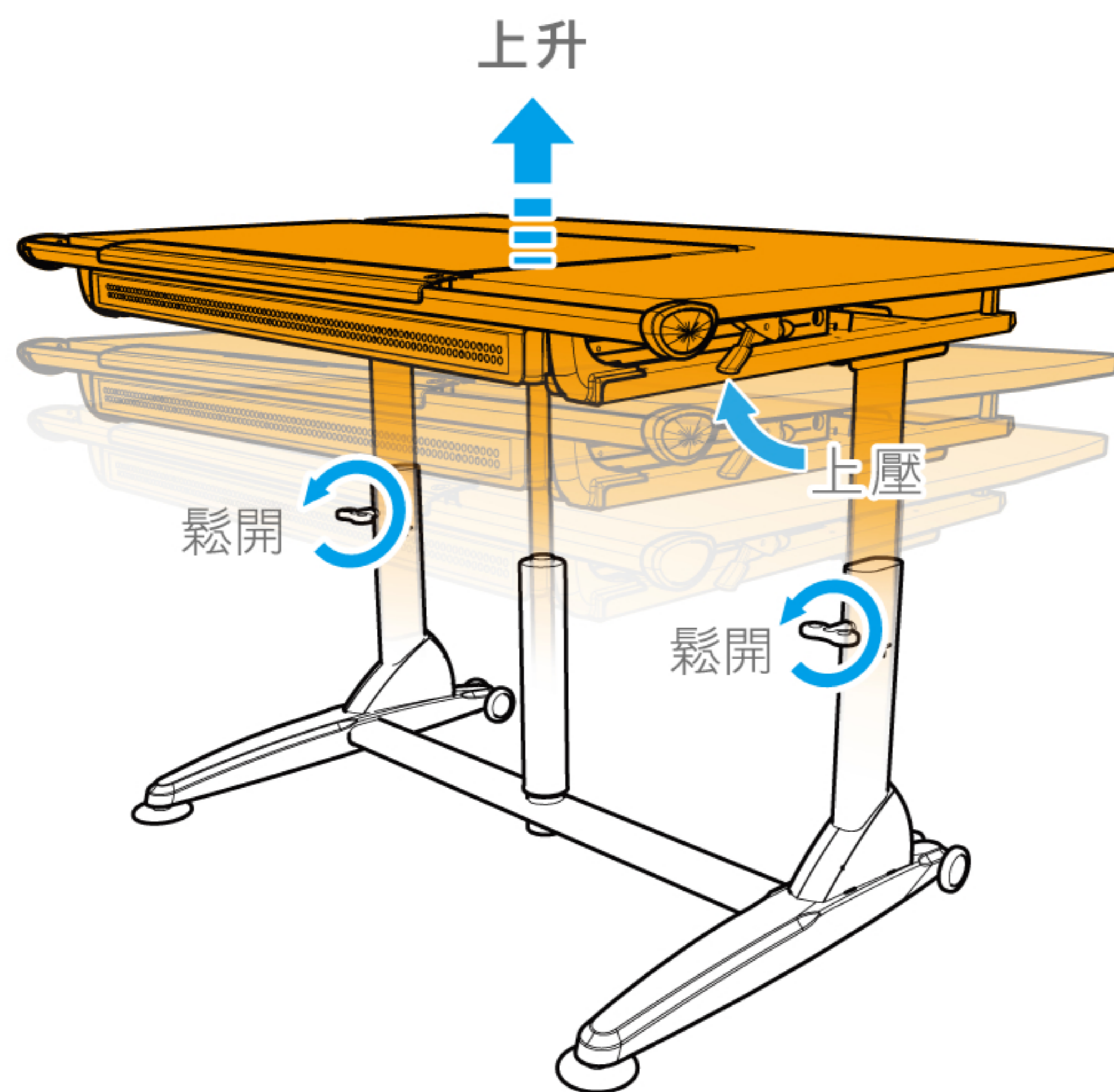

角度調整

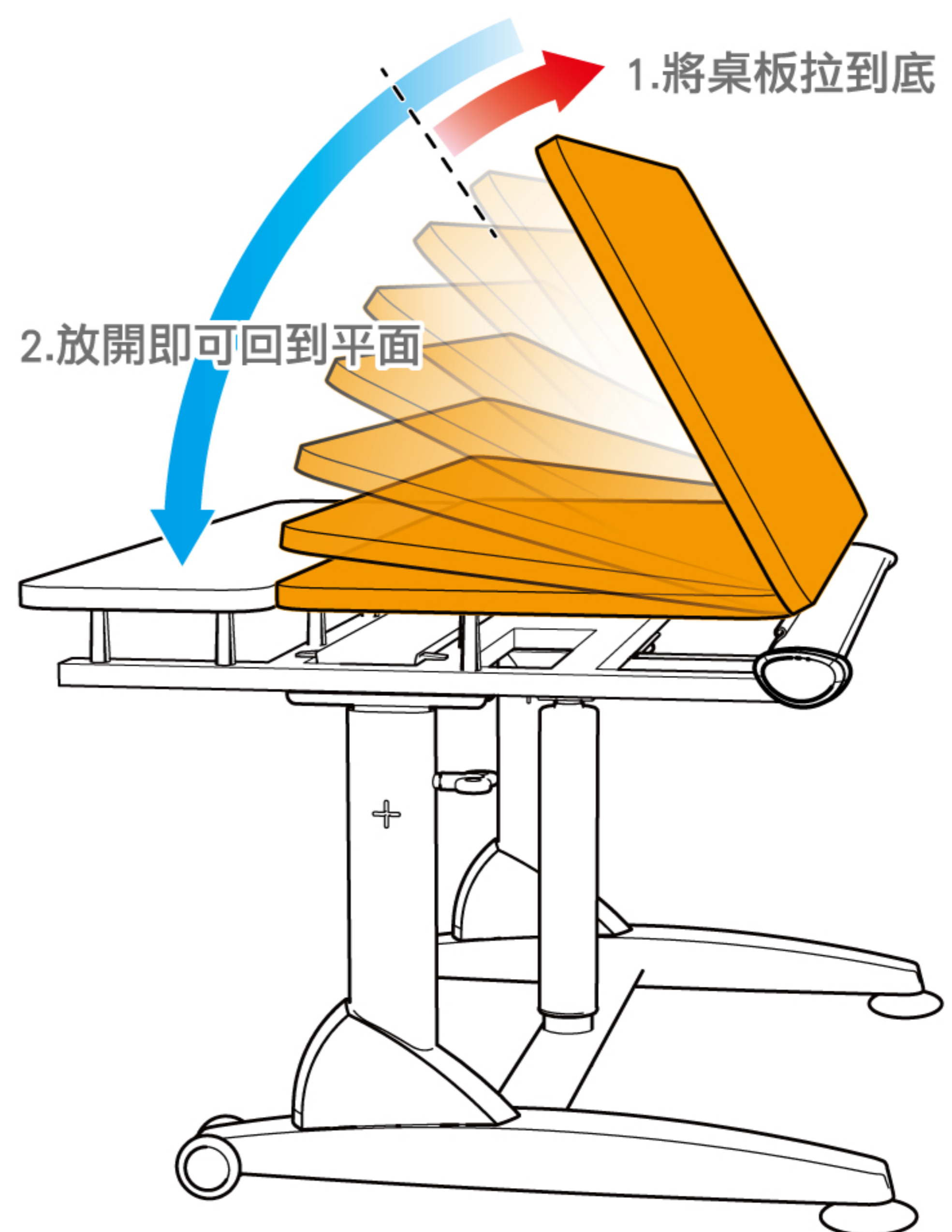
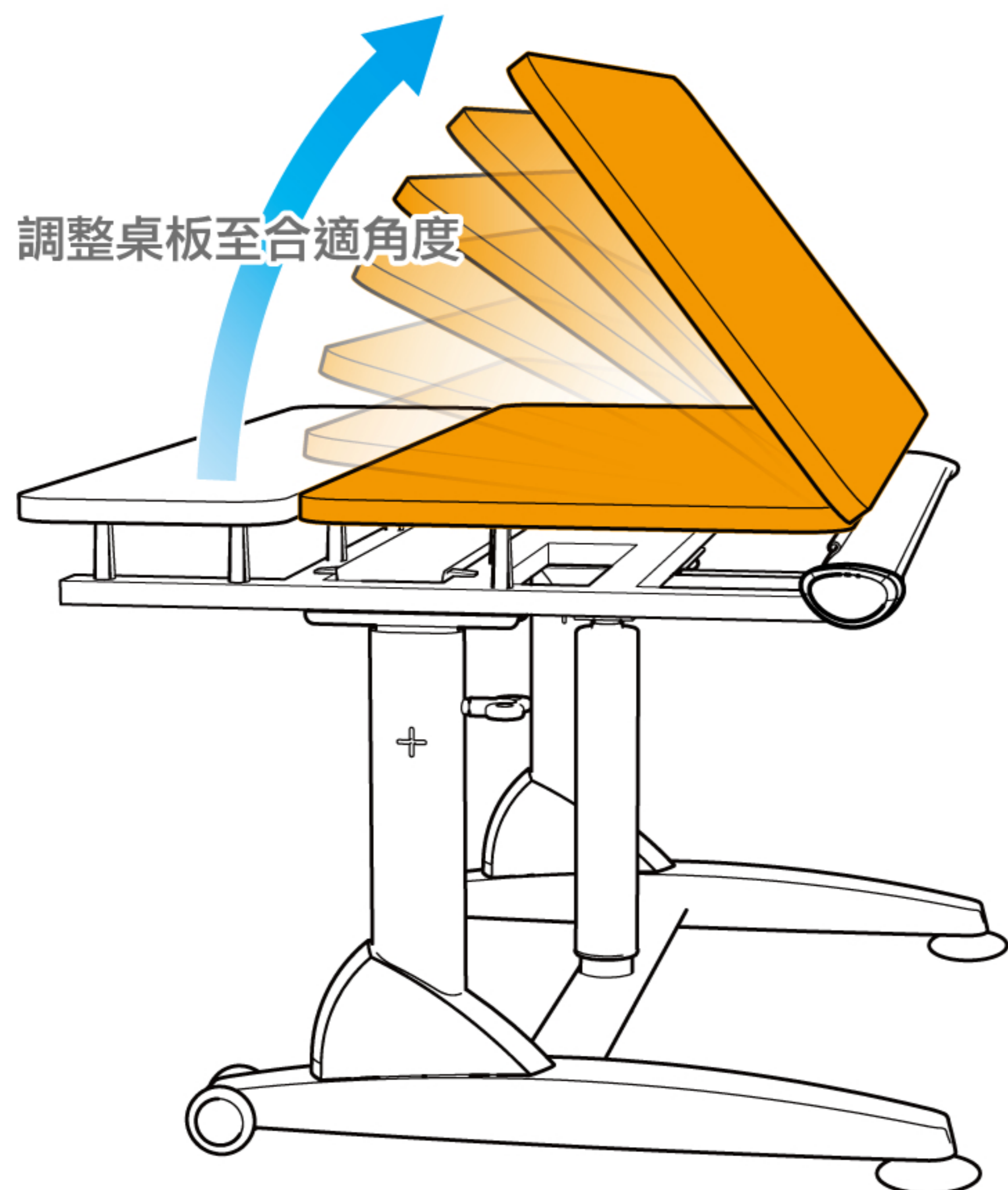

操作時請由家長陪同。



大將作中華地區客服專線

台灣地區

免費專線：0800-628 666

客服時間：08:00~19:00 (週一~週五)

Line ID：kid2youth1

客服Email：help@tctnano.com

大陸地區

官方客服：400 609 0809



官方微博



微信客服



官方網站

A. 什麼是品質保證10+5+1？

所有Kid2Youth 商品皆經過測試，於一般家庭日常生活下為標準，都能符合本公司對品質及耐用度的嚴格要求，並以不同的零組件區分為10年、5年、1年。每項產品及零件提供的品質保證及保固期限，自收貨日期或組裝日期起生效，購買時我們會有專員為您啟動線上保固。當原購買者轉售或轉讓該商品時，即為保固期限的終止期。顧客需要保固服務時，請出示原始購買發票或蓋有本公司店章之品質保證書，以本人或是出示身分證明文件，保固服務方可生效。故請妥善保存品質保證書及發票以利享有品質保證服務。

B. 品質保證涵蓋範圍

10年品質保證涵蓋範圍：Kid2Youth所採用之STABILUS氣壓棒本體。

5年品質保證涵蓋範圍：Kid2Youth所採用之主、副結構，如桌椅櫃本體及五金部。

1年品質保證涵蓋範圍：Kid2Youth所採用之損耗品結構，如書包、T5燈、PU輪腳、布面等。

(詳細品質保證服務條約內容請參閱D、E項)

C. 維修申報

1.於大將作官網www.kid2youth.com底部的『聯絡我們』中填寫表格描述故障原因並附上故障照片，我們會有專人與您聯絡。

2.我們將於3日內回覆您維修方式與所需時間(請參閱品質保證與服務內容)。

3.台灣以外地區維修申報與品質保固流程請洽當地經銷商。

D. 產品保固及品質保證服務內容

1.Kid2Youth收到維修單後3個工作天內會有專員立即為您服務。(僅限台灣地區)

2.總公司在收到維修單後將交給品保部門檢視商品損害情況，並主動聯繫您是否符合商品保固的條件。

3.若符合保固條件，我們將會另行告知維修時間，並以原廠零件進行維修或是以相同或同等級之商品替換。

4.若商品符合保固的條件，在不需支出特殊費用即可到府維修的狀況下，我們將負擔維修、替換零件、服務人員的費用工資。

5.如果商品不符合保固條件，判定因人為因素造成損壞，大將作將主動聯繫並同時報價詢問維修意願。

6.產品送修運費由買家承擔，如判定非人為因素損壞，回寄的運費由大將作承擔，如判定為人為因素損壞，回寄的運費將由買家承擔。

7.商品保固不適用於未經Kid2Youth總公司授權的維修工作。

8.原商品零件一經替換，該原商品零件所有權即為Kid2Youth所有。

9.如果Kid2Youth不再銷售該商品，我們將提供適合的替代商品為您更換。

10.台灣以外地區維修申報與品質保固流程請洽當地經銷商。

E. 哪些狀況下無法得到產品保固及品質保證

1.產品保固不包含正常性損耗如碰撞，切割，或不當人為操作等。

2.商品若放置於室外或潮濕的環境，不適用於本商品保固。

3.商品保固不適用於自行拆除、搬移或修補商品而造成的毀損。

4.商品保固不適用於天災、人為或意外事件所造成的毀壞。

5.未按操作使用說明所造成之損壞即視為人為因素損害。

6.產品保固不適用於表面因時間引起的色澤差異。

7.展示品及原廠特賣，所購買的商品不在保固範圍內。

8.品質保證只涵蓋原始購買人，權益不得轉讓。

9.品質保證書內未加蓋本公司店章或無法提示購買證明，如發票者。

10.Kid2Youth保留修正此品質保證條款與細則之權利。

F. 產品使用與保養指南

1.操作產品前應先詳細閱讀操作手冊與產品說明書。

2.不自行拆裝產品結構避免產品損壞而失去品質保證服務。

3.應定期檢查關節部件並施以潤滑。

4.氣壓結構產品應定期解鎖並調整高低數次以保持順暢度。

5.於使用數週後用包裝內專業工具將螺絲鎖緊並逐年檢查螺絲緊度數次。

6.使用拉鍊時請一手握住拉鍊起始點一手握住拉鍊扣，順著拉鍊方向移動。

如有卡住情形，請避免用力拉扯，反方向移動後再順著拉鍊方向移動即可。

7.清潔任何表面不可使用侵蝕性清潔劑或粗糙表面物品擦拭，請用40度以下溫水與清潔劑沾水擦拭，並隨後用乾布擦乾，保持乾燥(金屬活動結構請定期施加潤滑劑保養，勿用清水擦拭)。

疑難排除

剛組裝好就無法順利調整升降？

請先檢查桌面是否放物品？是否只放在某一個地方（重心會偏離）？

若是時，請先將桌面清空或將東西移到較中間位子，讓重心移至中間，桌面較呈水平，即可正常調整，再將物品移至原來位子即可。

若無時，請先使用水平尺或圓形物體檢查地面與桌面是否呈水平狀態。

若未呈水平，請將所有螺絲鬆開一半，然後做升降的動作，2~3次後壓到底，鎖緊即可正常升降；若已呈水平狀卻無法升降，請填寫維修單，傳回公司，公司將會盡快處理。

桌面傾斜至一定角度時而無法固定時？

請使用老虎鉗在無法固定處稍微夾緊即可。如有異聲，請加潤滑油及可消除聲音。

使用一段時間桌子無法升降？

請先檢查桌面是否放物品？是否只放在某一個地方？（重心會偏離）？

若是時，請先將桌面清空或將物品移到較中間位子，讓重心移至中間。

若無時，將桌面先往下調整再用手往上支撐，如此循環幾次，即可正常調整；若桌子已在最低點，則直接用手往上撐。調整至所需要高度鎖緊把手後，再將物品移至原來位子即可。



G2C+/G6+/G6C+ Assembly Instruction



- 4 years old up only.
- Assembled by adult.
- Parents' presence with junior users is suggested.

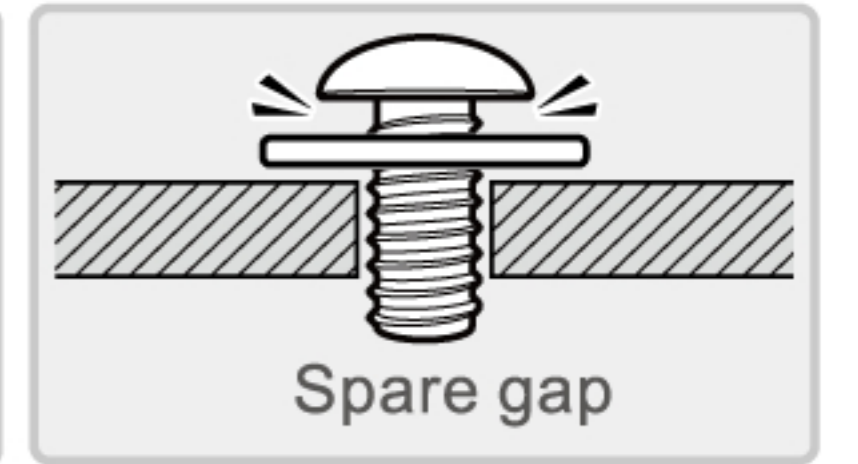
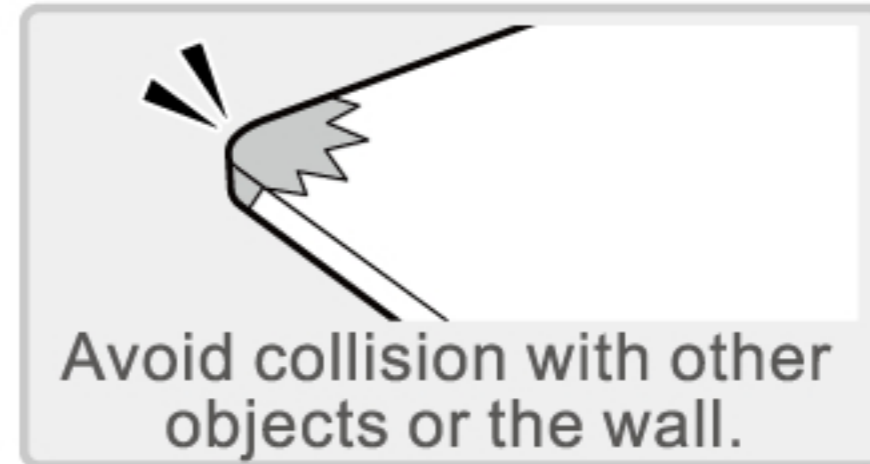

1 Top

G2C+ | XXS
XS

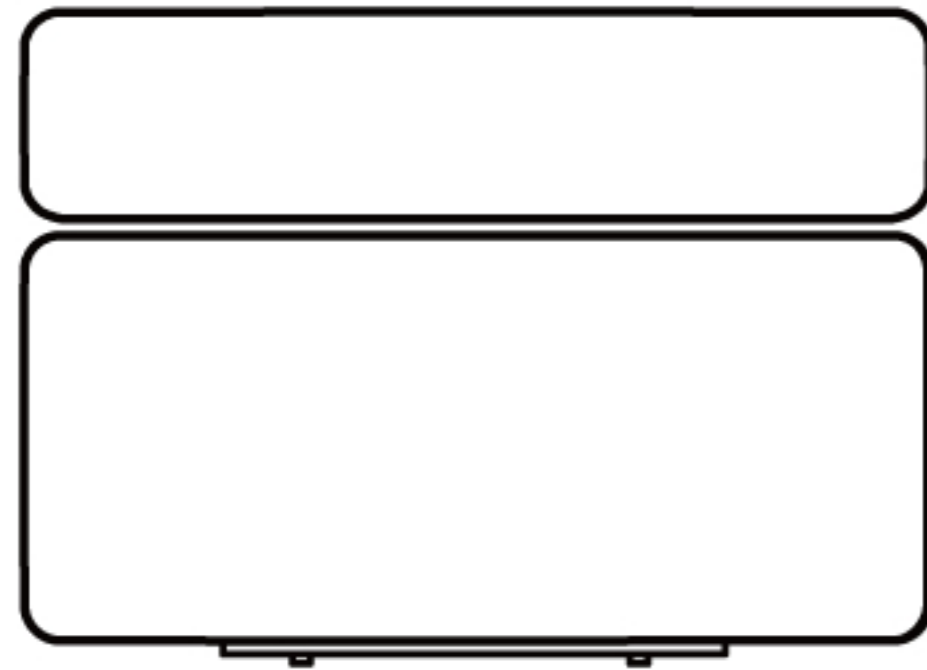

G6+ | XS
S

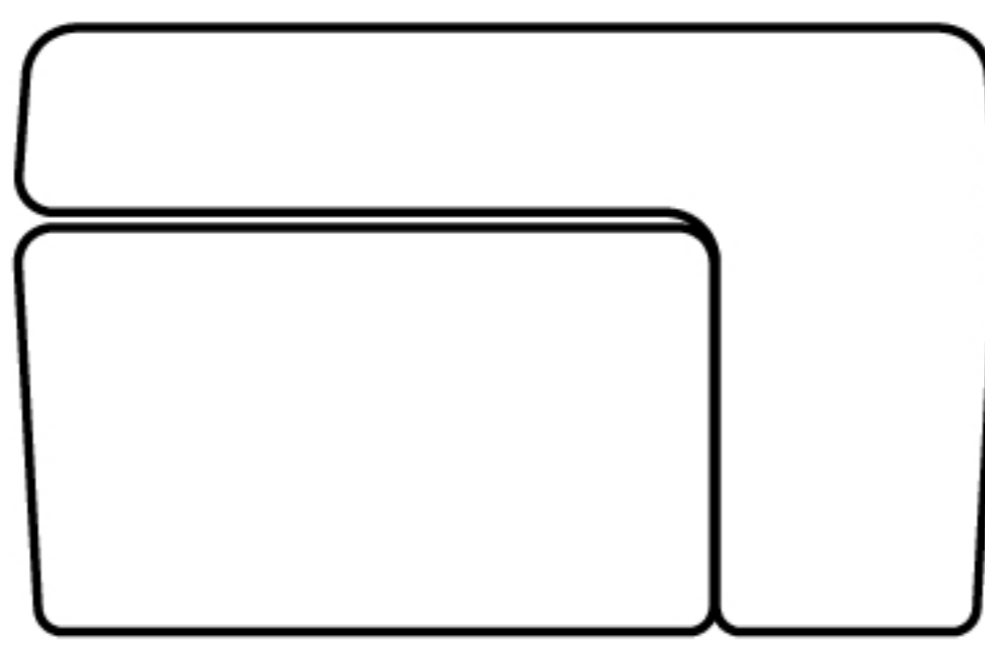

G6C+ | XS
S

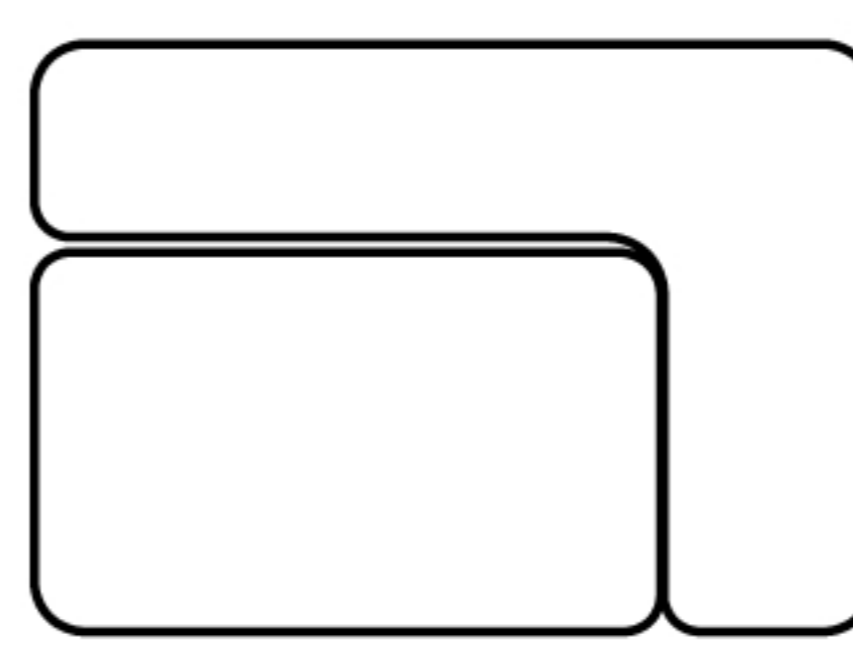

2 Oil buffer

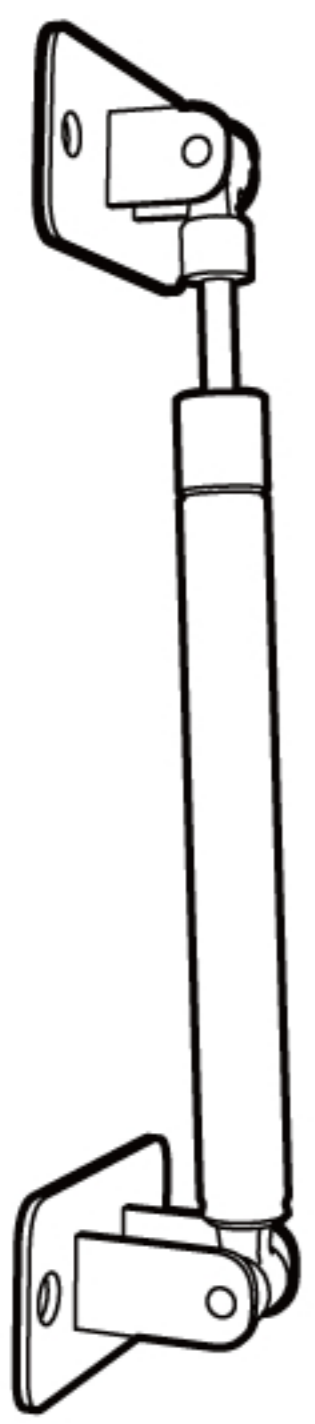

3 Leg

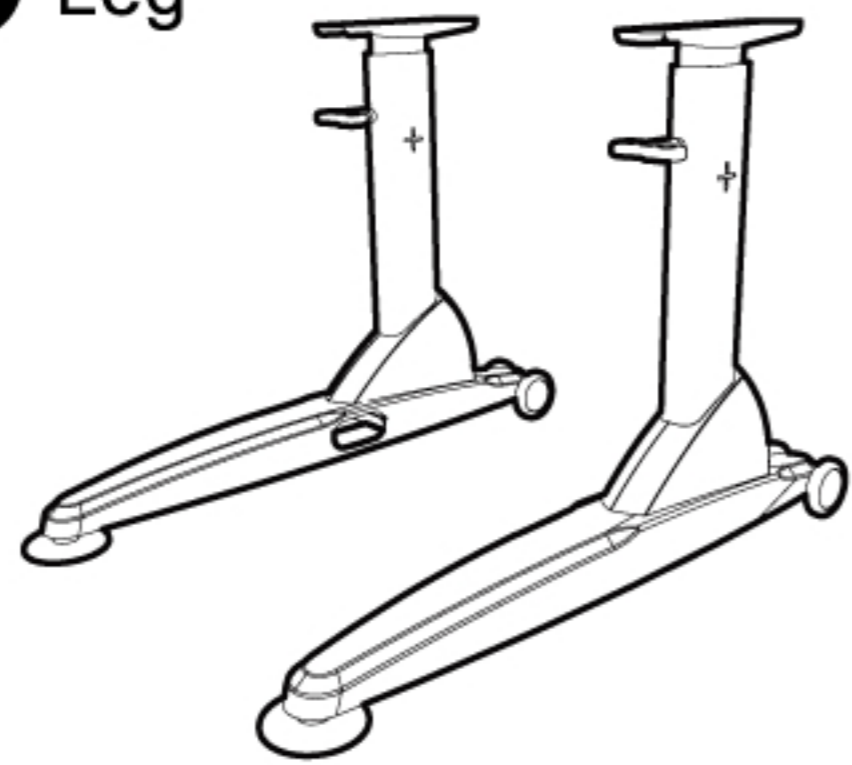

4 Low horizontal shaft

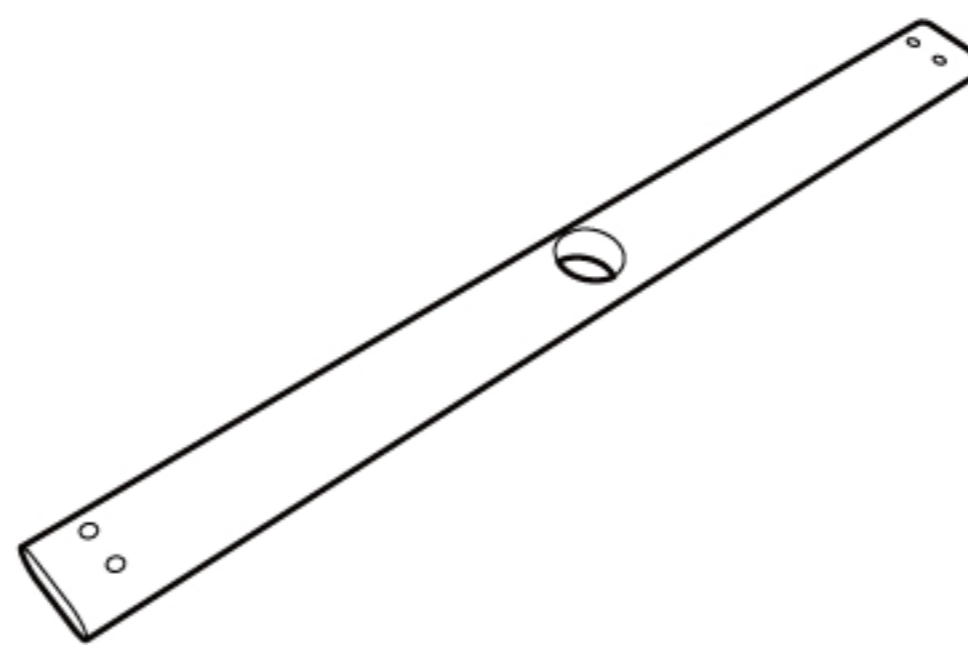

5 Mounting Plate

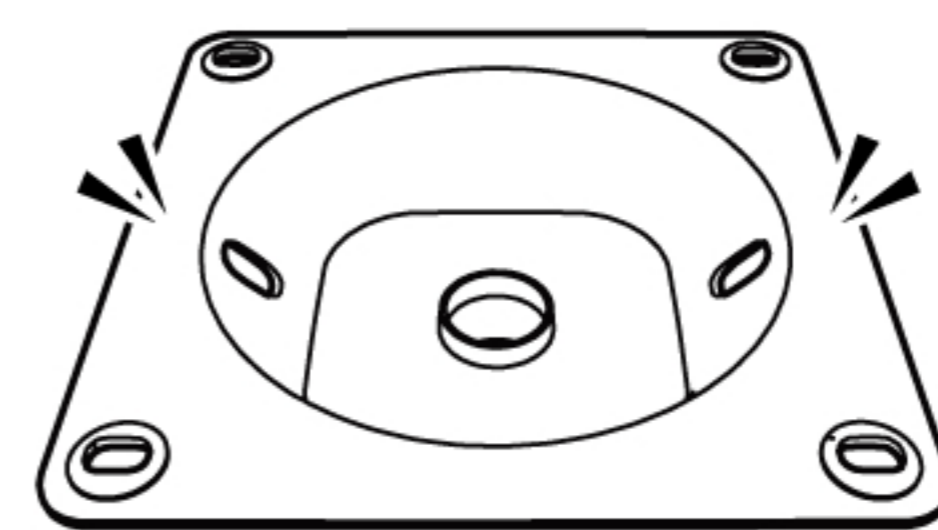

6 Gas lift

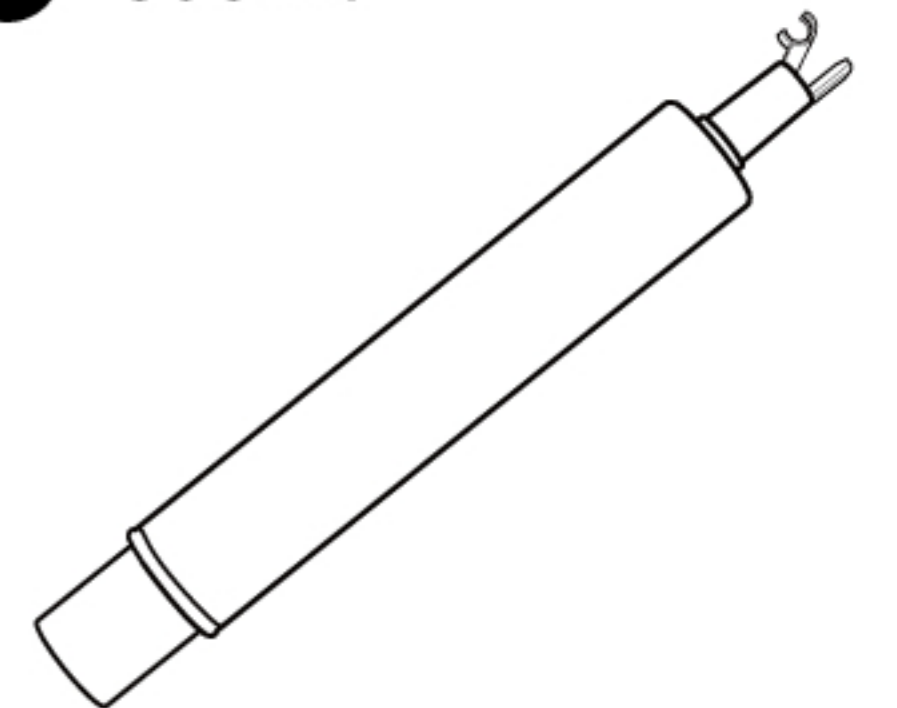

7 Wire controller

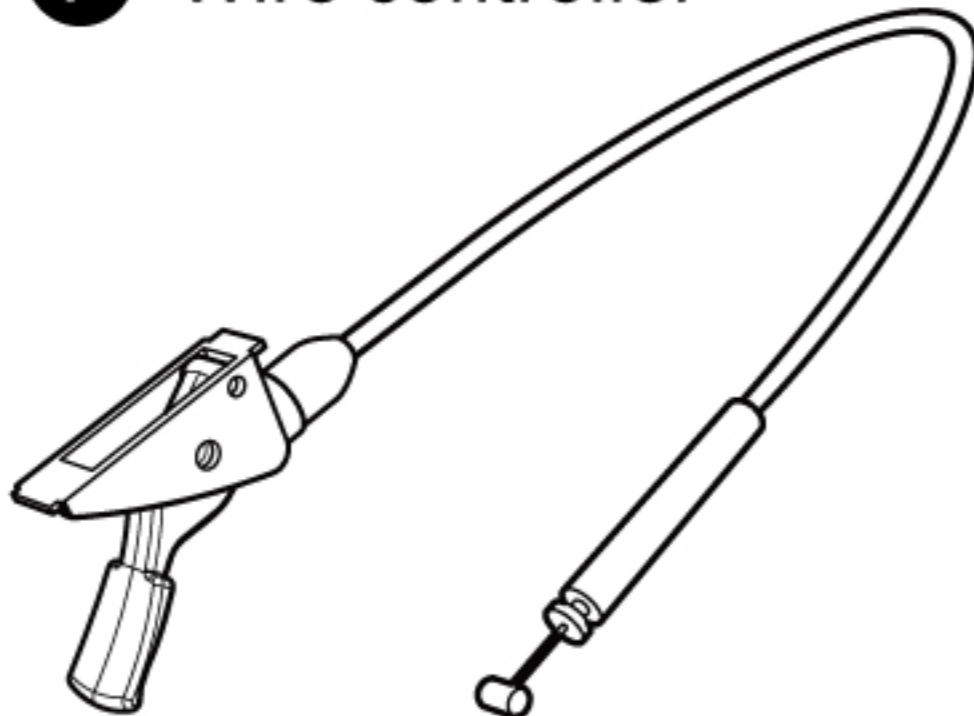

8 S Cable organizer

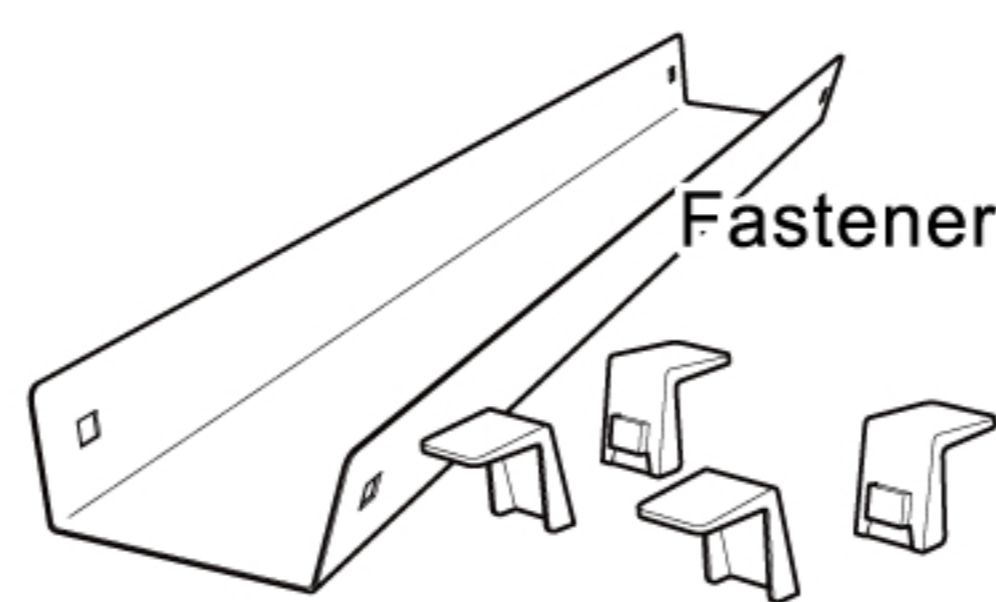

9 Wrist rest ruler

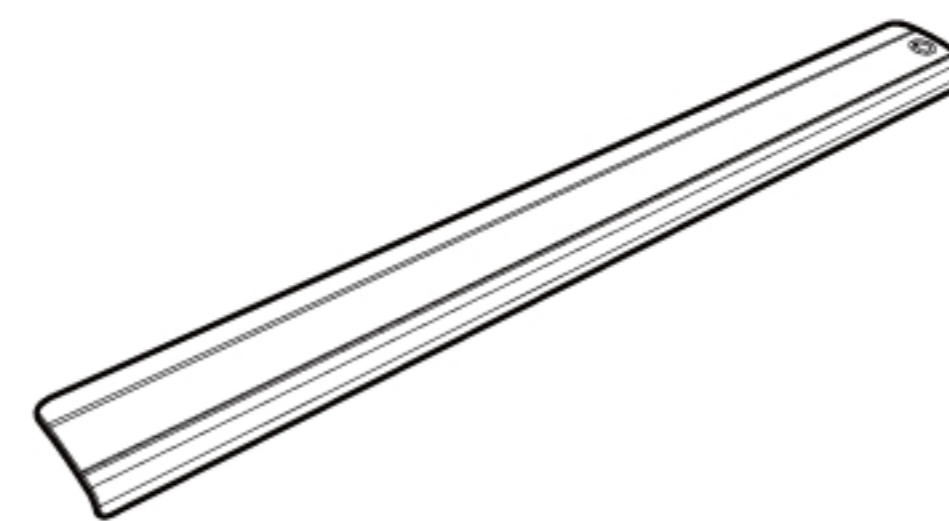

Parts Kit



Hex key NO.4

A Screws X 4

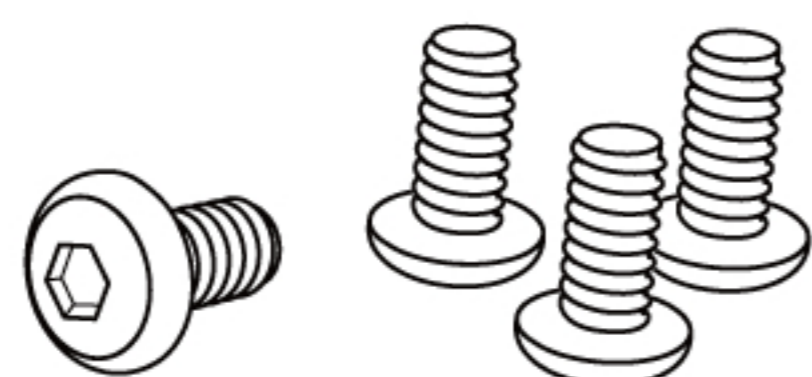

1/4*15mm

A Screws X 4
B washers X 4



1/4*15mm

C Screws X 4
D washers X 4

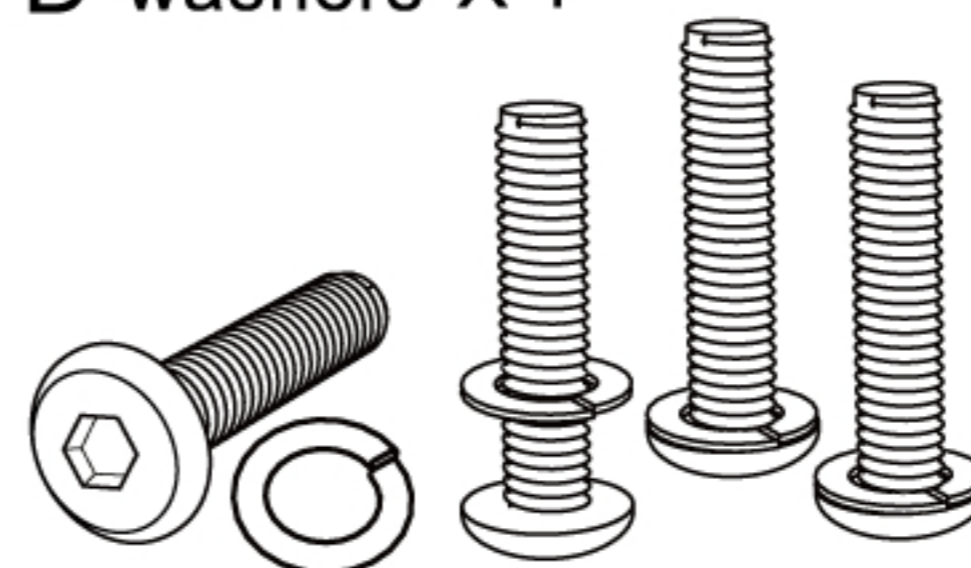

M8*38mm

1

Pull out supplies tray first and align Oil Buffer 2 with screw holes then fasten Screws H & E tightly.

Note directions

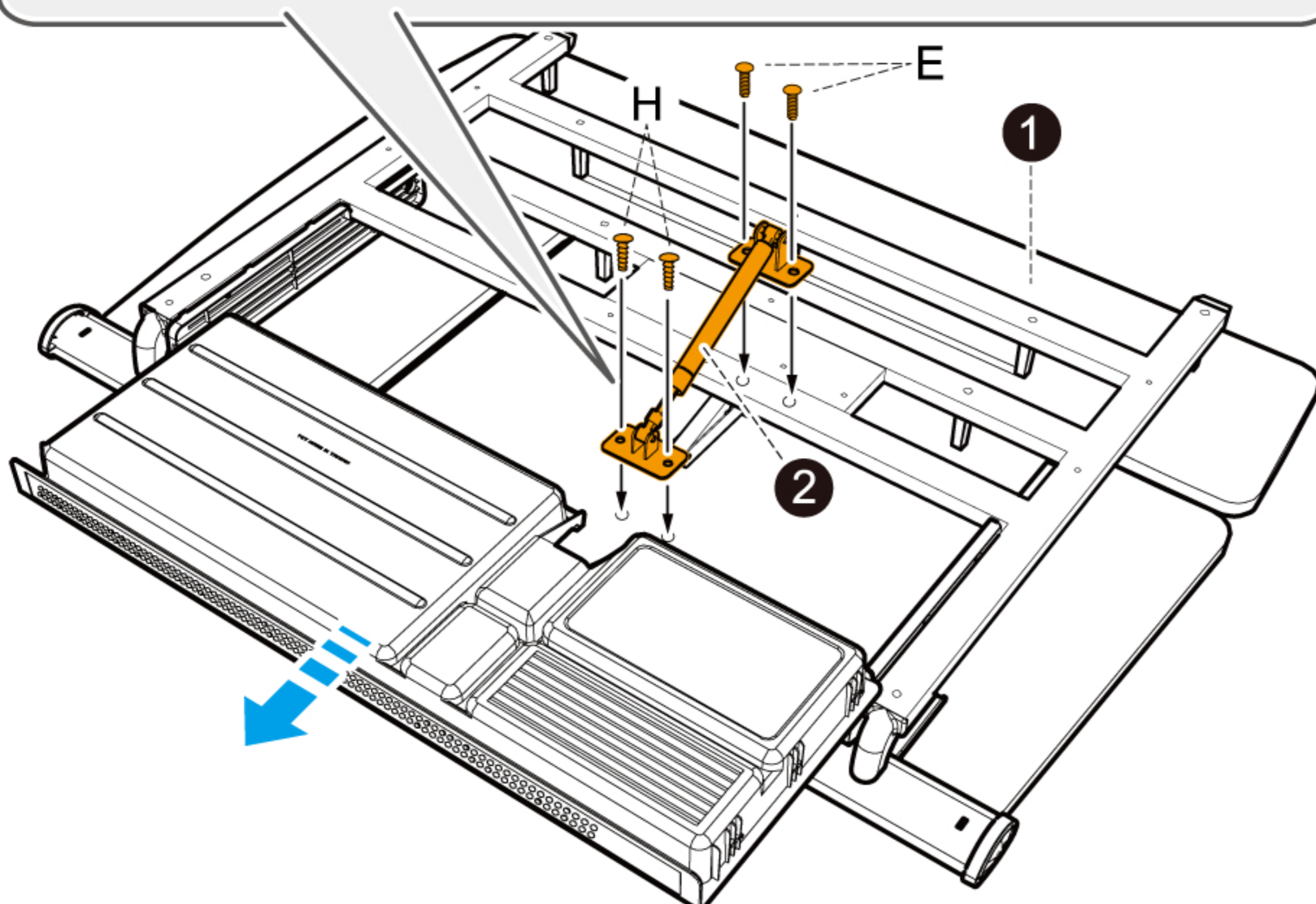
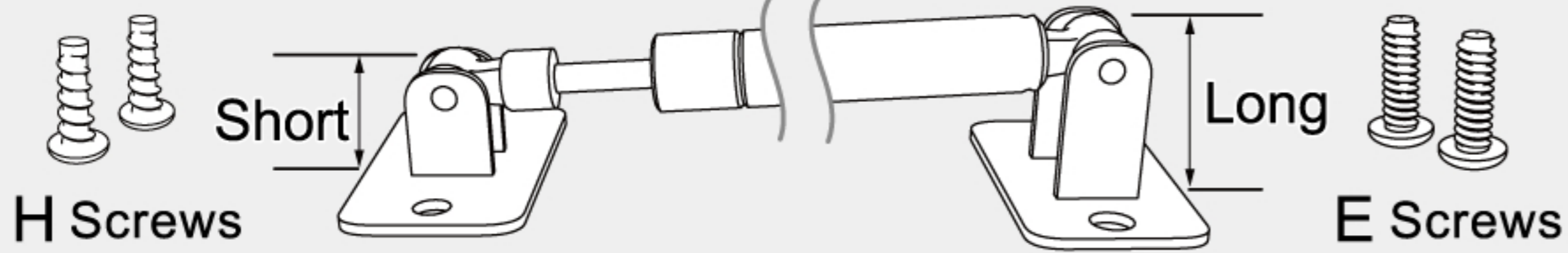

2

Insert Mounting Plate 5 to Gas Lift 6, and install Wire Controller 7 to Mounting Plate 5

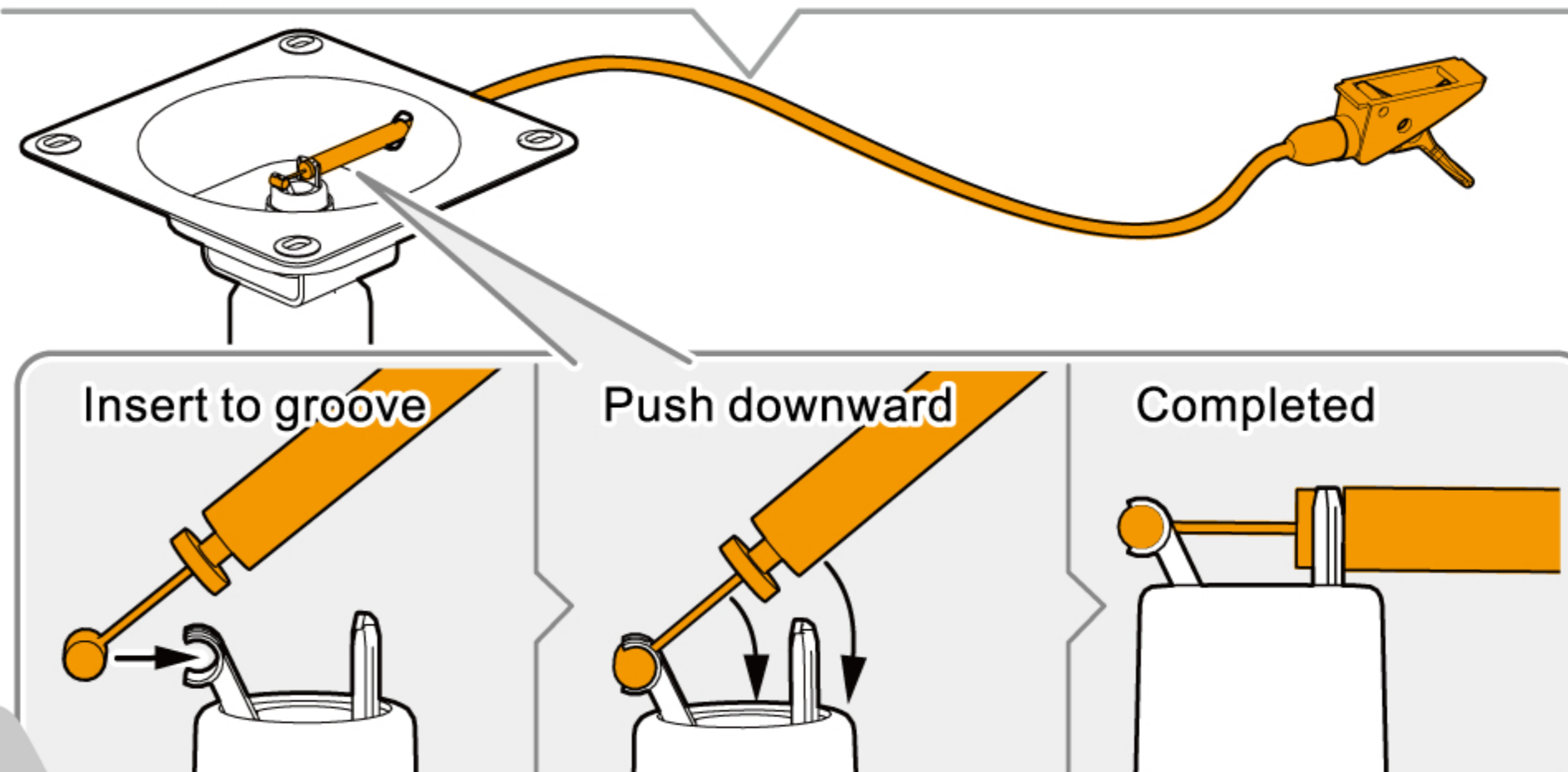
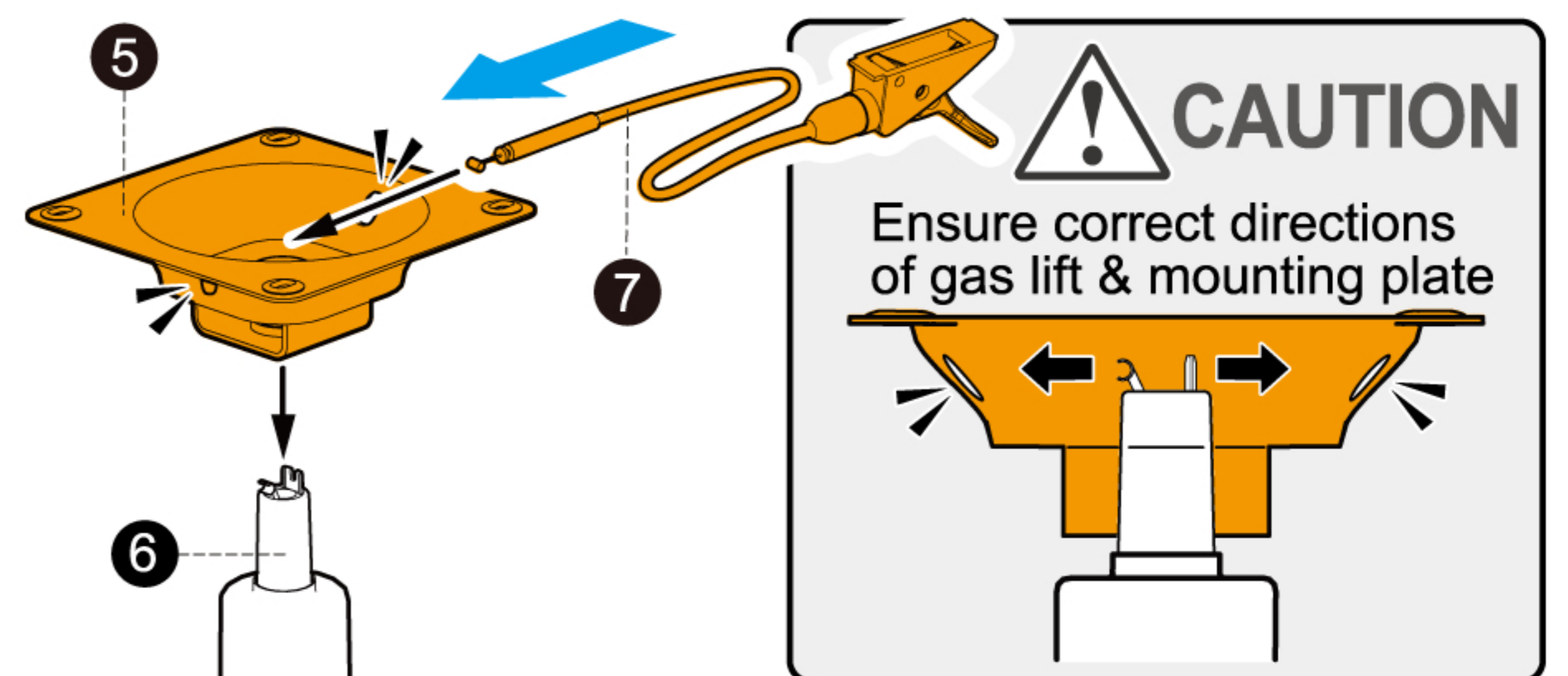

3 Fasten up Screws A / B in order

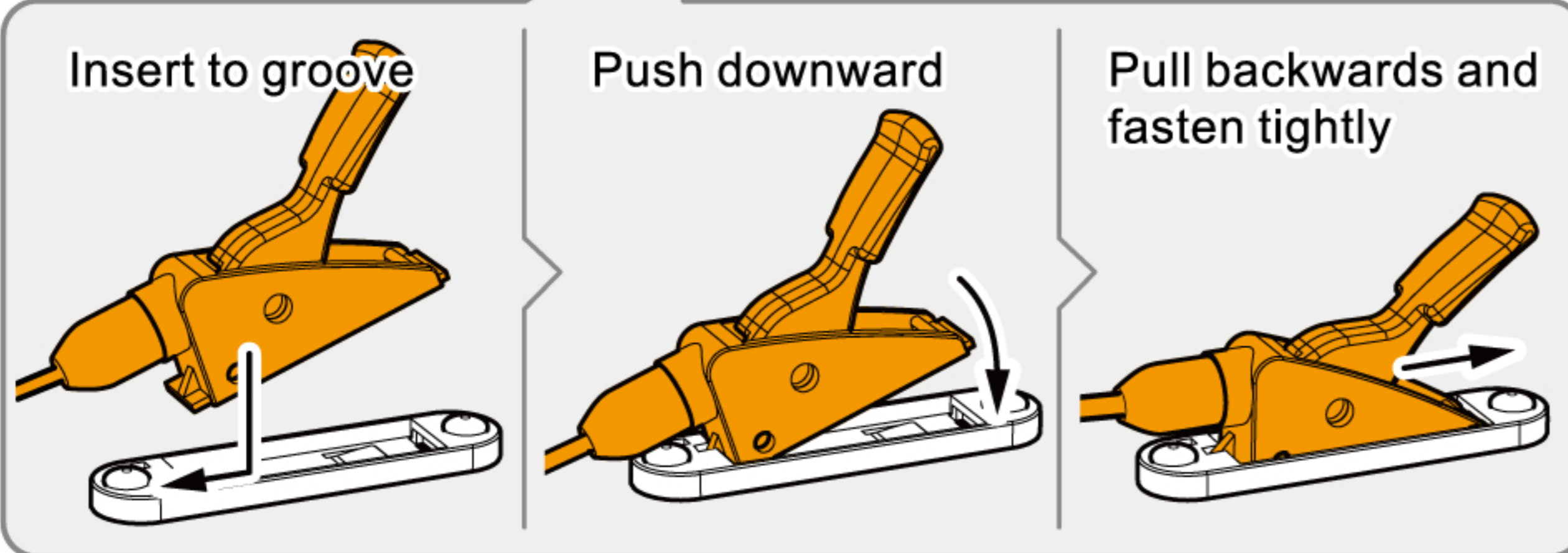
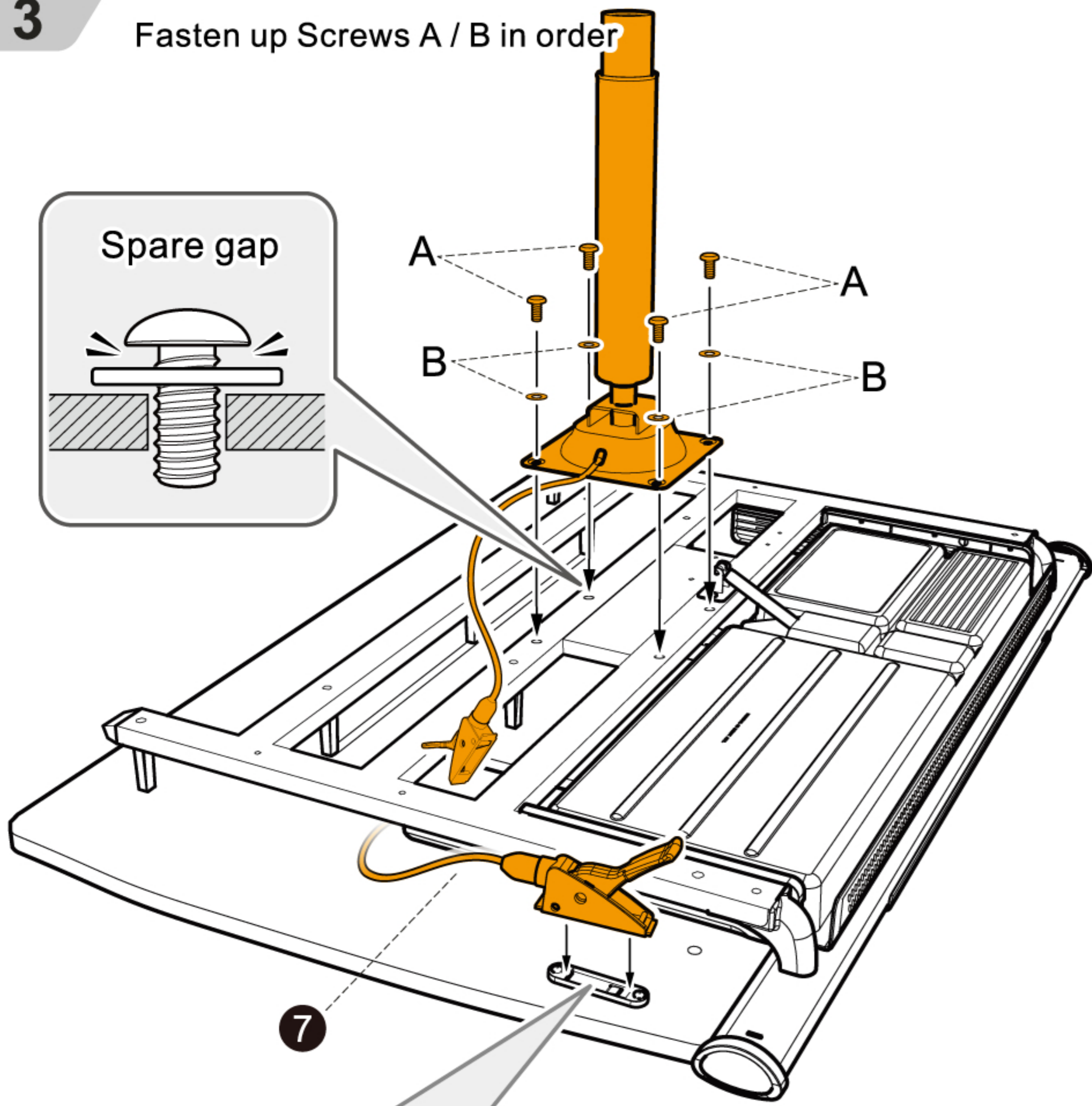
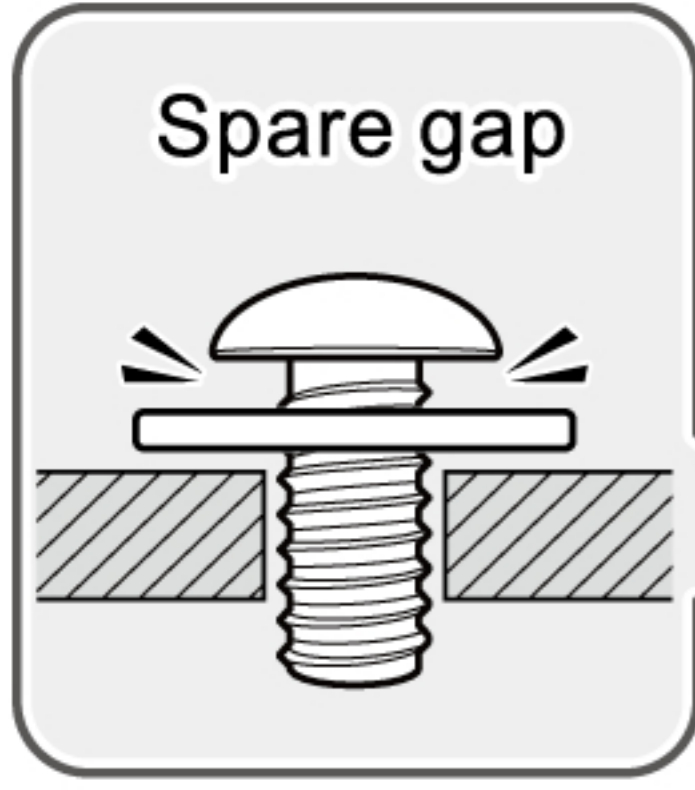

4

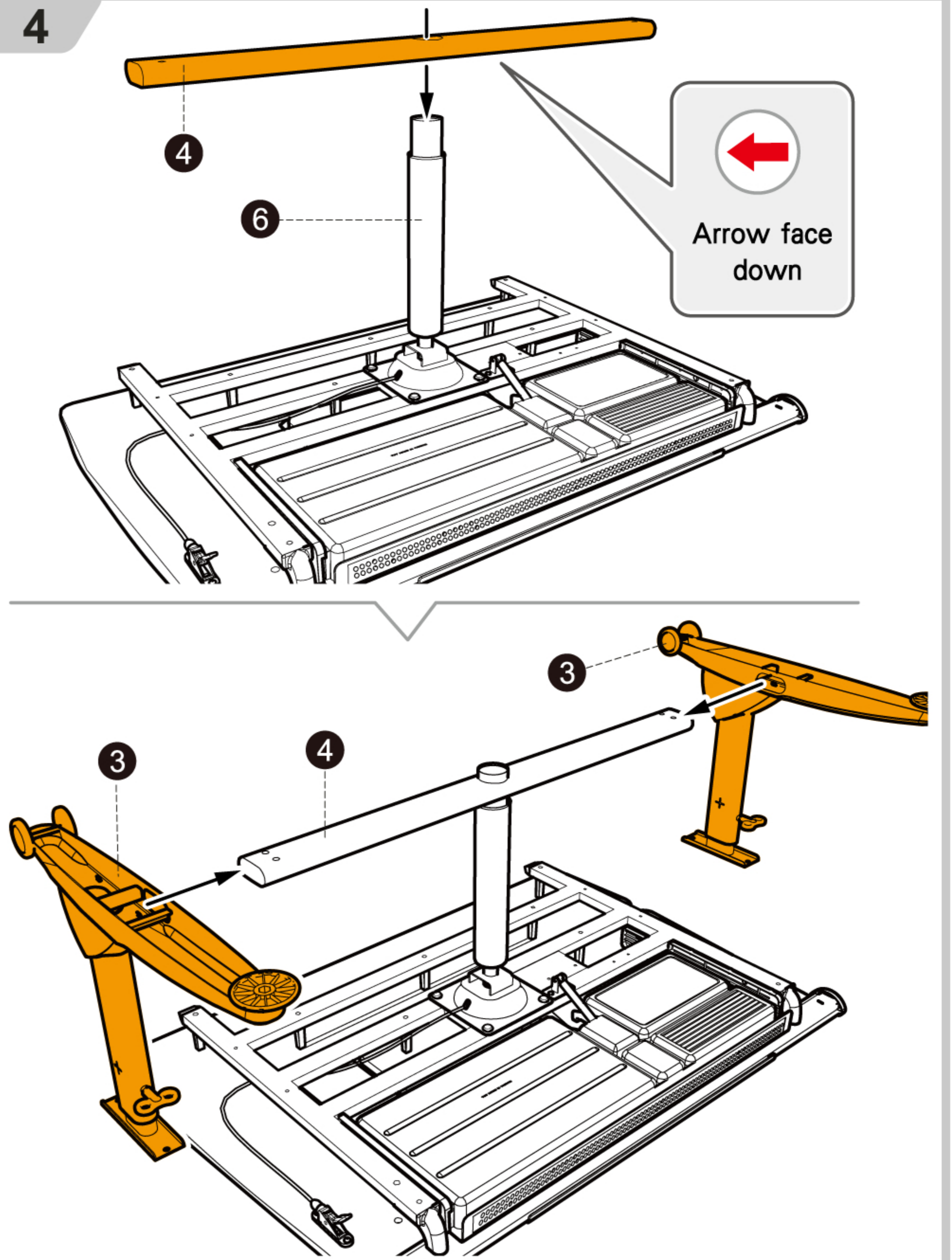

5 Check up assembly tightness



Check up level of legs

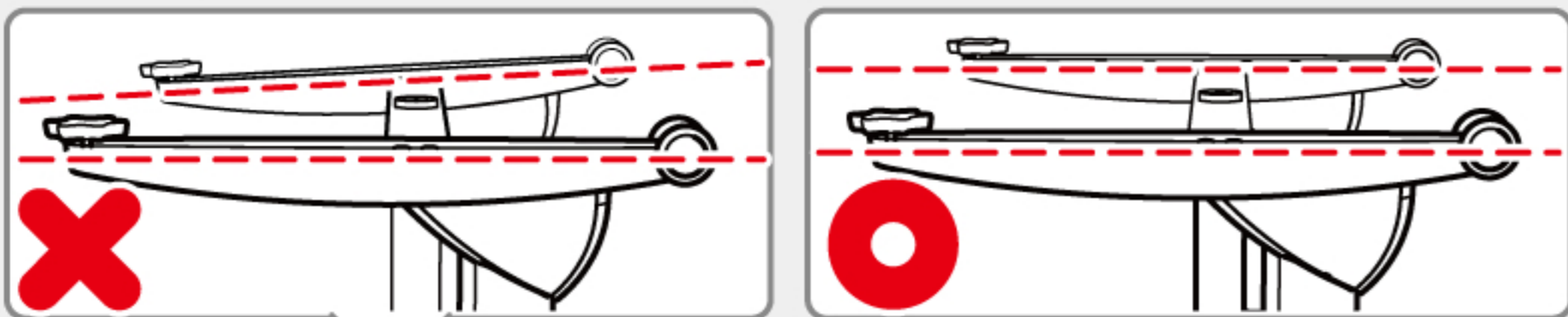

If the desk leg can not level

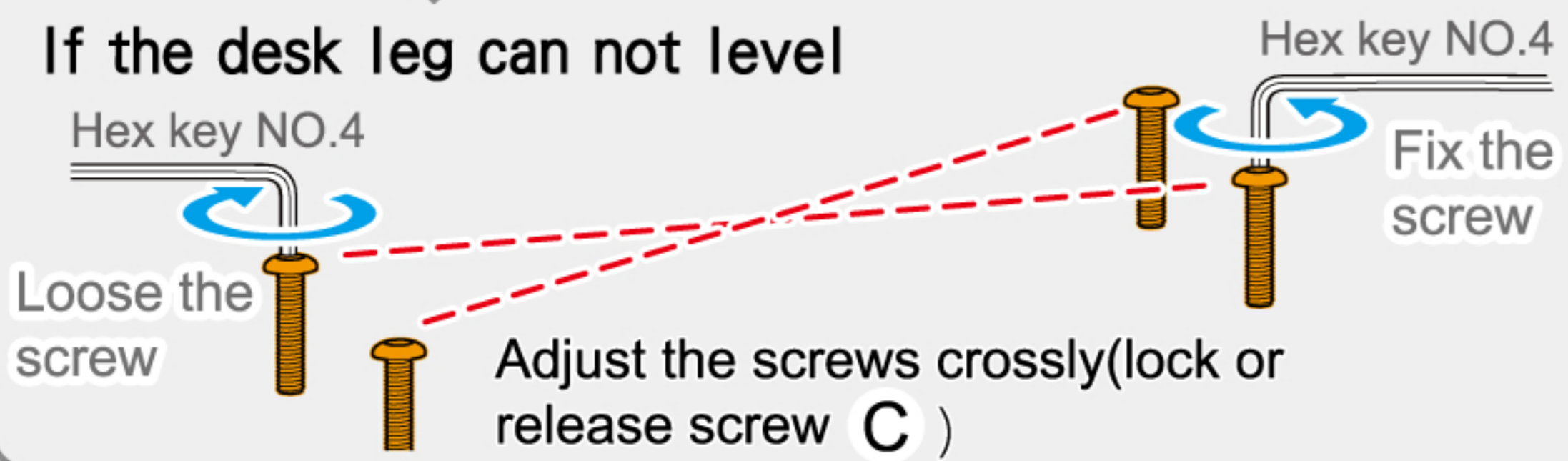

Fasten up Screws C / D in order

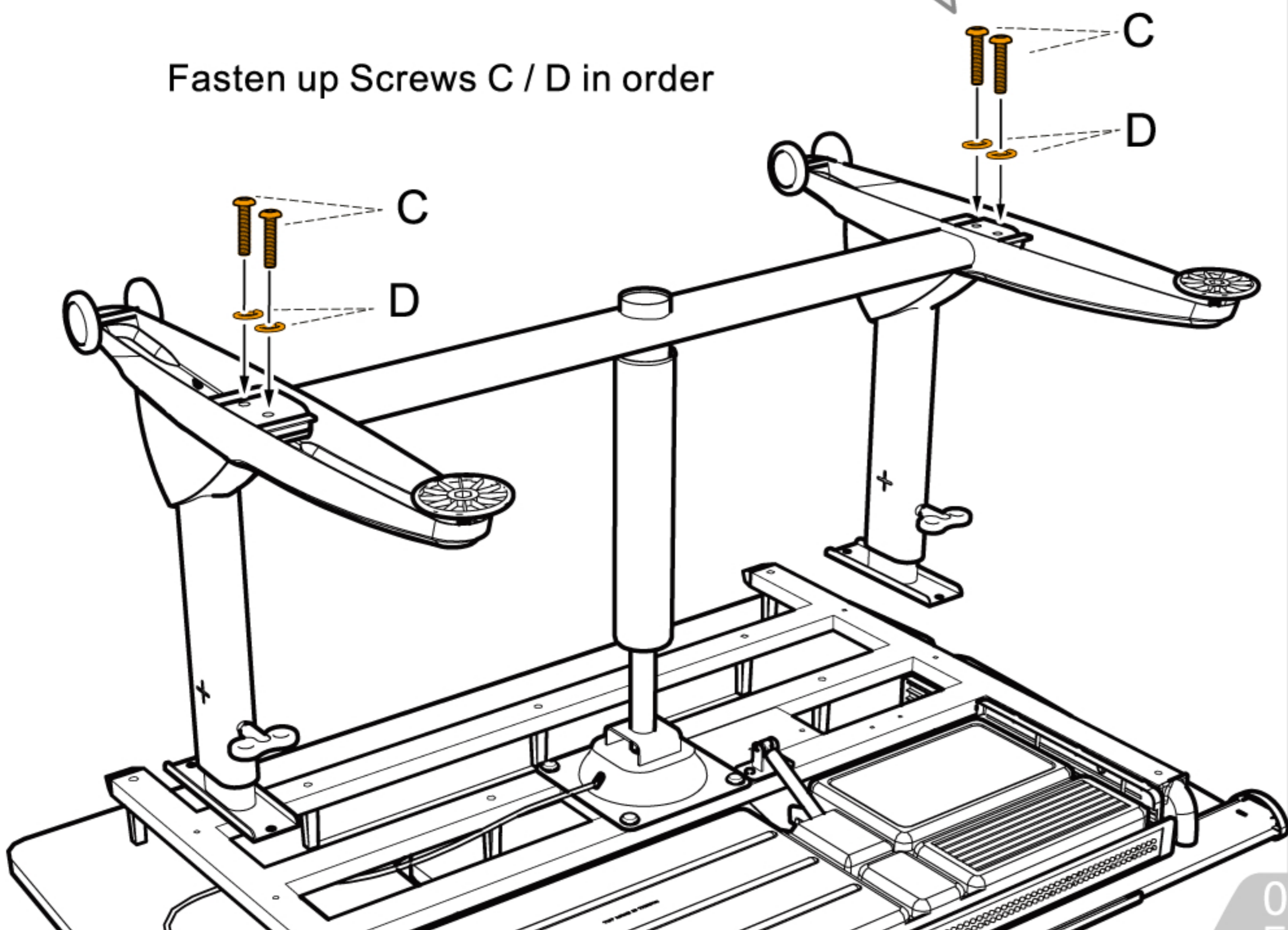

6

Step1. Release knobs.
Step2. Hold up inner tubes avoid falling.

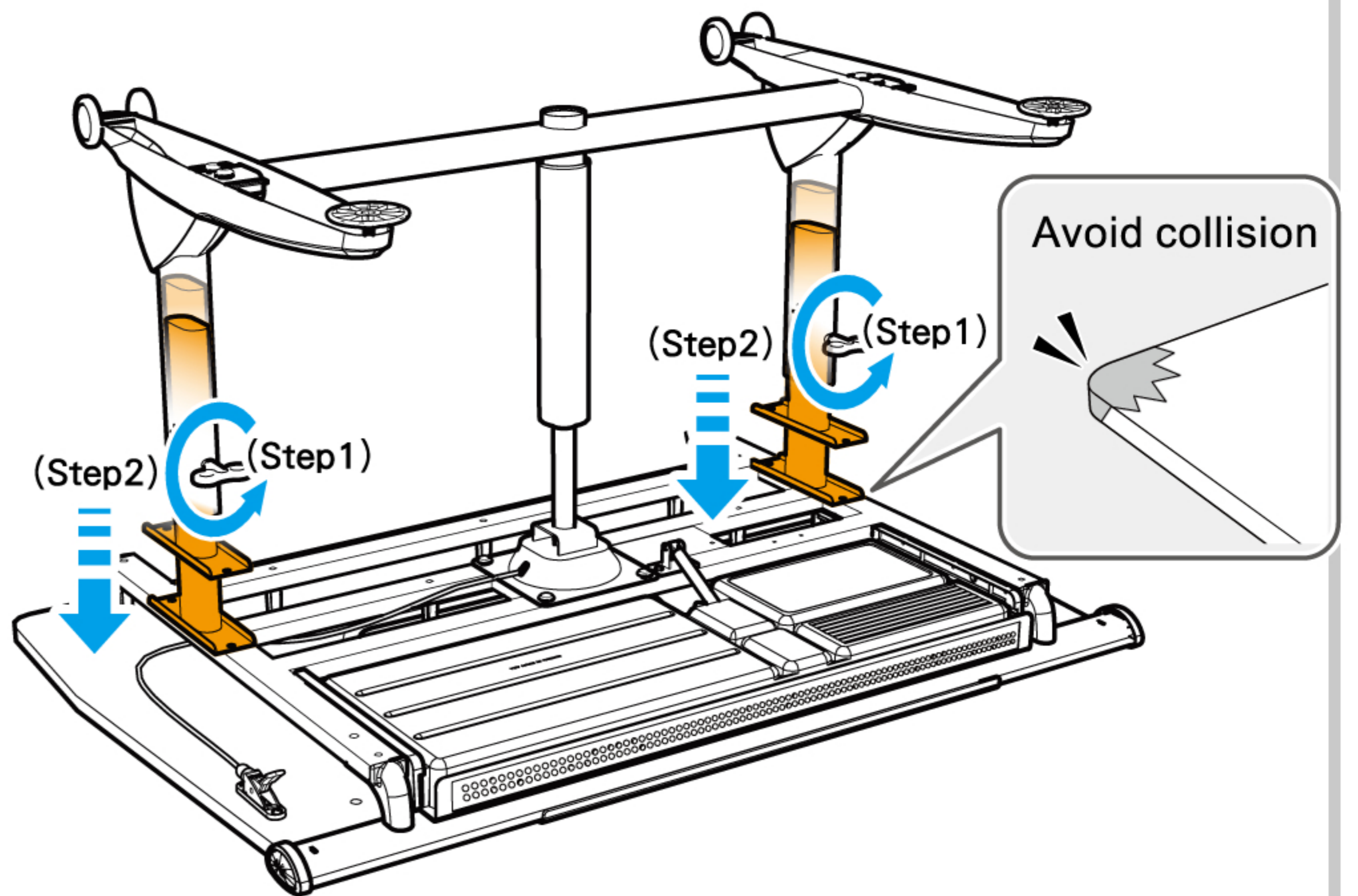

Loosely fasten Screw A

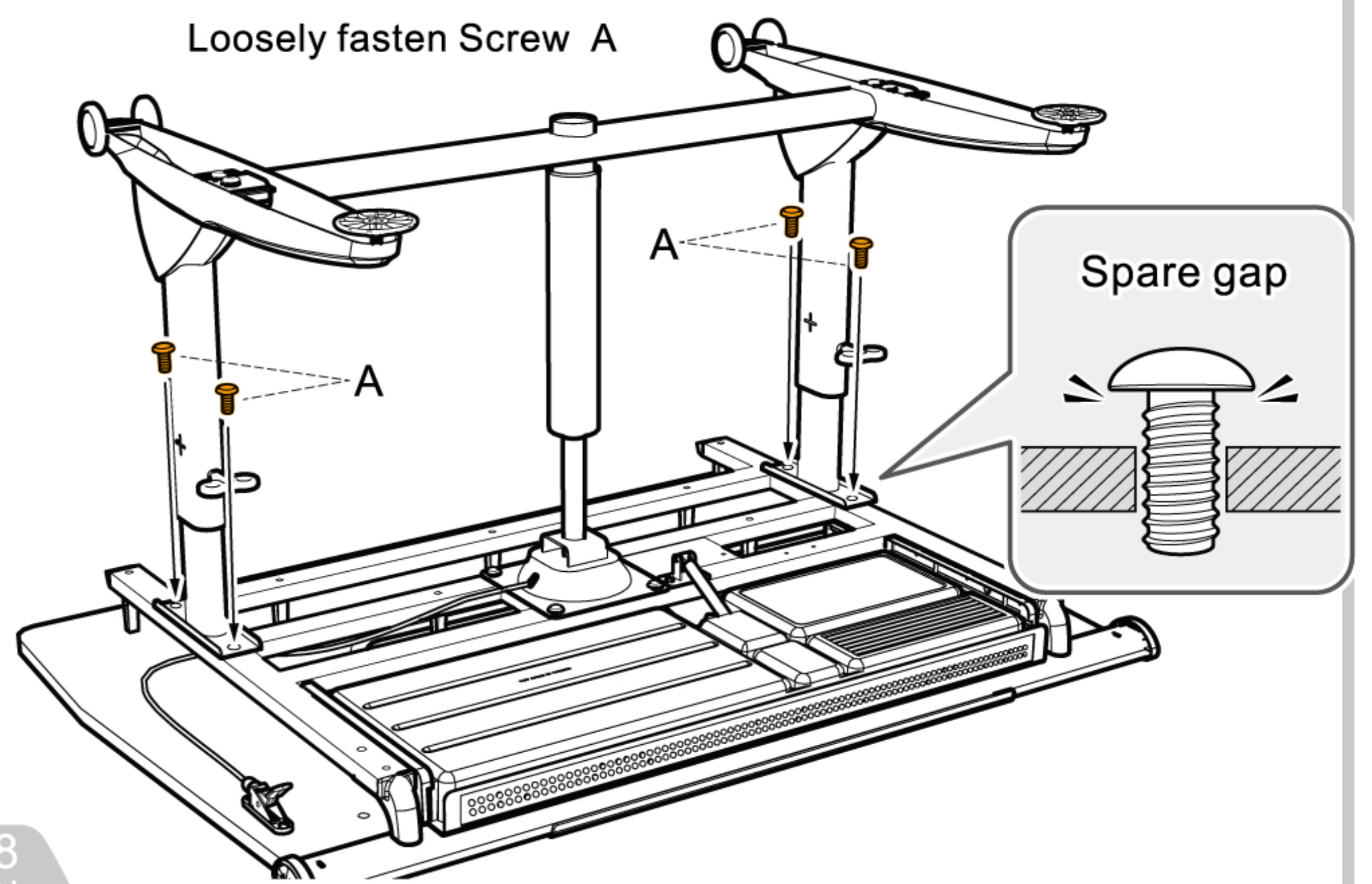

7 Step1. Pull the wire control, repeat going up and down the till desk runs smoothly.
 Step2. Tight up all half-fasten screws.

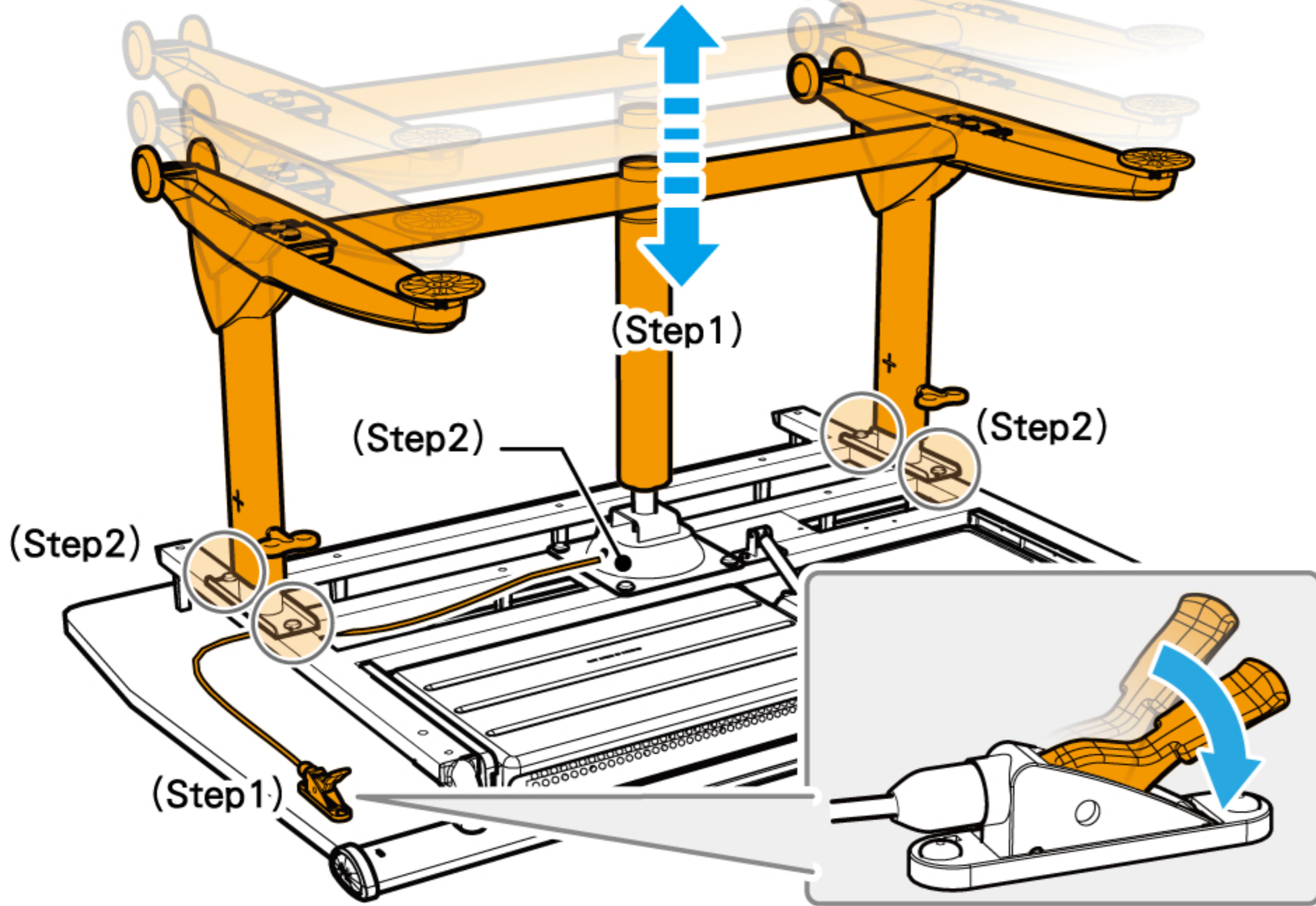

8

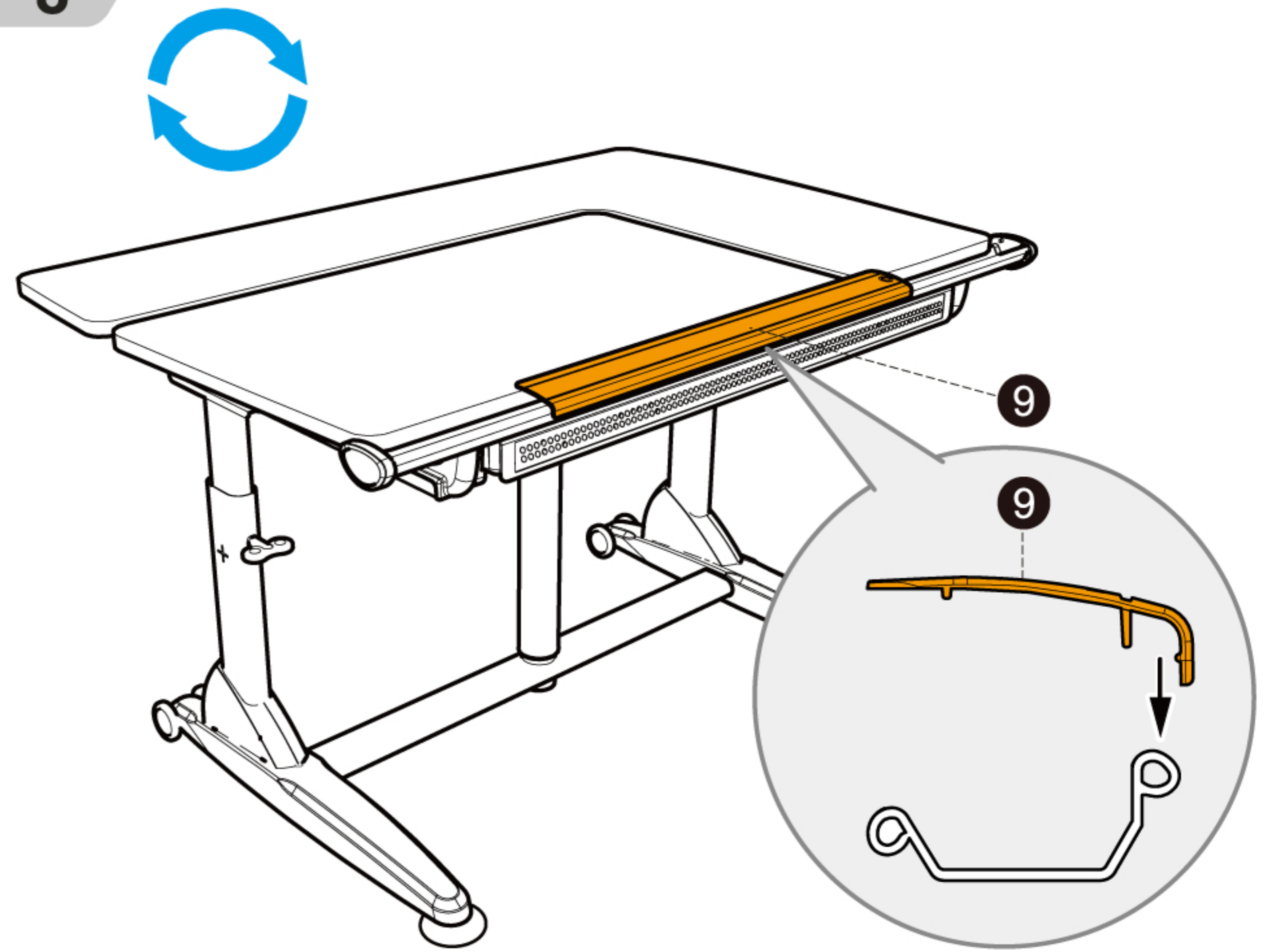

Attention

Do not distribute the loading weight on desktop unbalanced.

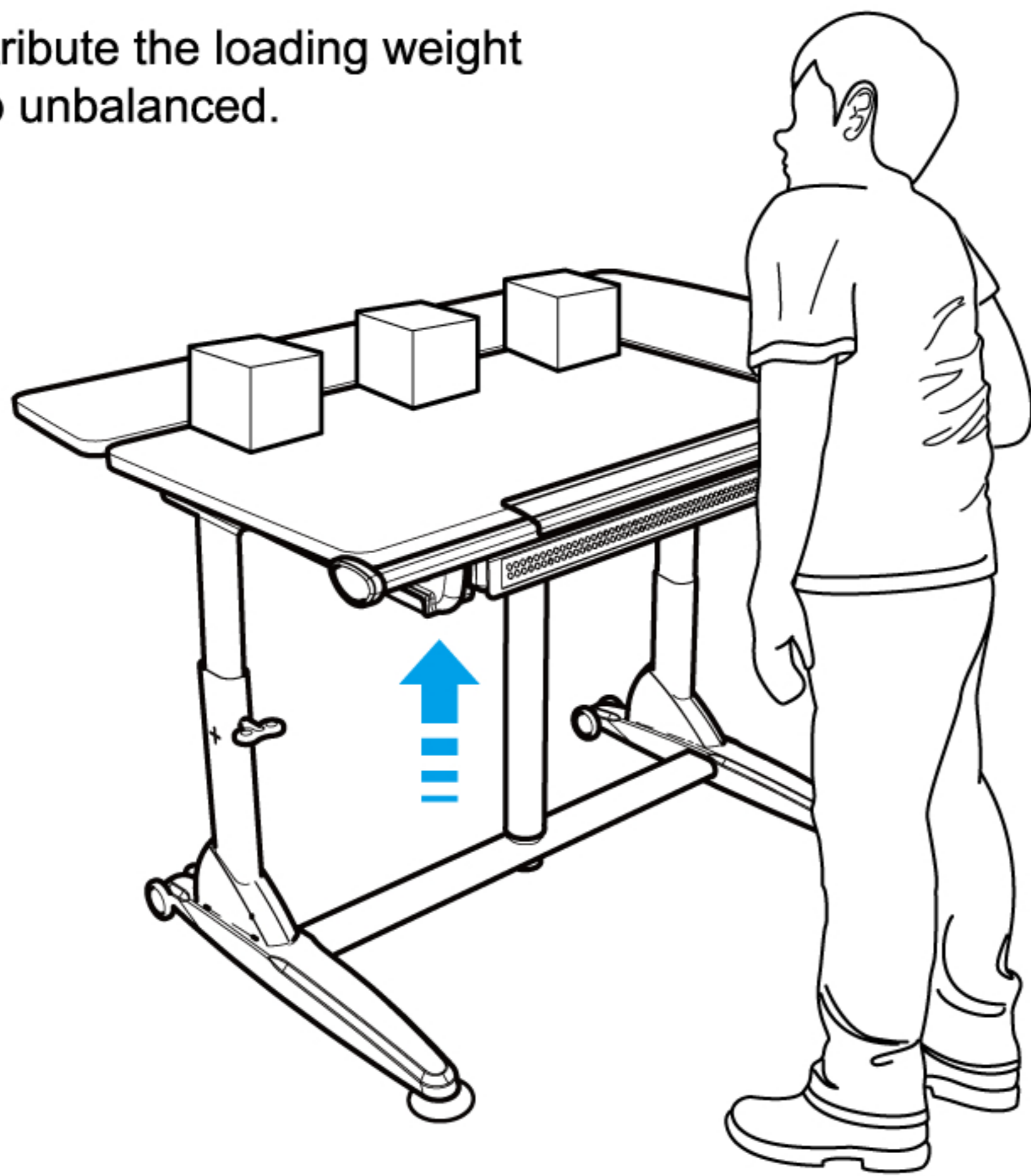

Adjust height with hands if desktop weight is overloaded.

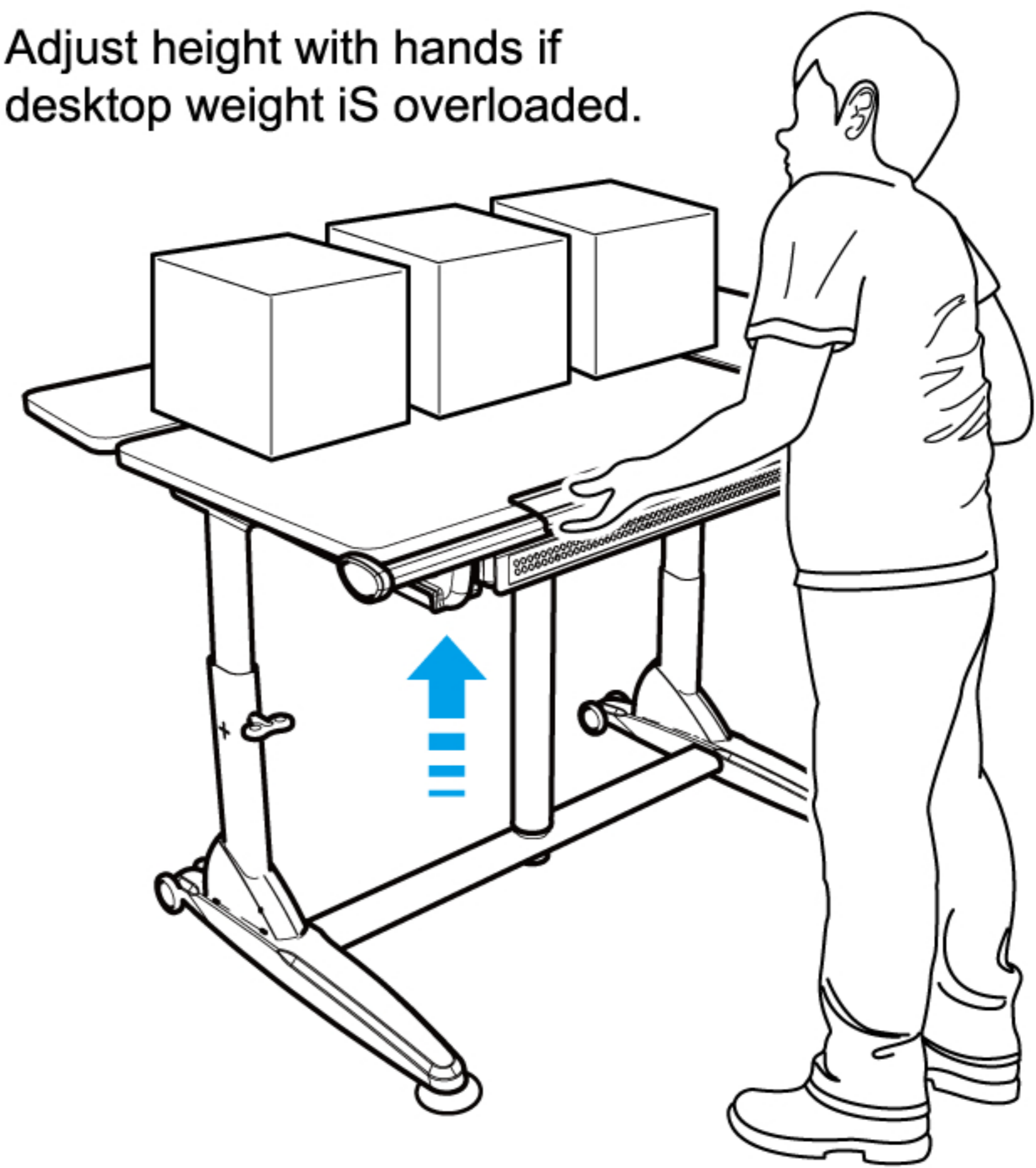

Instruction

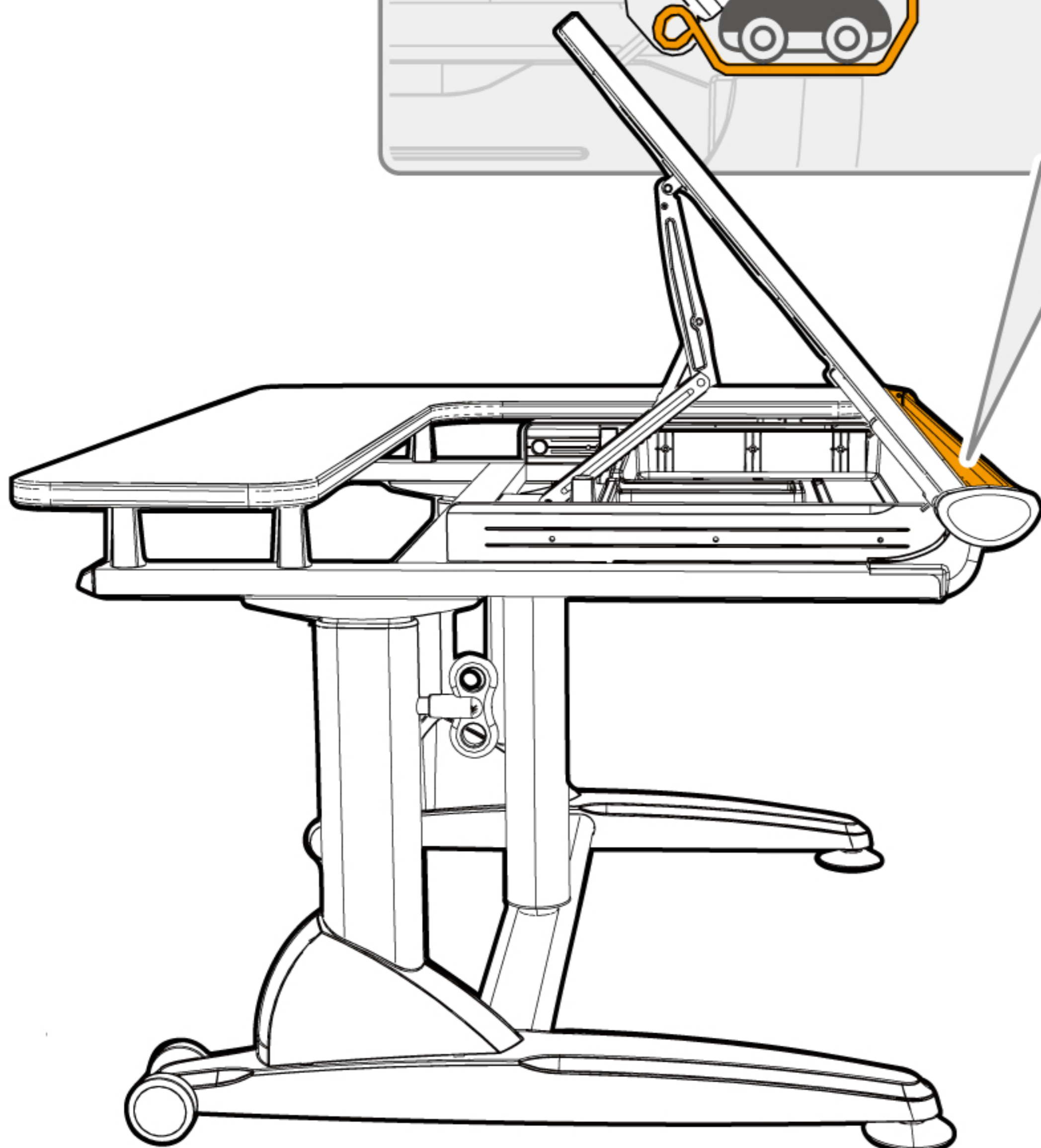
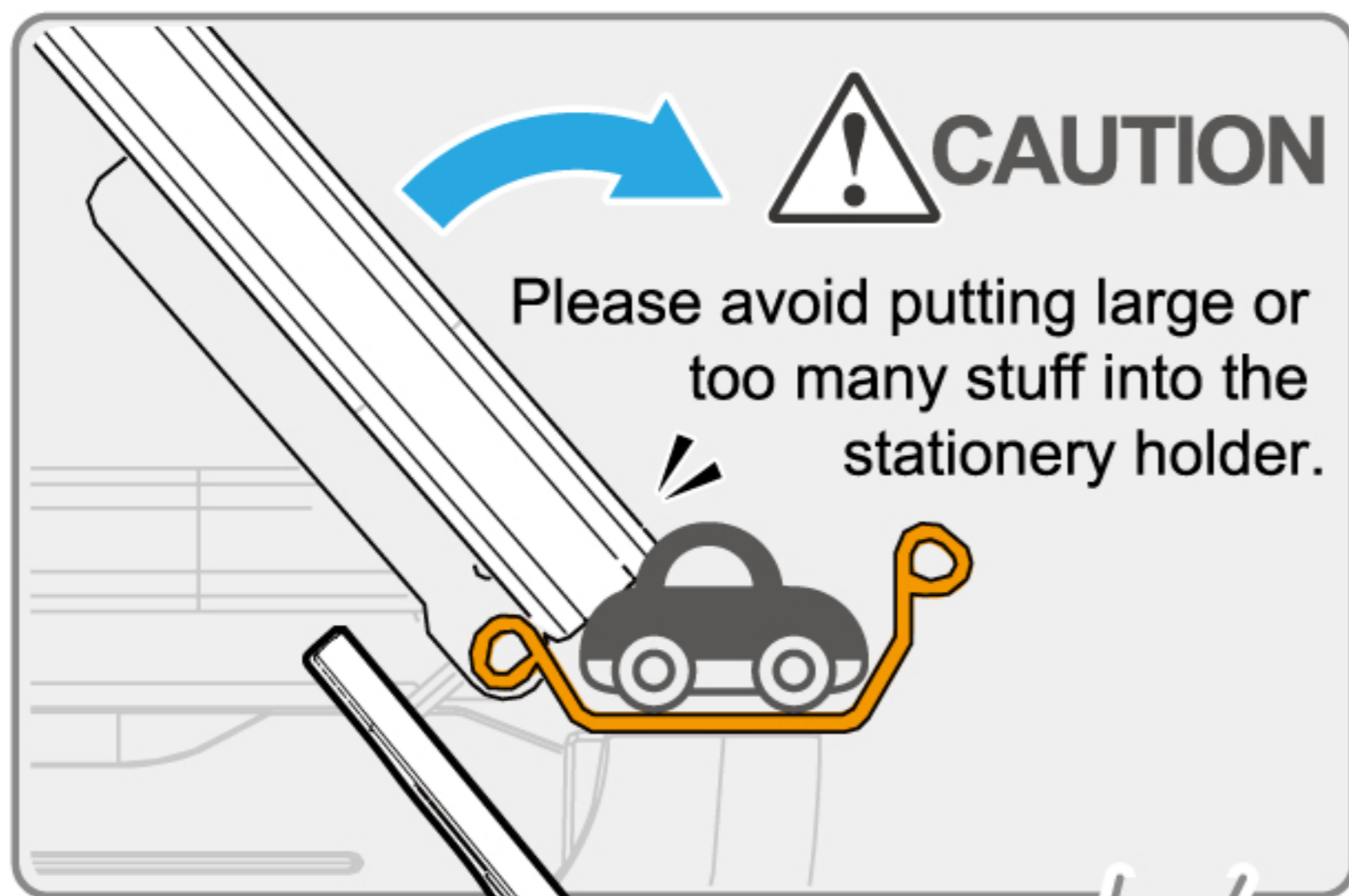

When the tabletop gets stuck, please bend the axle to put down and do not force the tabletop down.

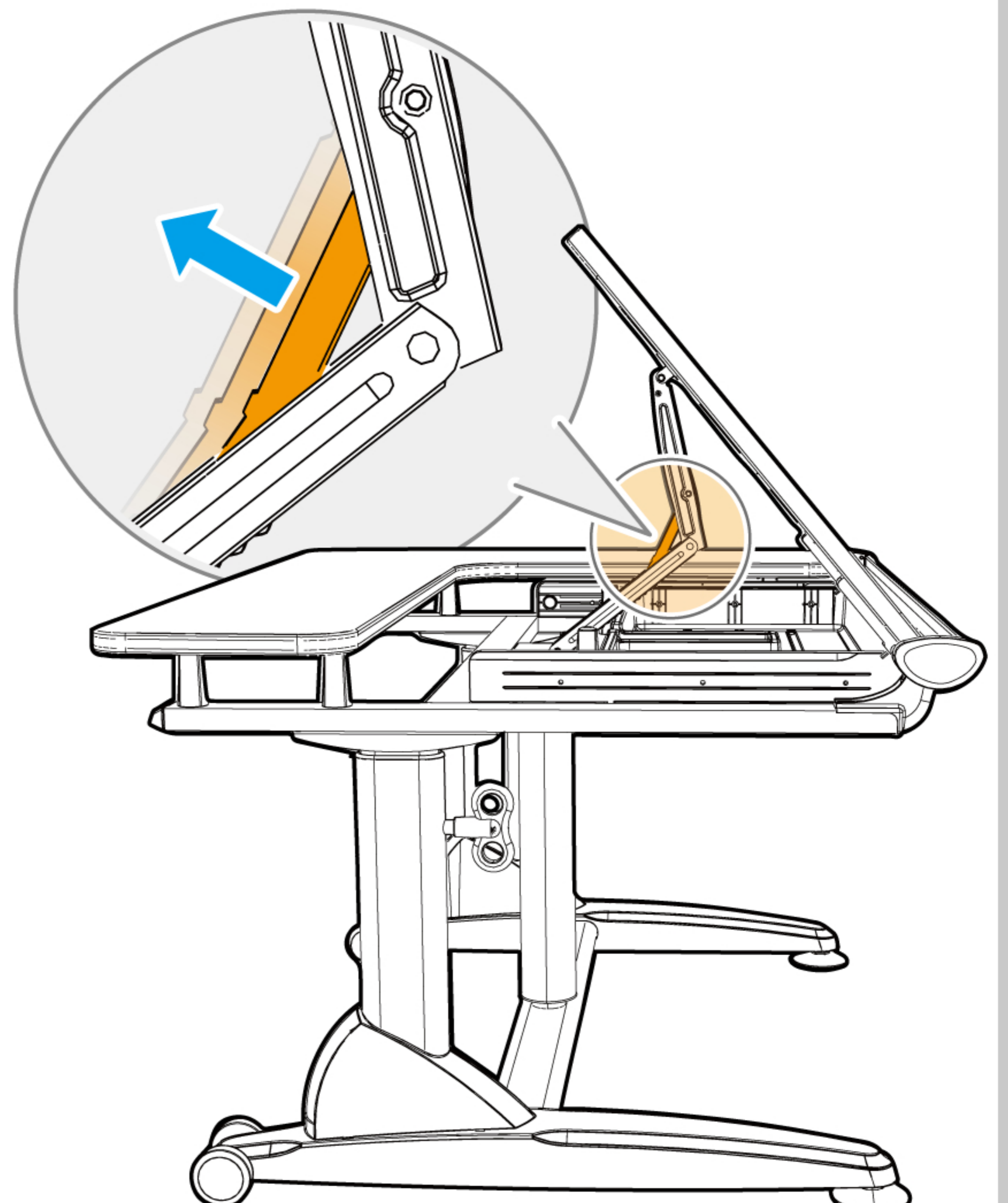

Height adjustment

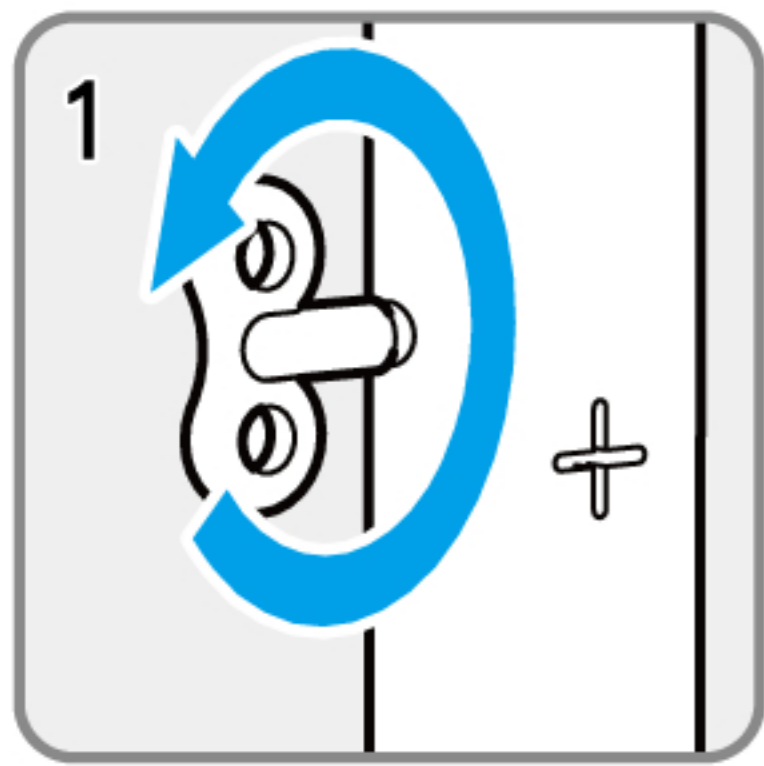

Loosen the leg

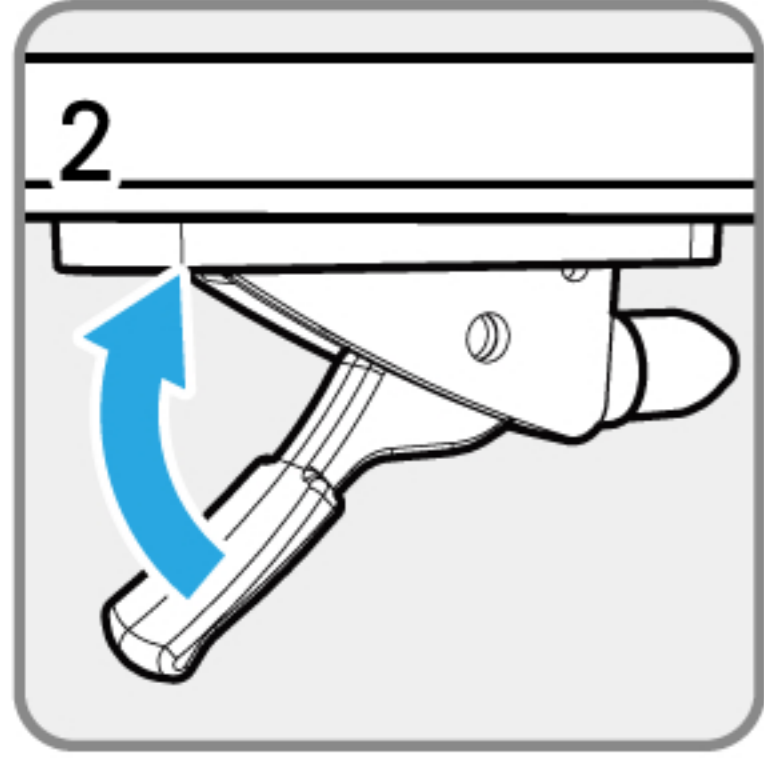

Lift up by lever

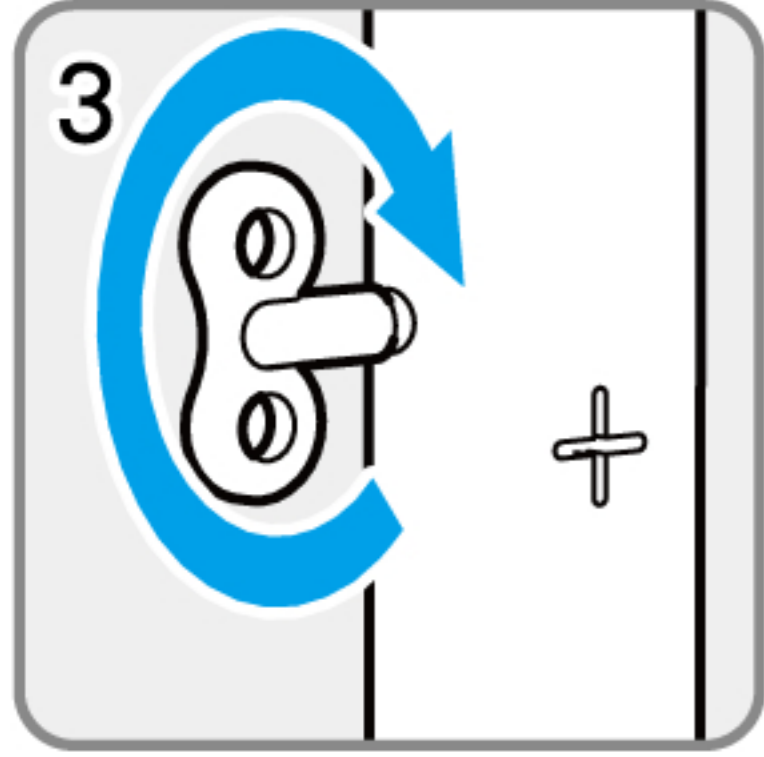

Fix the leg

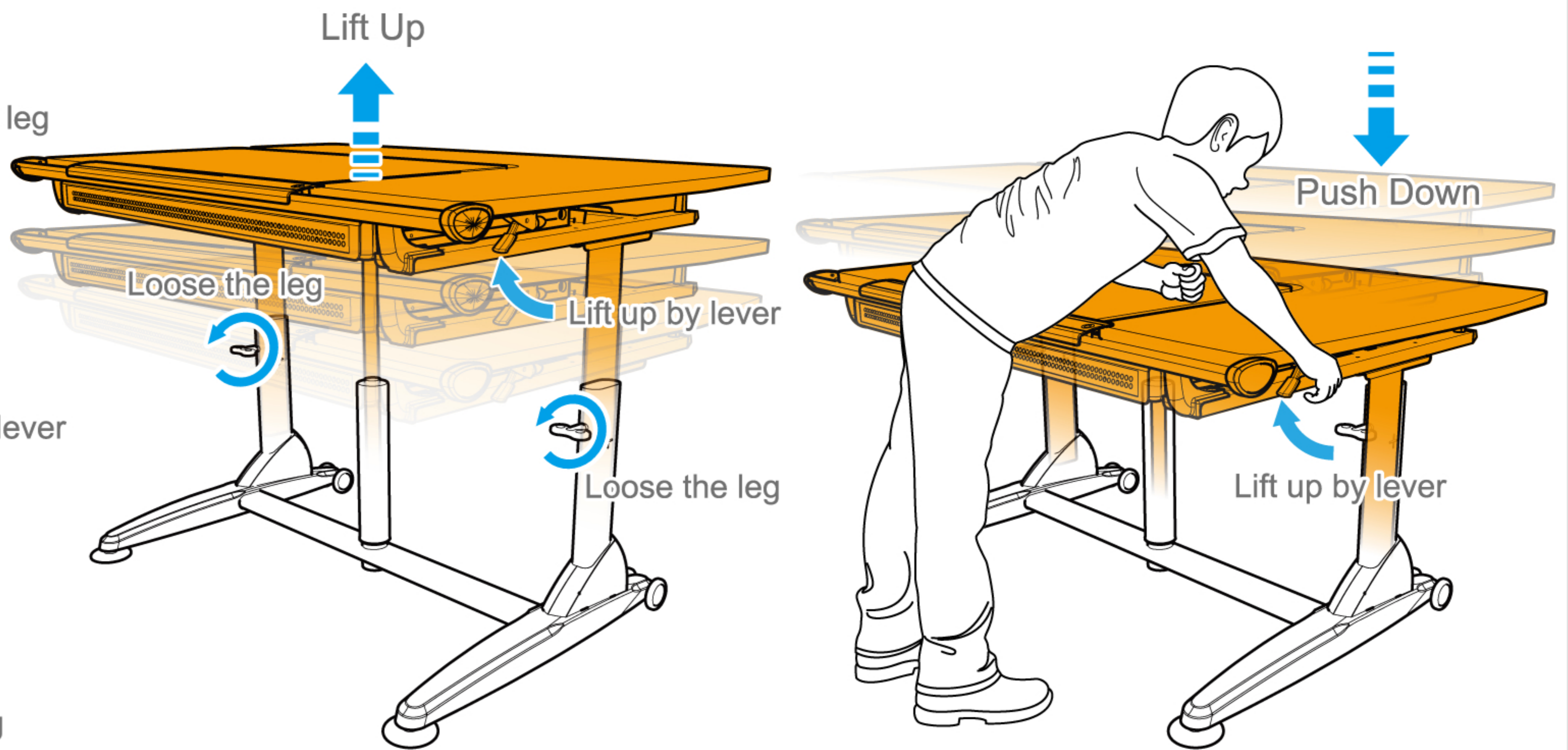

Angle adjustment

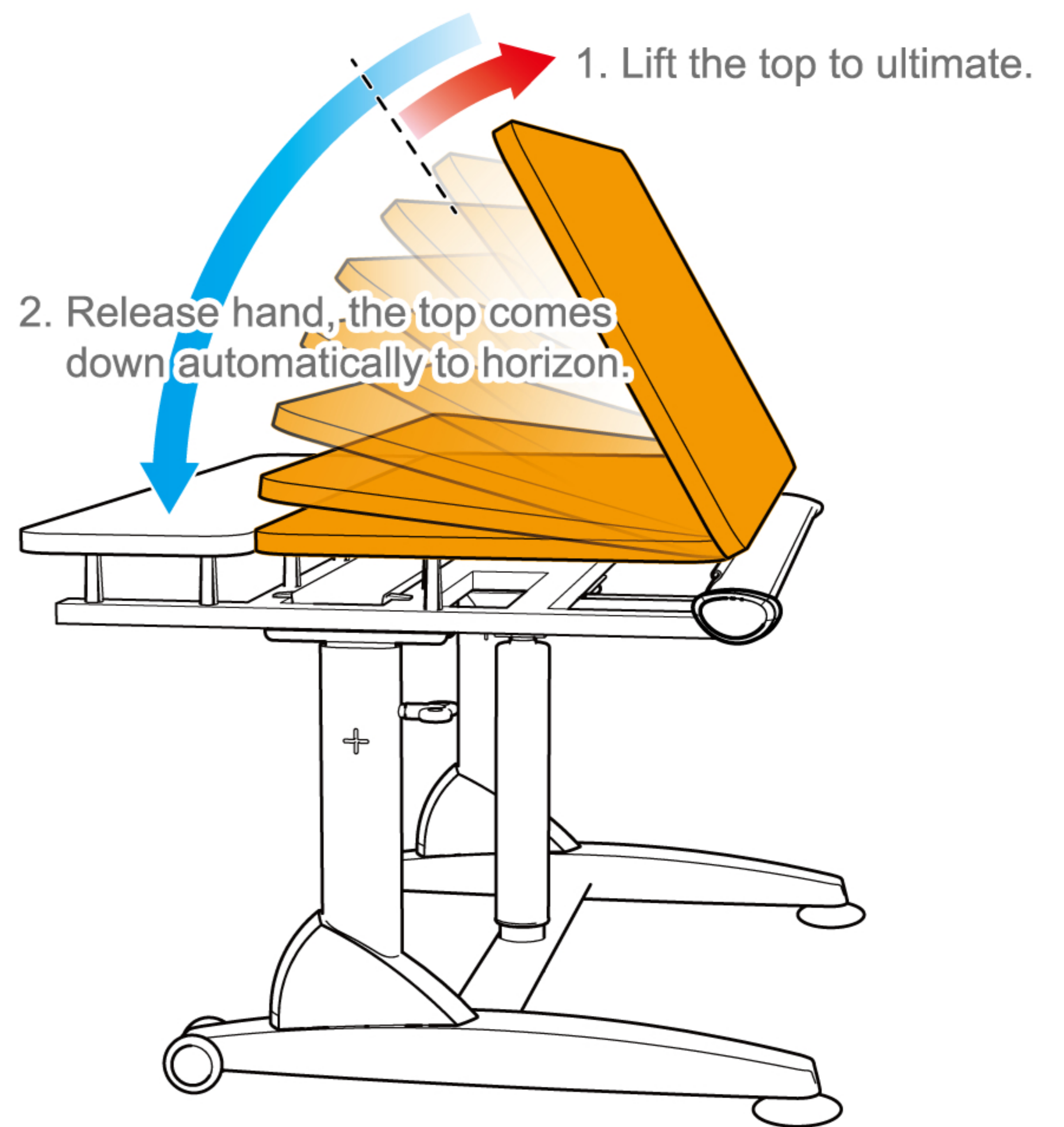
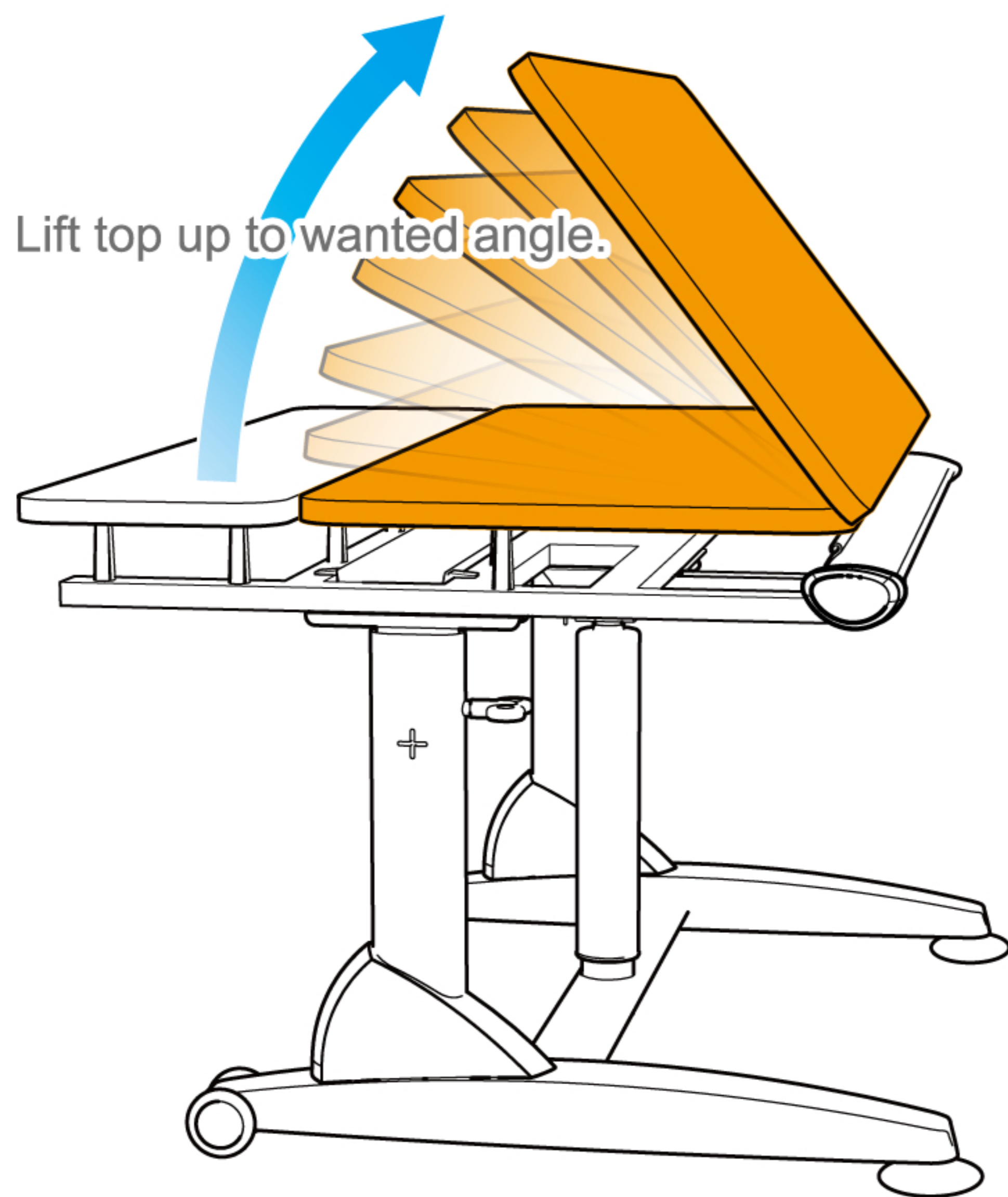

Adults should accompany when operating



A. What's 10+5+1 ?

All Kid2Youth products are tested & international standards certified that we are confident to provide warranties 10 years, 5 years, 1 year for different parts

B. Warranties & services

1. Announcement of the defect to 「Kid2Youth」 & 「TCT Dynamic Workstation」 Origin dealer.
2. Repair or replace same or similar products after defect is verified.
3. No expense , All costs will be bear by 「Kid2Youth」 & 「TCT Dynamic Workstation」 If it is confirmed as defect.
4. Warranty does not apply without Kid2Youth Corporation authorized.
5. Parts replaced by the new, ownership at the same time changed to 「Kid2Youth」 & 「TCT Dynamic Workstation」 .
6. Products shall be adequately replaced if the defected ones are no longer produced.
7. Service works only provided by dealers & distributors authorized by Taiwan 「Kid2Youth」 & 「TCT Dynamic Workstation」 .

C. Assurance Coverage

10-year Warranty: STABILUS Germany made gas lift. (Detail refer to item D)

5-year Warranty: Main, auxiliary structures. (desk top, main body of chair, cabinet, hardware.(Detail refer to item D)

1-year Warranty: All consumables. (PU wheel, adjustable leg. Detail refer to item D)

D. Warranty Exceptions

1. Warranties not cover man-made damages, natural disasters, climate (humid) & improper operation.
2. Warranties not cover damages caused by improper removal, self-repair.
3. Warranties not cover color difference, fading in normal situation.
4. Warranties not cover purchases of samples, exhibits and cross-out.
5. Warranties not cover used products buyers.
6. Warranties not cover products without warranty policy issued by dealers & distributor or agents of 「Kid2Youth」 & 「TCT Dynamic Workstation」 .
7. Amendment right is reserved by 「Kid2Youth」 & 「TCT Dynamic Workstation」 at any time.

E. Maintenance Guide

1. Careful study assembling instruction & operational manual is needed.
2. Randomly disassembling is forbidden. It will be operated by trained workers if unavoidable.
3. Regularly check and lubricate are strongly recommended.
4. Regularly adjust heights to smooth the gas lift system.
5. Regularly check screws, make sure all tightened.
6. Erosive cleaning agents & rough fabric are forbidden. Keeps products dry at all time.

Troubleshooting

Having trouble up and down the desktop?

- Check if any weight inclined to the side that makes the top not in good balance.
- Make sure if the desk is horizontal placed on the ground.
- Above mentioned not found, problem remained. Suggest to have all screws half-loosen.

Tight them up one by one diagonally.

Problem remained after tried all. Contact dealer or distributor for better solution.

Angle adjuster not in functioning?

- Pliers to clip where the top stuck
- Oil lubricating to rule out the noise if any.

Having trouble up & down the desktop? after period of time.

- Check if any weight inclined to the side that makes the top not in good balance. Remove or place it on the center!
- Remove stuff from the desk. Hand pulling simultaneously, pull the wire control to lift up the desktop. Repeat it couple tims.





G2C+/G6+/G6C+ 조립 설명서



주의사항

- 4살 이상 사용
- 성인에 의해 조립
- 아이가 사용시에 어른이 함께 하십시오.
- 3세 미만의 어린이는 사용할 수 없음. 작은 부품을 포함하고 있음.



1 상판 G2C+ | XXS XS

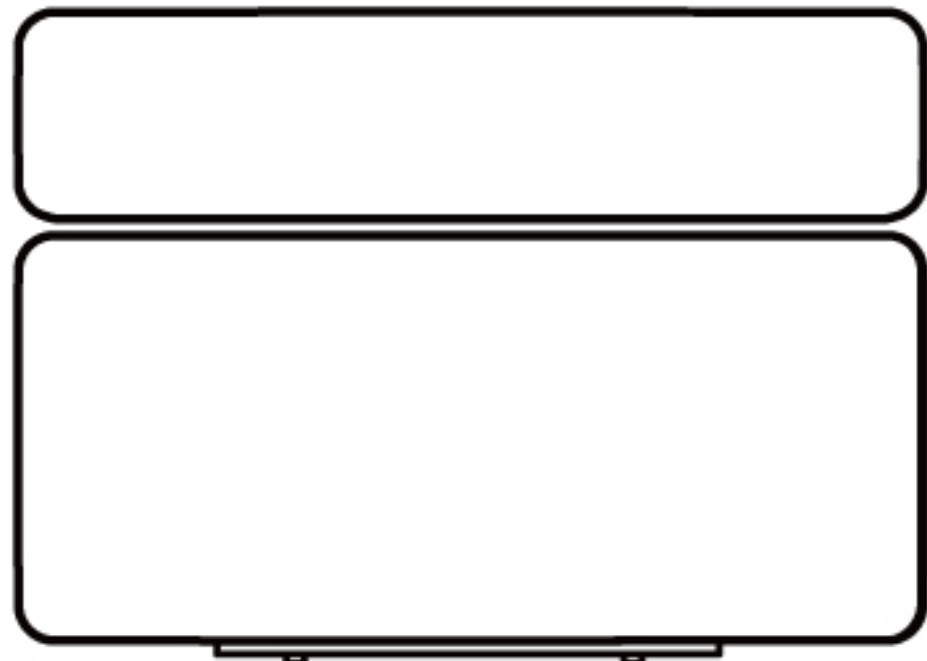

G6+ | XS S

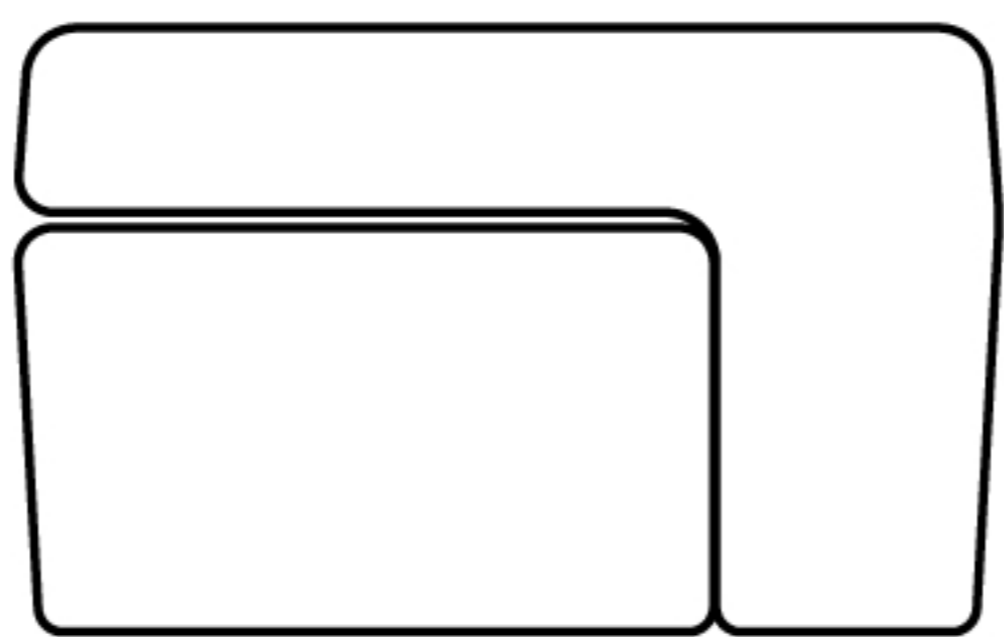

G6C+ | XS S

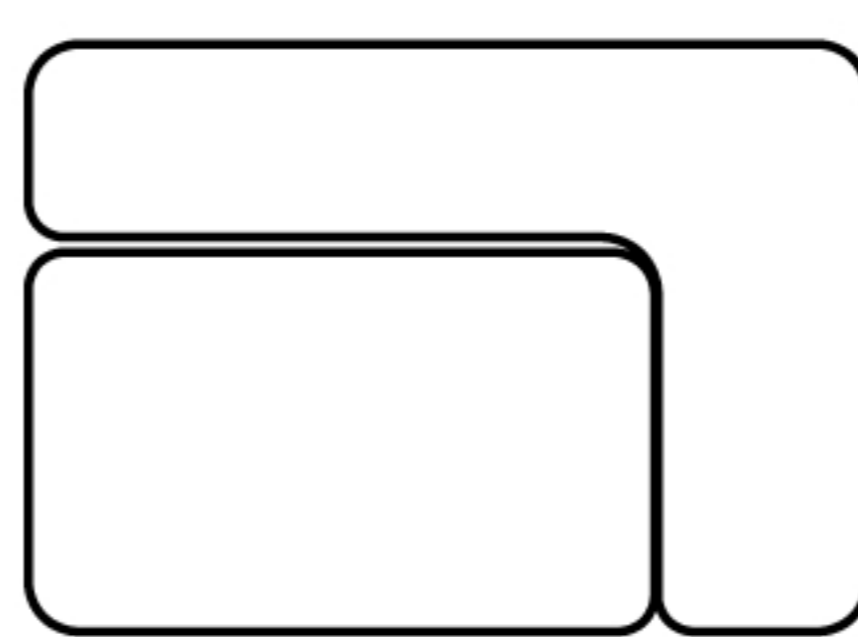

2 오일 버퍼



H 나사
4.8*14mm

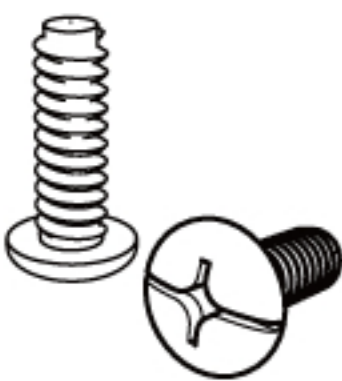

E 나사
M4*12mm



3 다리

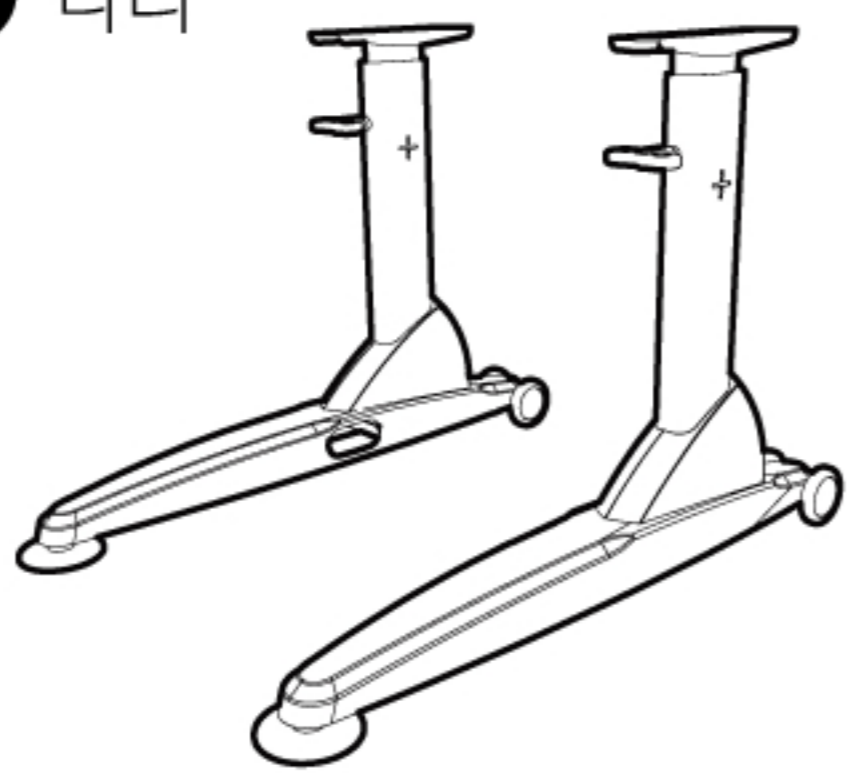

4 수평사프트

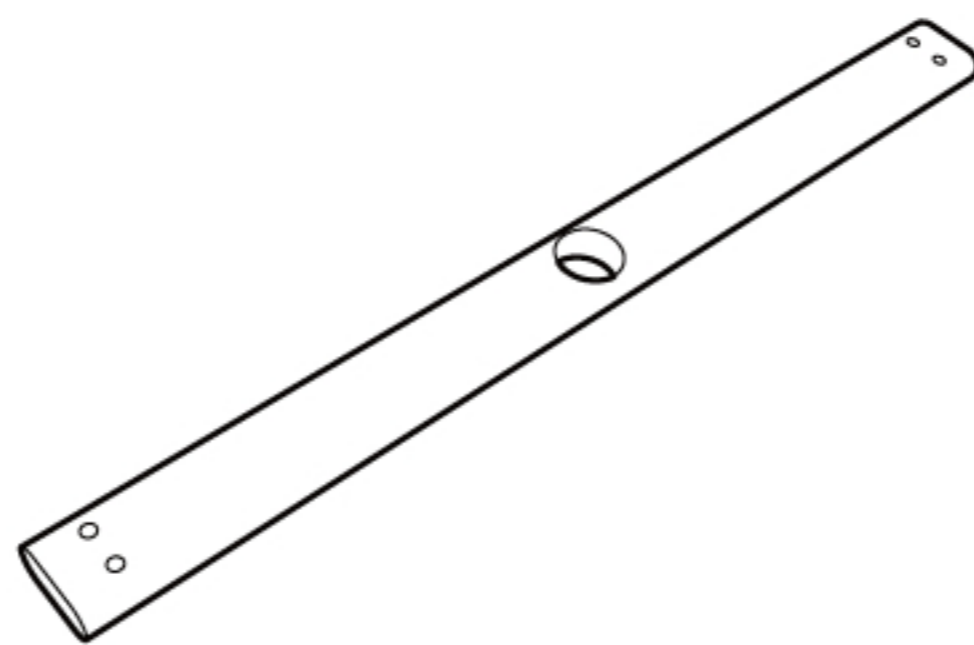

5 장착 판

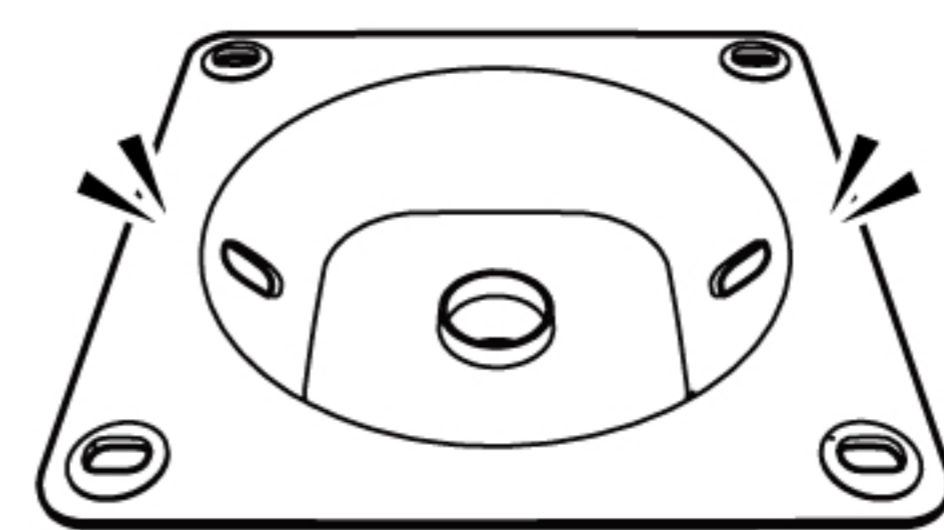

6 가스리프트

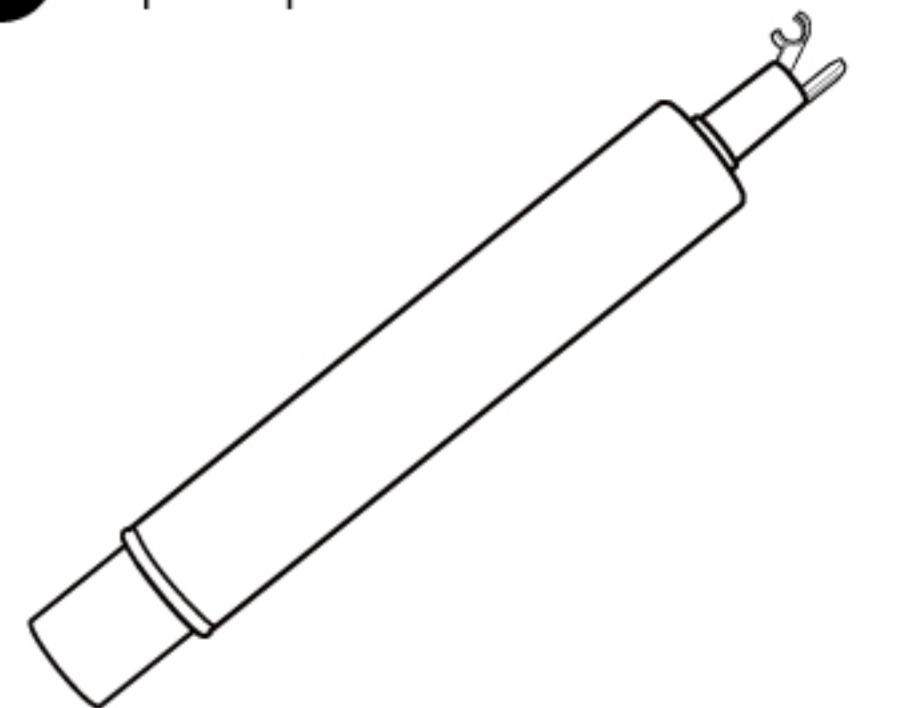

7 와이어 컨트롤러

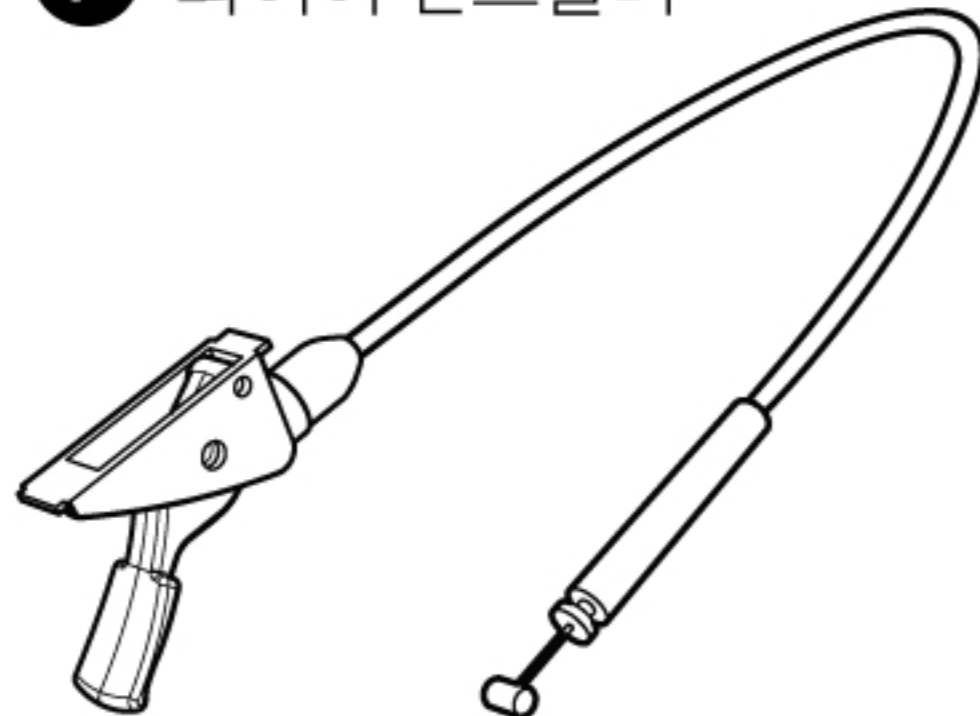

8 S 케이블 정리대

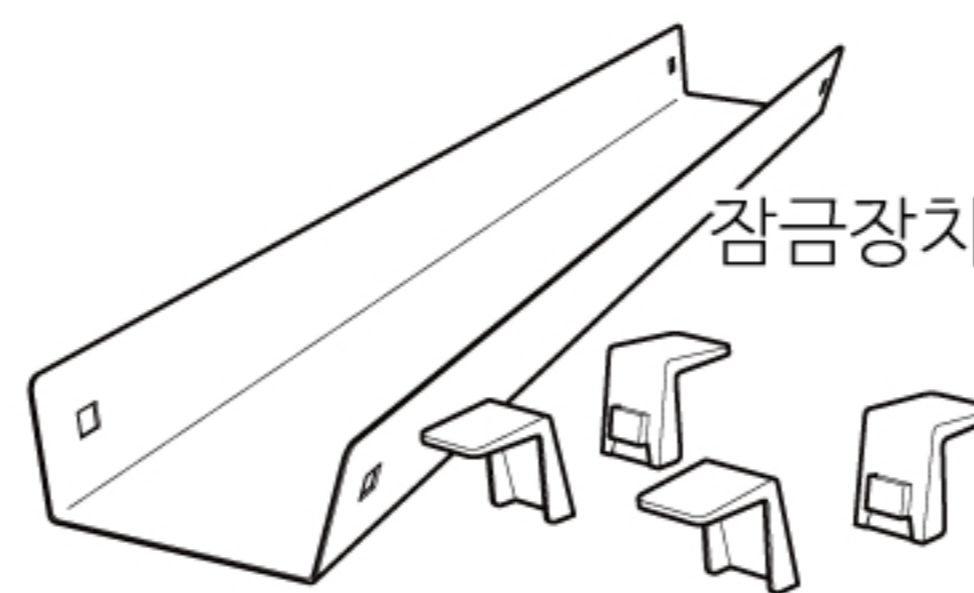

9 손목 받침 자

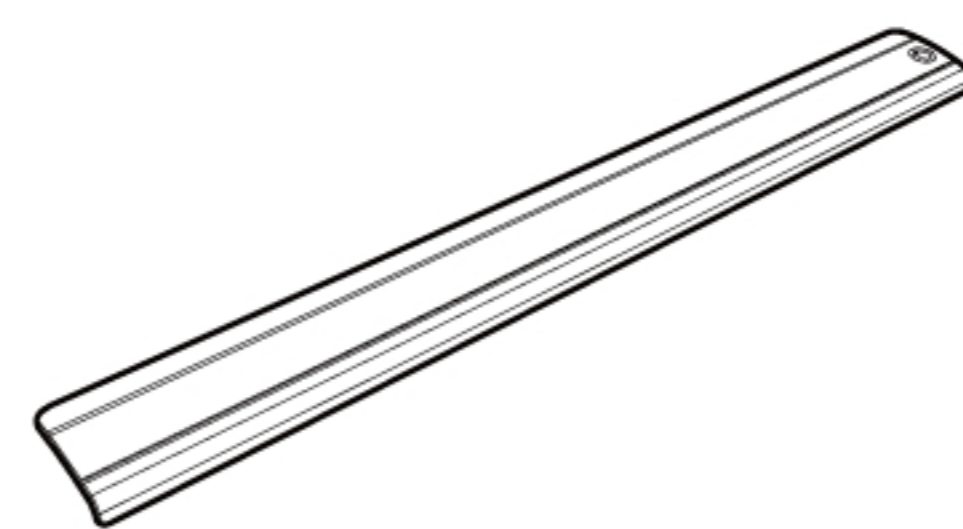

Parts Kit

A 육각나사 X 4

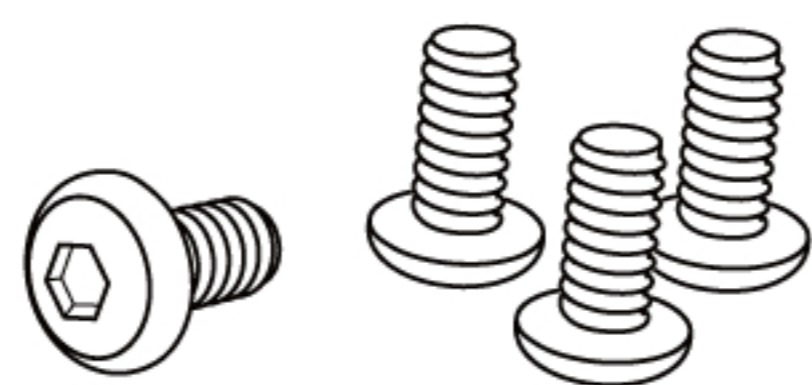

1/4*15mm

A 육각나사 X 4

B 와셔 X 4



1/4*15mm

C 육각나사 X 4

D 와셔 X 4

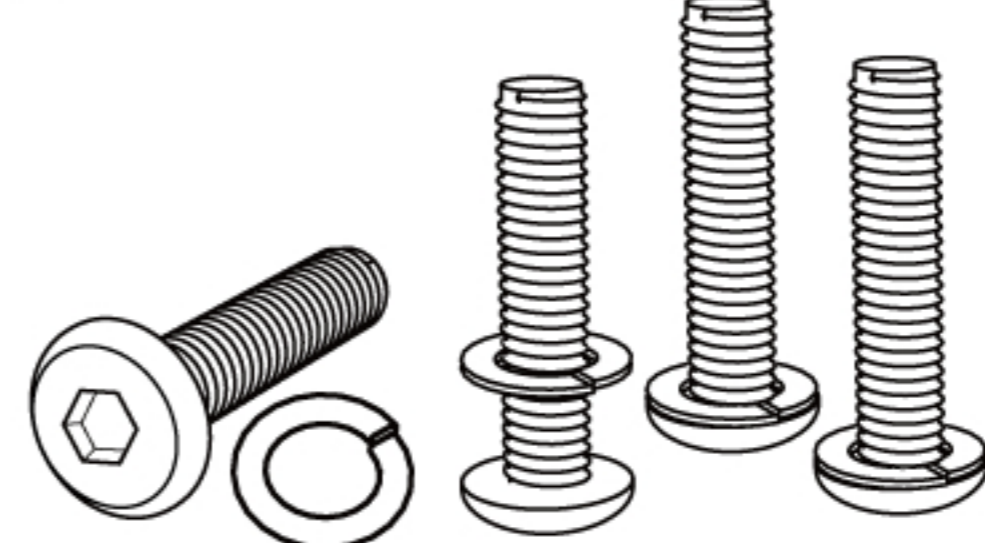

M8*38mm



육각 키 렌치 NO.4

1 소품 트레이를 먼저 빼냅니다.
오일 버퍼 2를 나사 구멍에 맞춘 다음 나사 H & E를 단단히 조입니다.

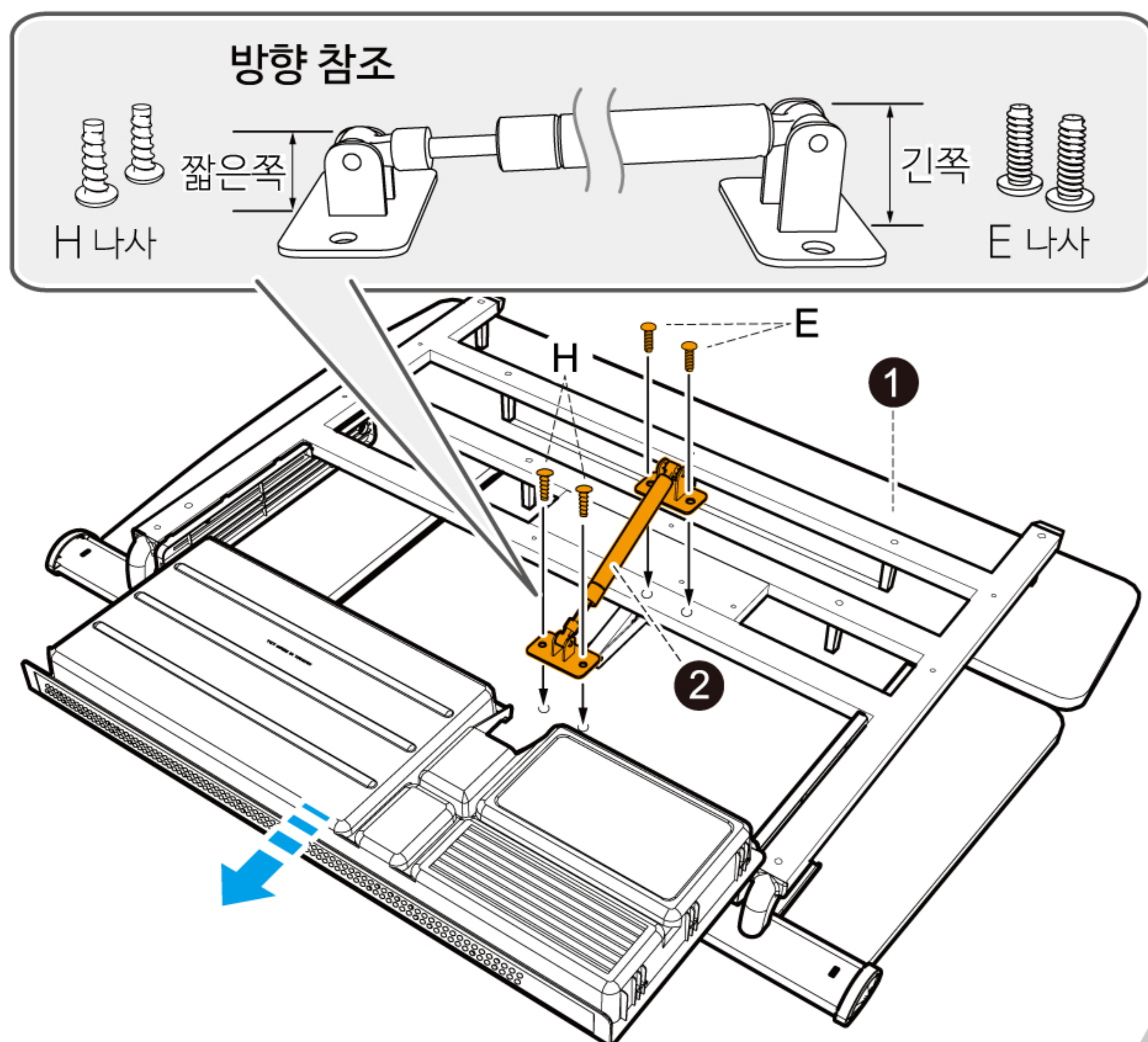

2 가스 리프트 6에 장착 플레이트 5를 삽입하십시오.
장착판 5에 와이어 컨트롤러 7을 설치하십시오.

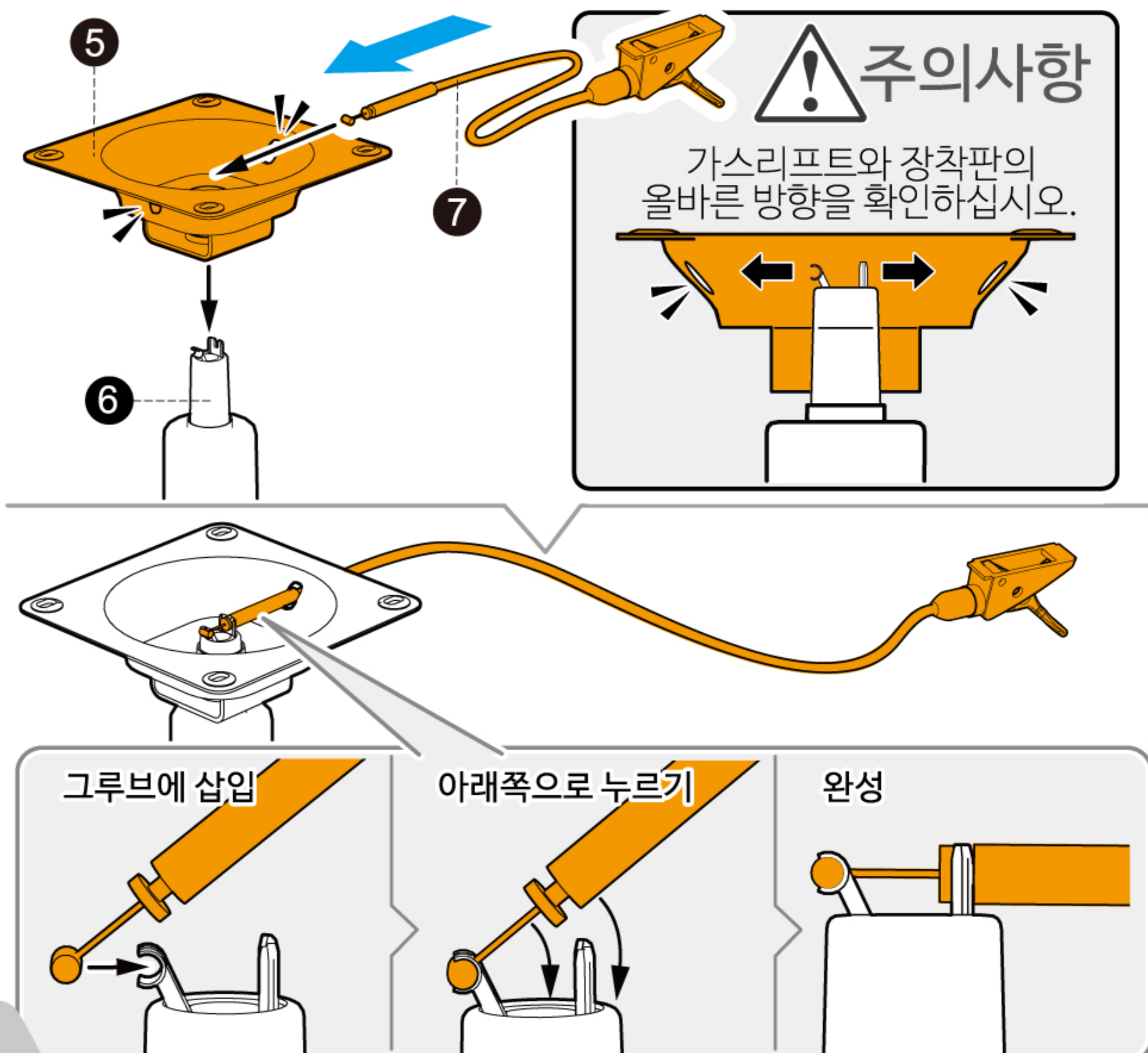

3 나사 A / B를 순서대로 조입니다.

3mm남겨 조이기

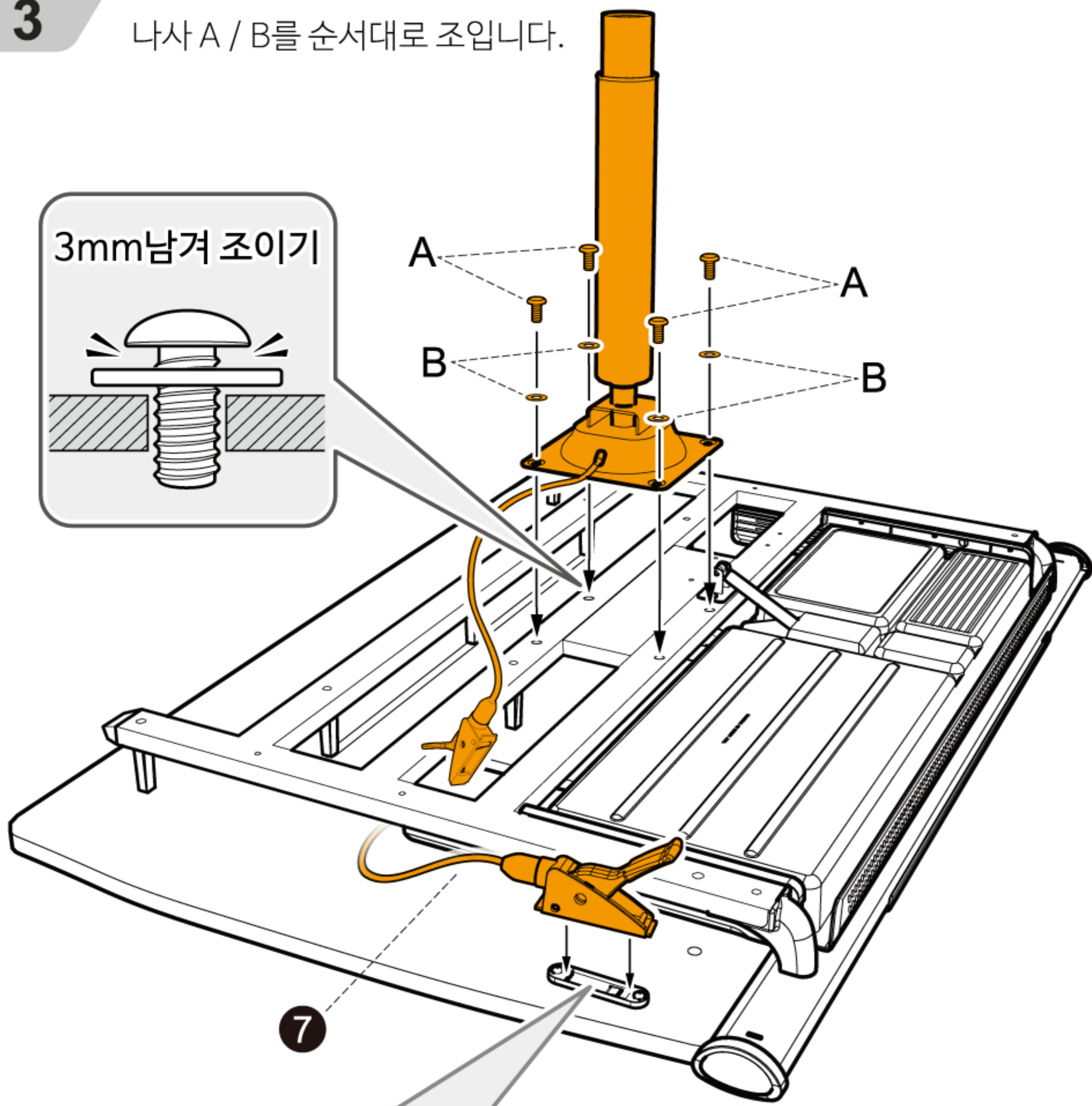

그루브에 삽입

아래쪽으로 누르기

뒤로 당겨
단단히 고정



4

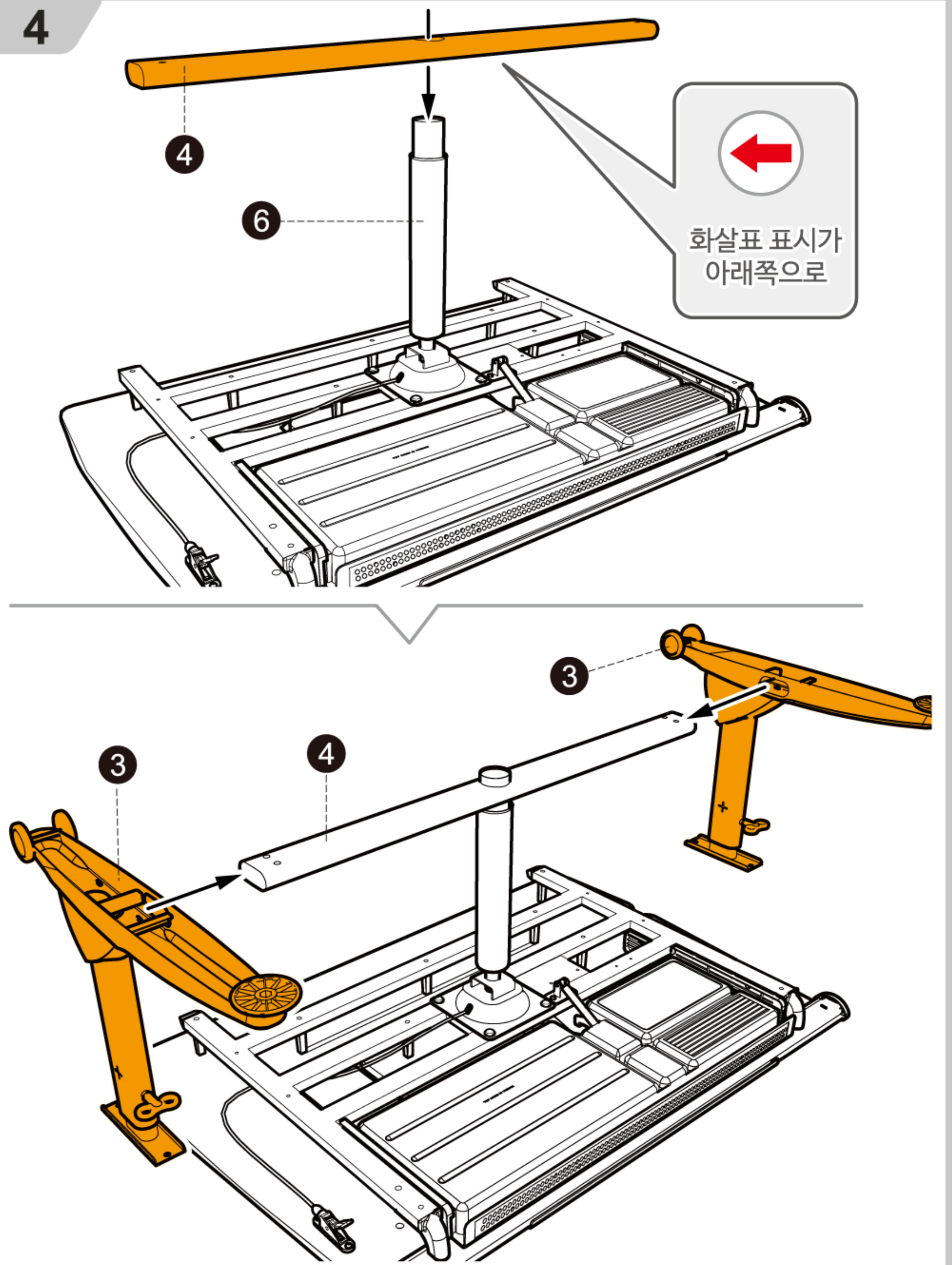

화살표 표시가
아래쪽으로

5

조임 상태를 점검하세요



주의사항

양쪽 다리의 수평 여부를 확인합니다.

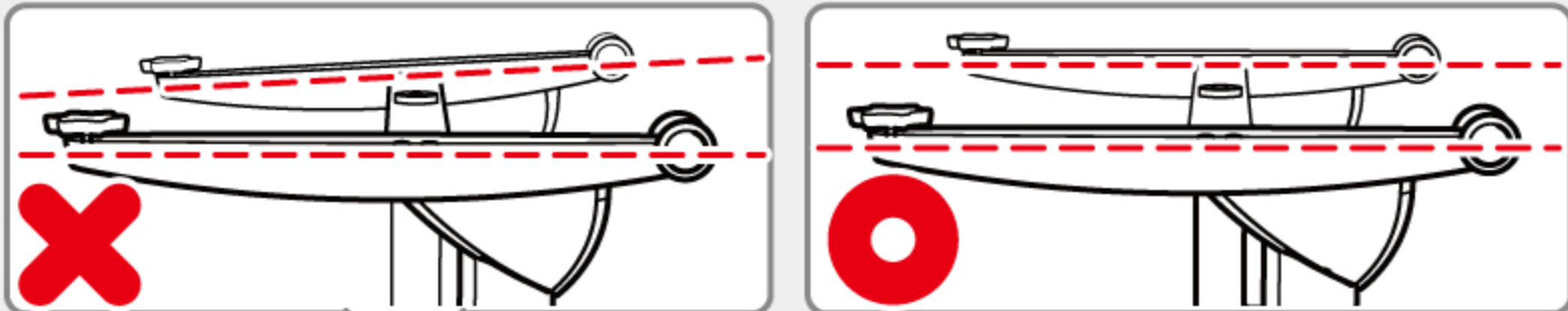

책상 다리가 수평이 아닐 경우

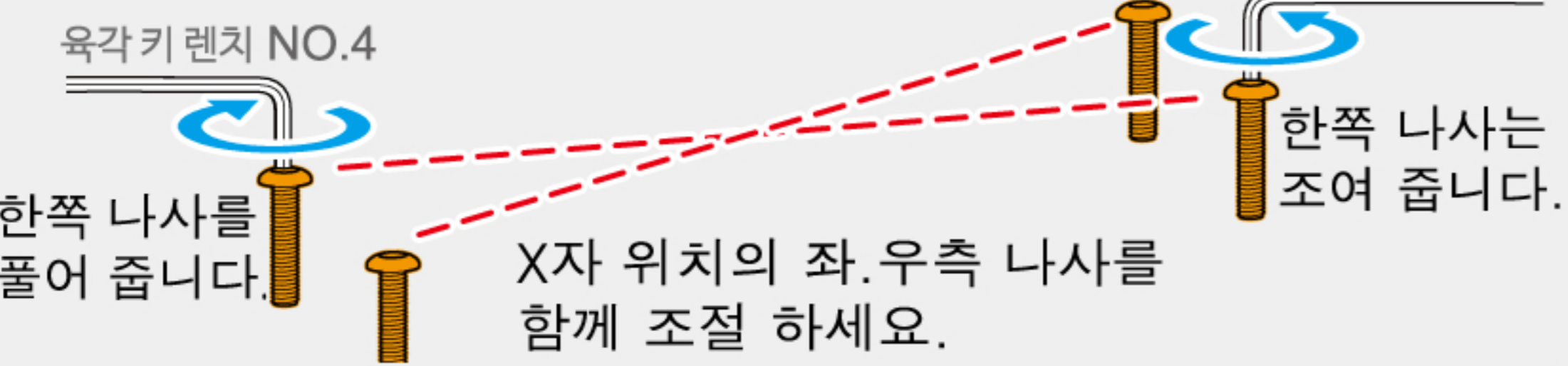

나사 C / D를 순서대로 조입니다.

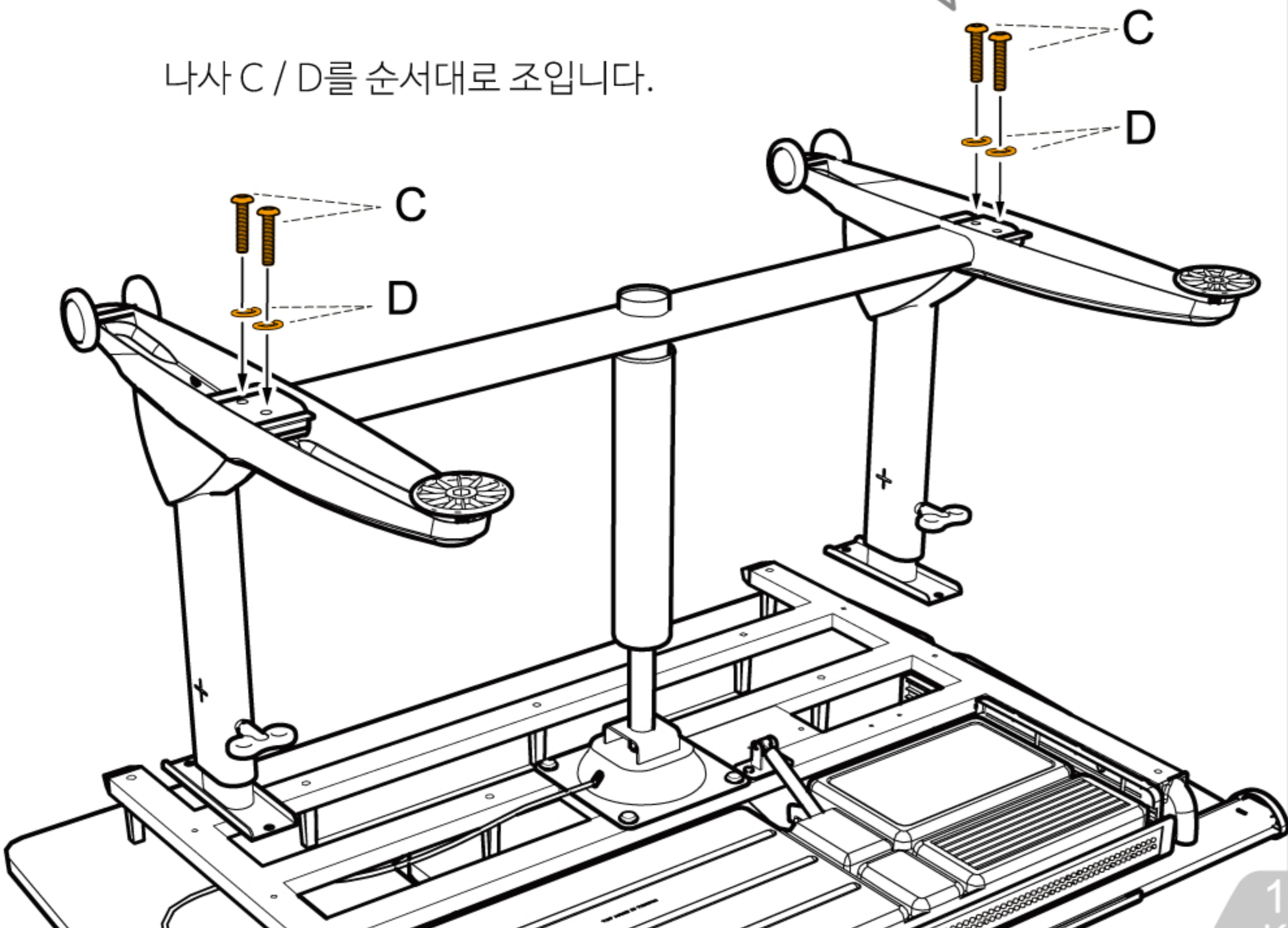

6

Step1. 손잡이를 폼니다.

Step2. 이너튜브가 미끄러져 충돌할수 있으니 유의하세요.

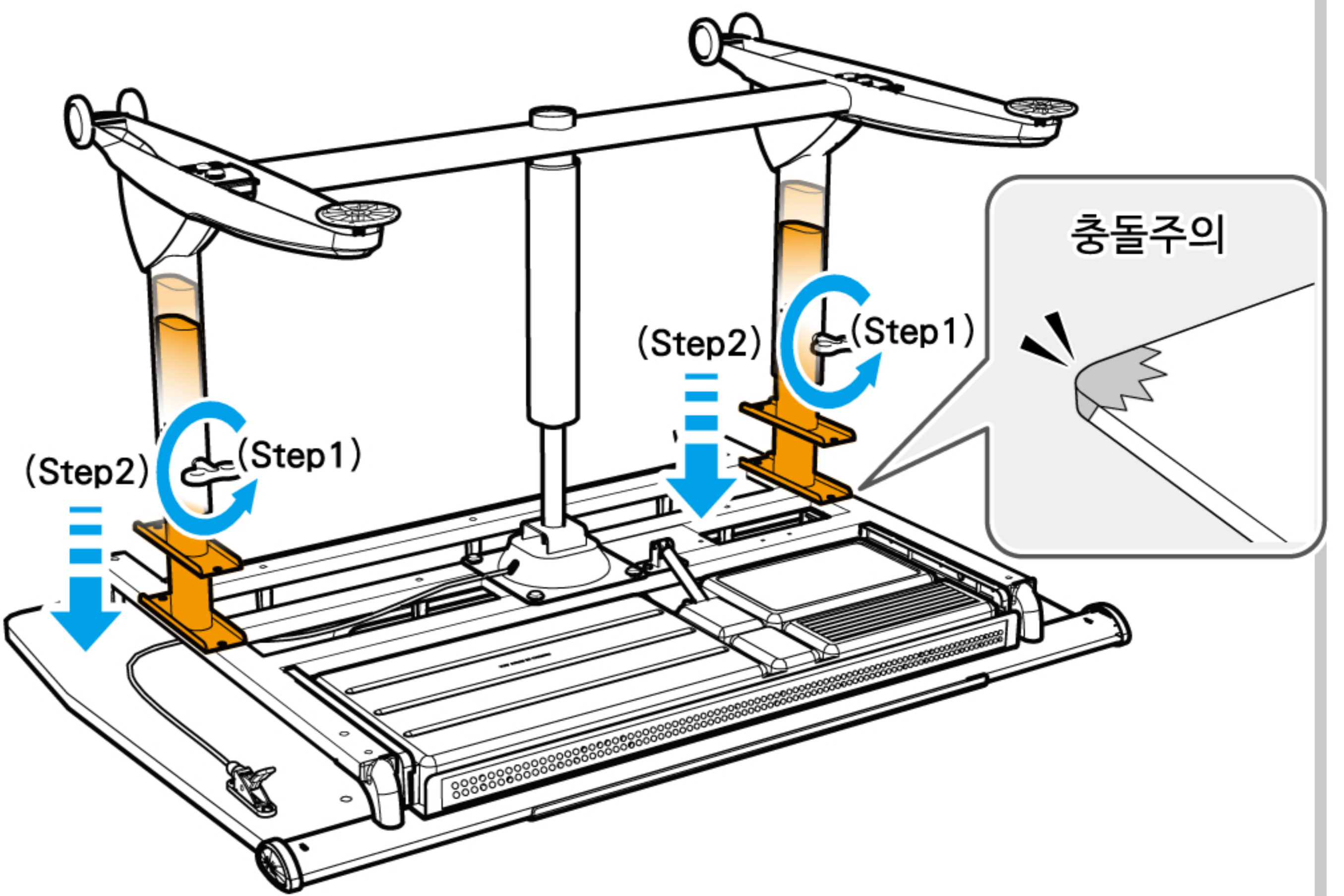

충돌주의

나사 A를 설치하되 조이지 마세요.

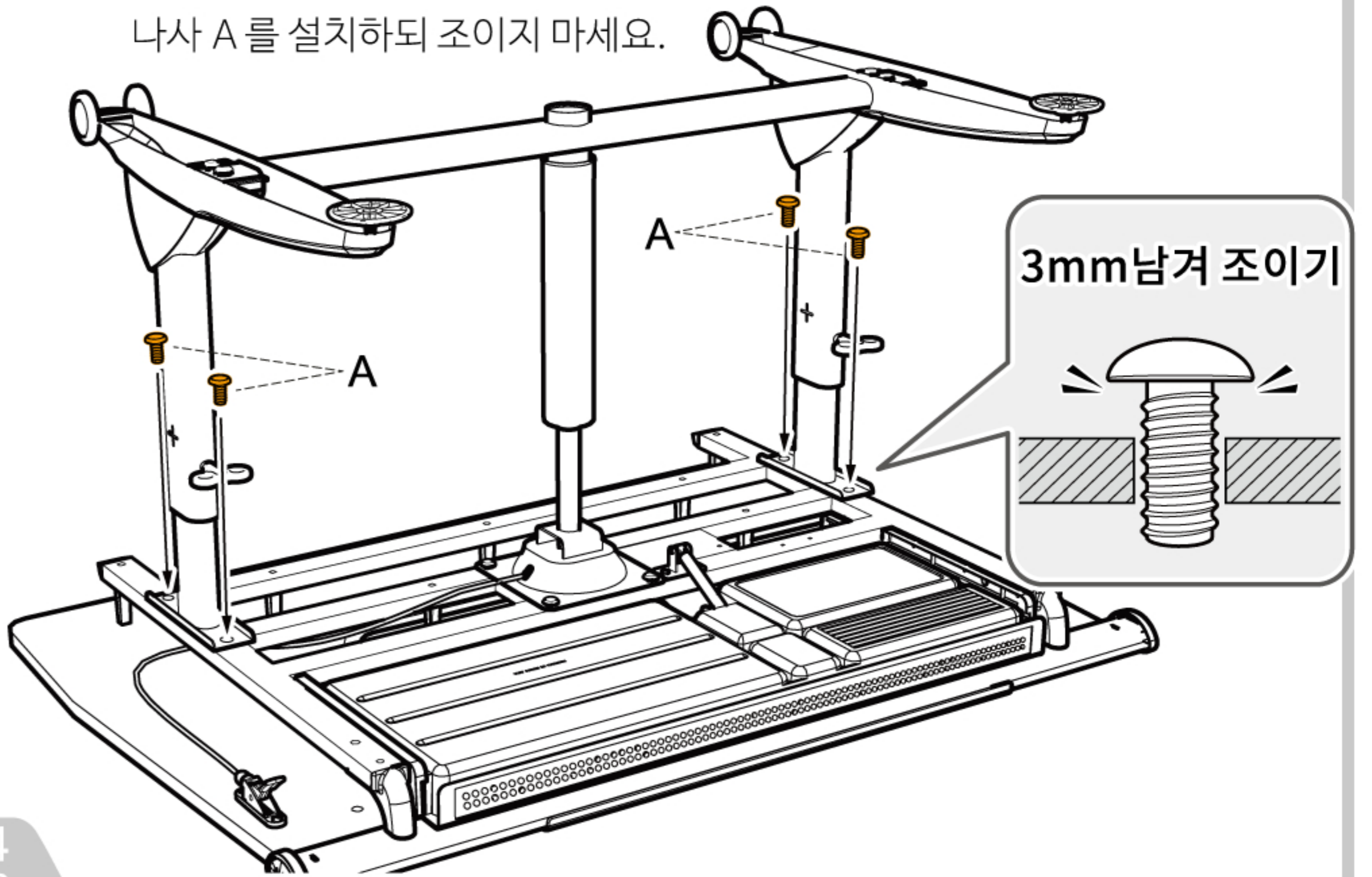

3mm남겨 조이기

7 Step1. 와이어 컨트롤을 당기고 데스크가 부드럽게 작동할 때까지 위 아래로 반복하십시오.

Step2. 여분을 둔 나사를 모두 조입니다.

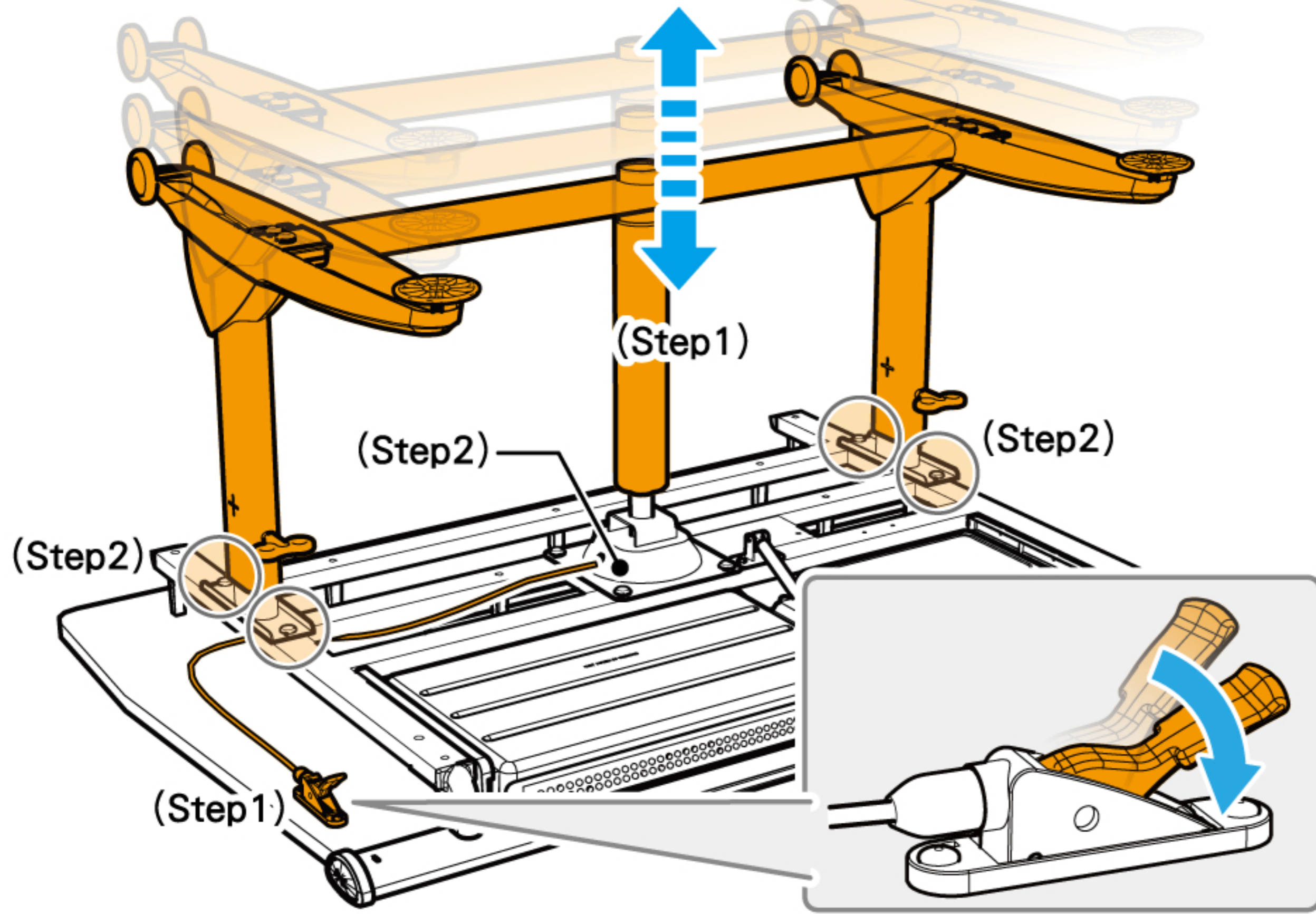

8

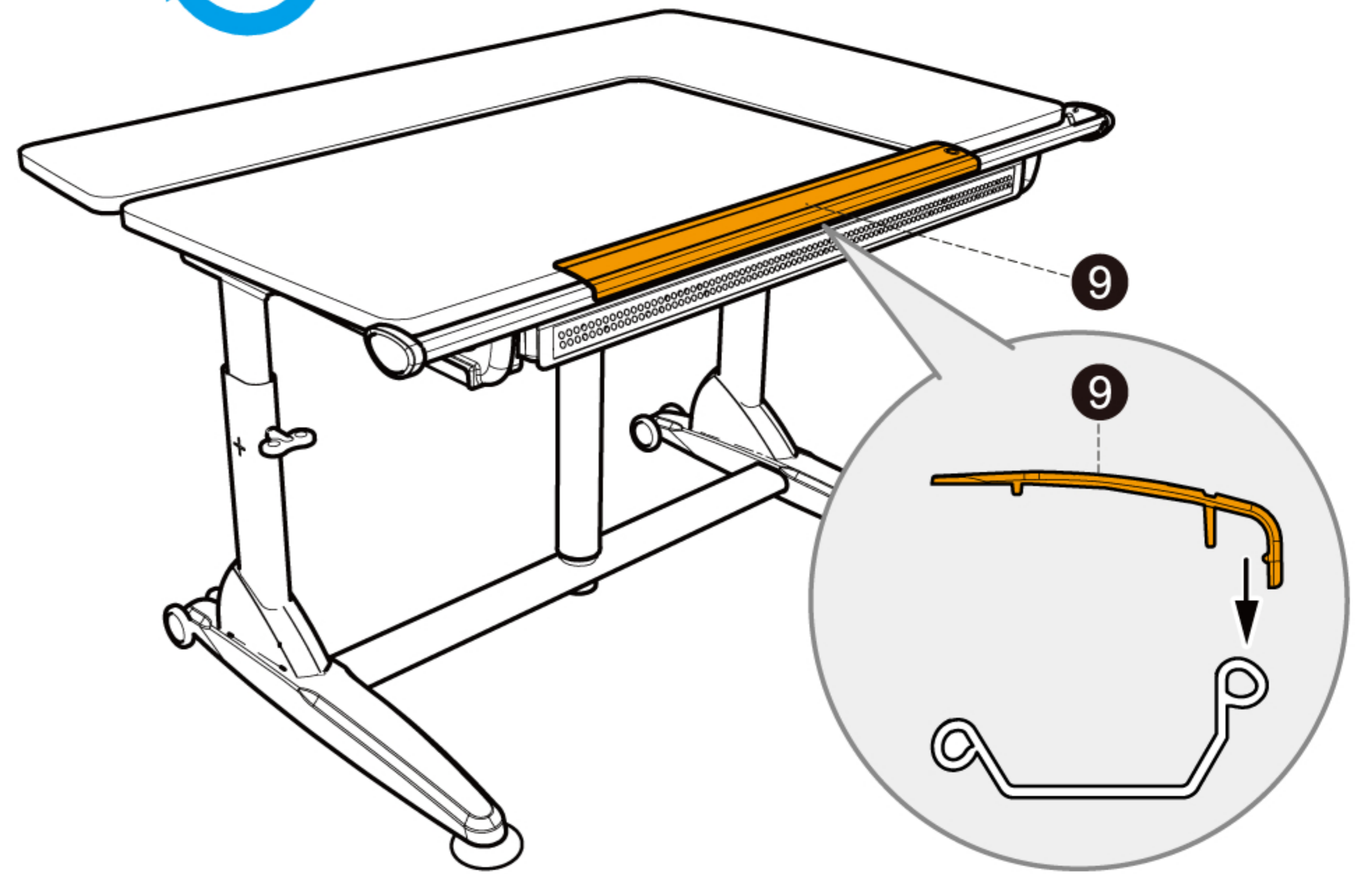

주의

책상의 균형이 잡히지 않은 상태에서는 물건을 올려 놓지 마십시오.



책상 무게가 과부하되면 손으로 높이를 조정하십시오.



설명



주의사항

연필 트레이에 큰 물건이나 너무 많은 물건을 넣지 마십시오.

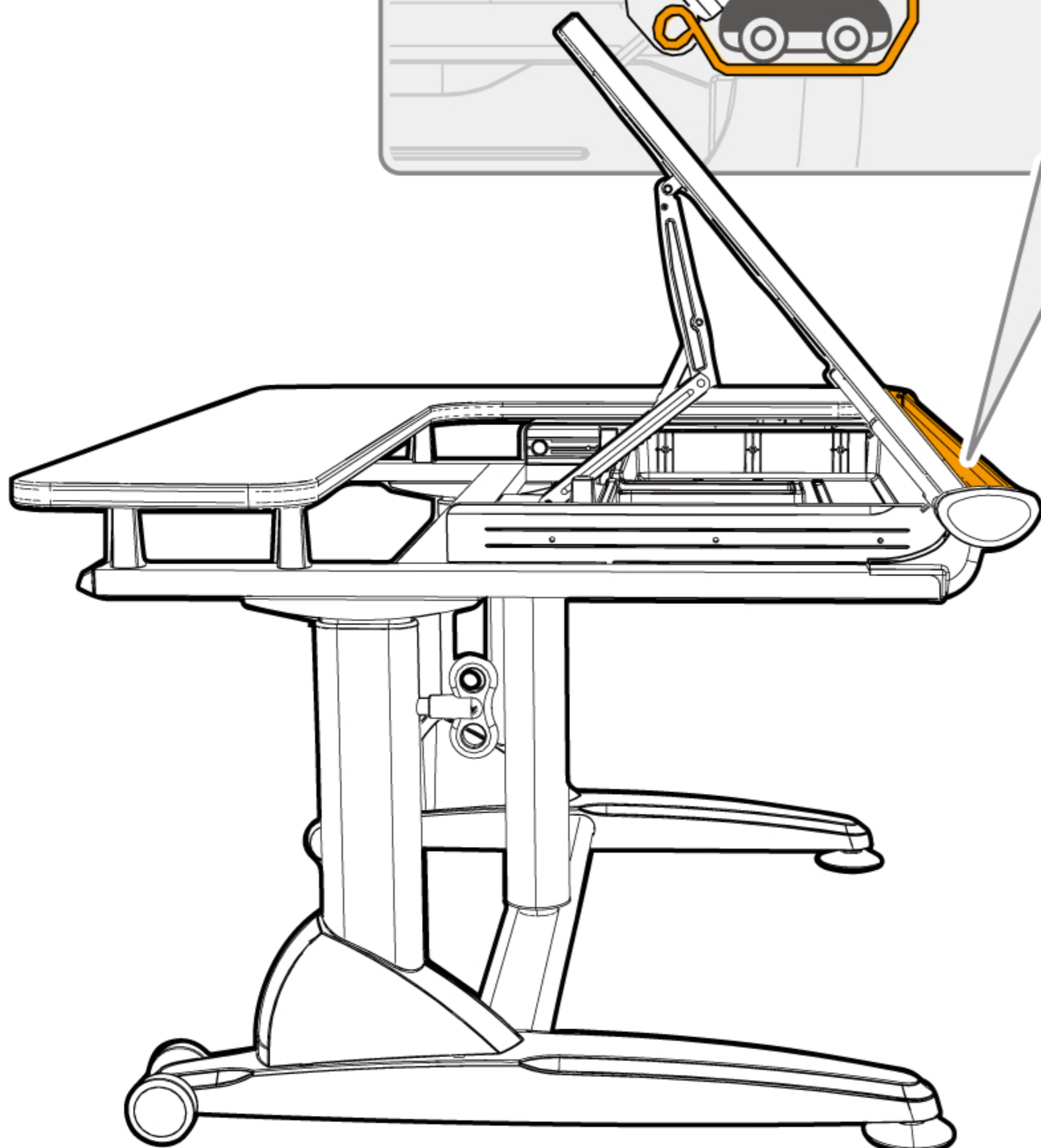

테이블 상판이 움직이지 않을 경우 화살표 부분을 빼내십시오. 테이블 상판을 강제로 내리지 마십시오.

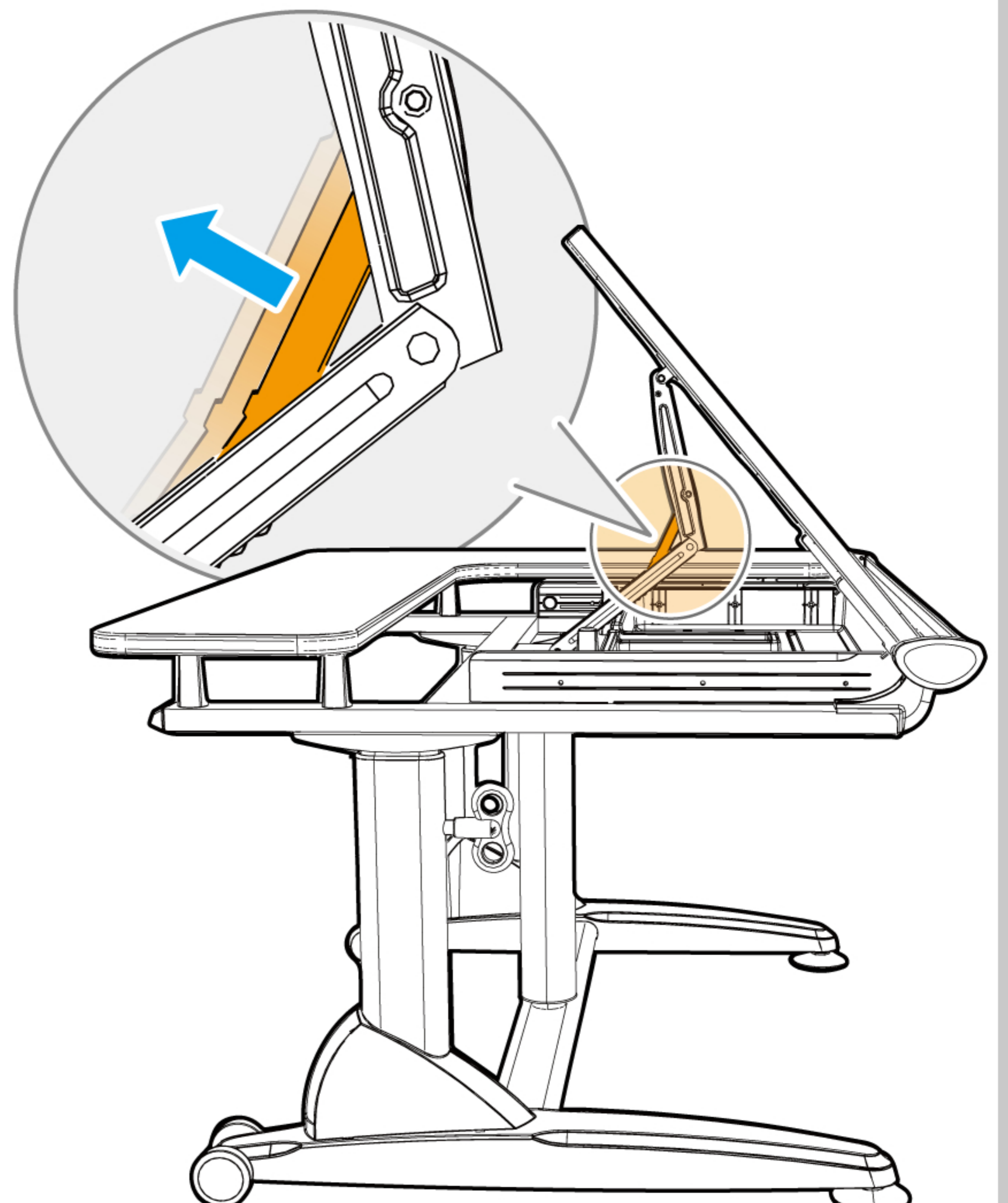

높낮이 조절

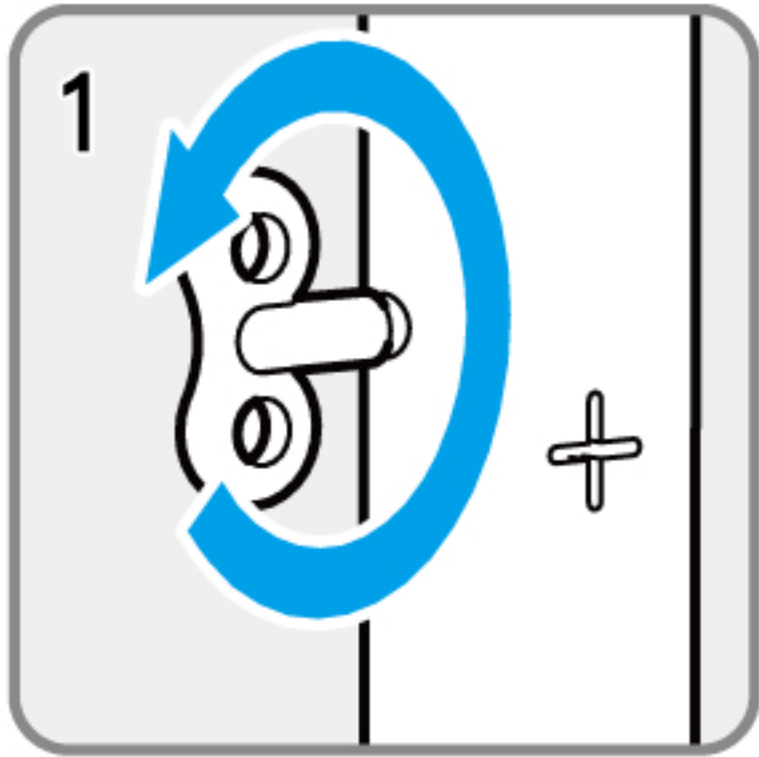

다리높이 고정 나사를 풀어주세요.
시계반대방향

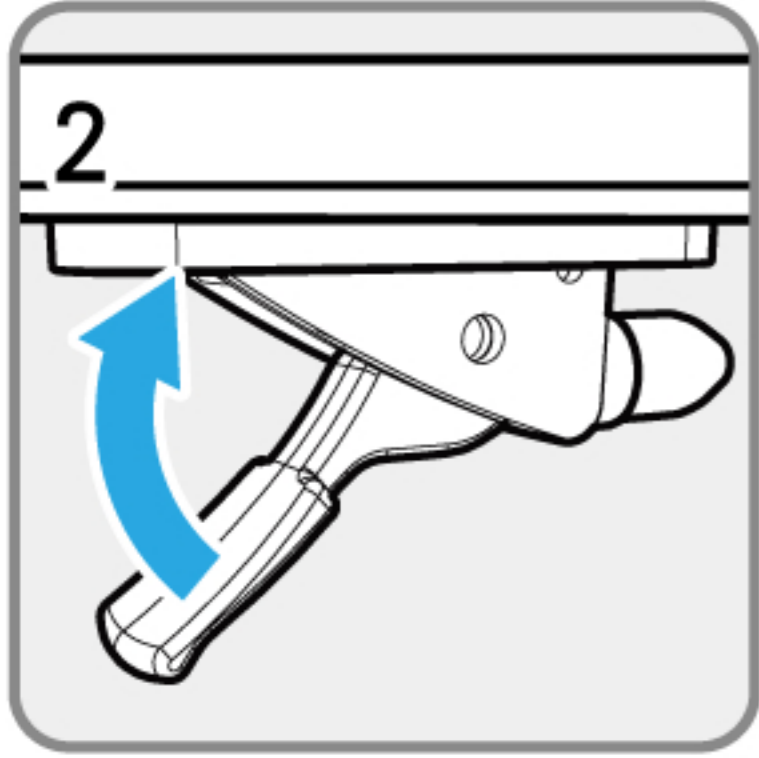

레버를 당겨 올려주세요.

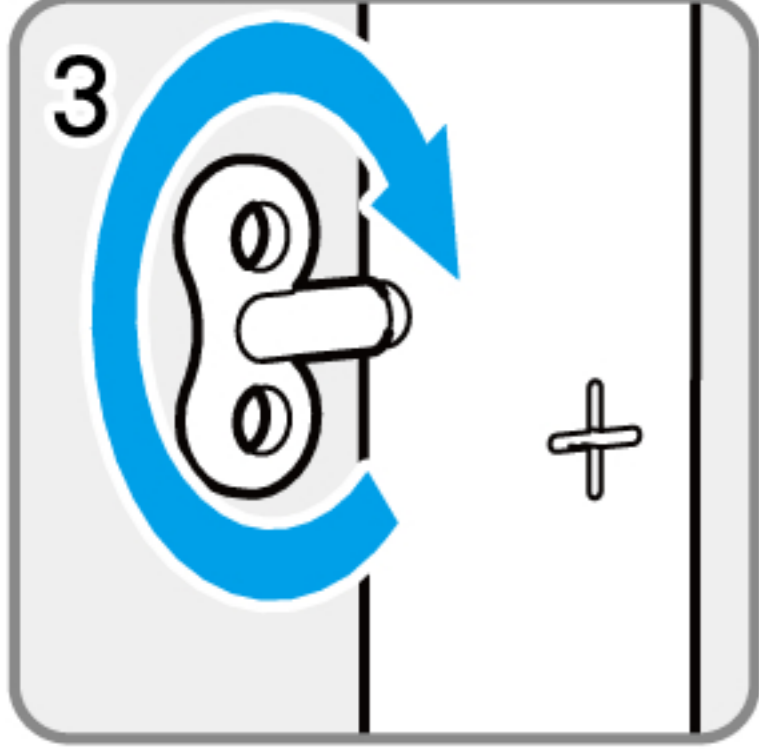

고정나사를 조여 고정합니다.
시계방향

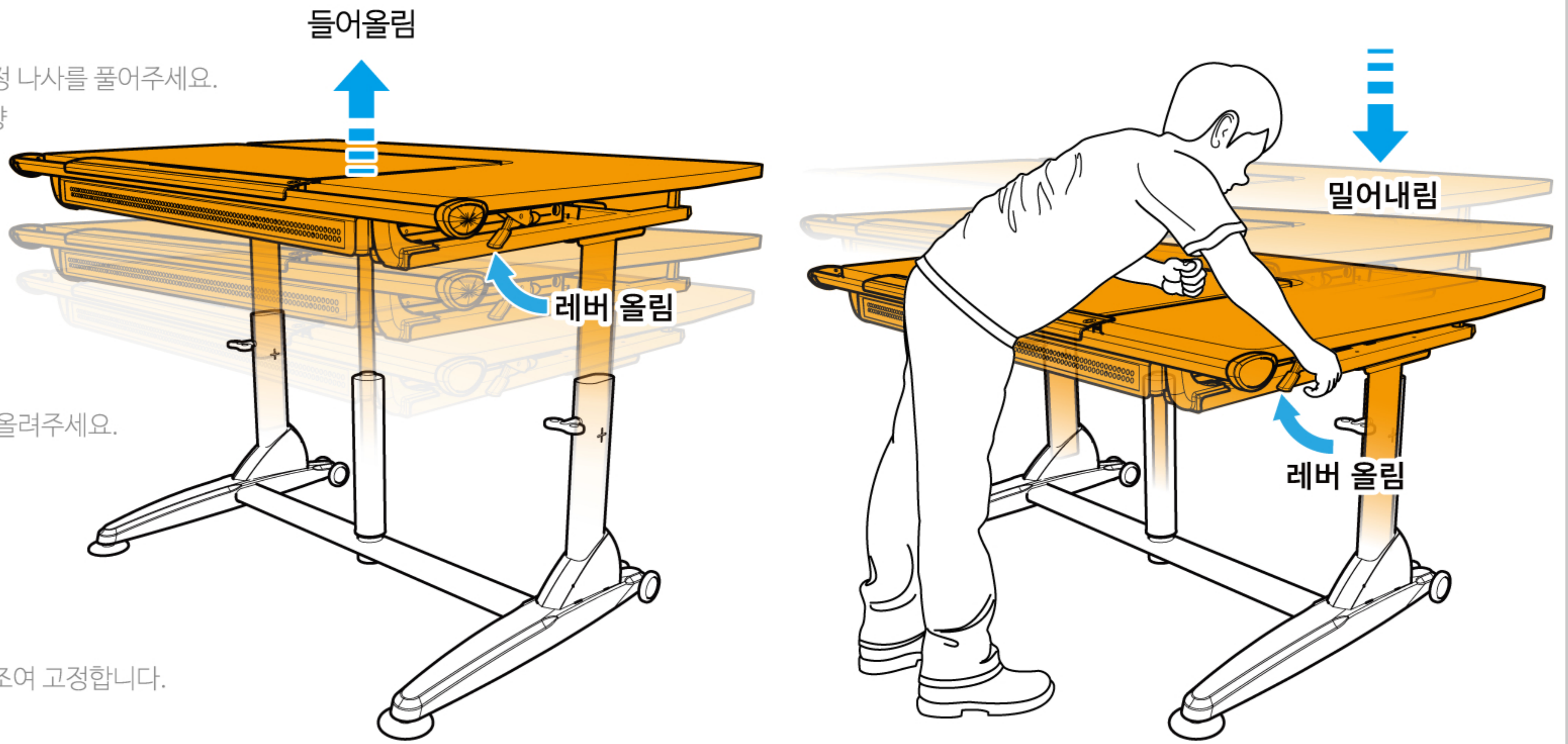

각도 조절

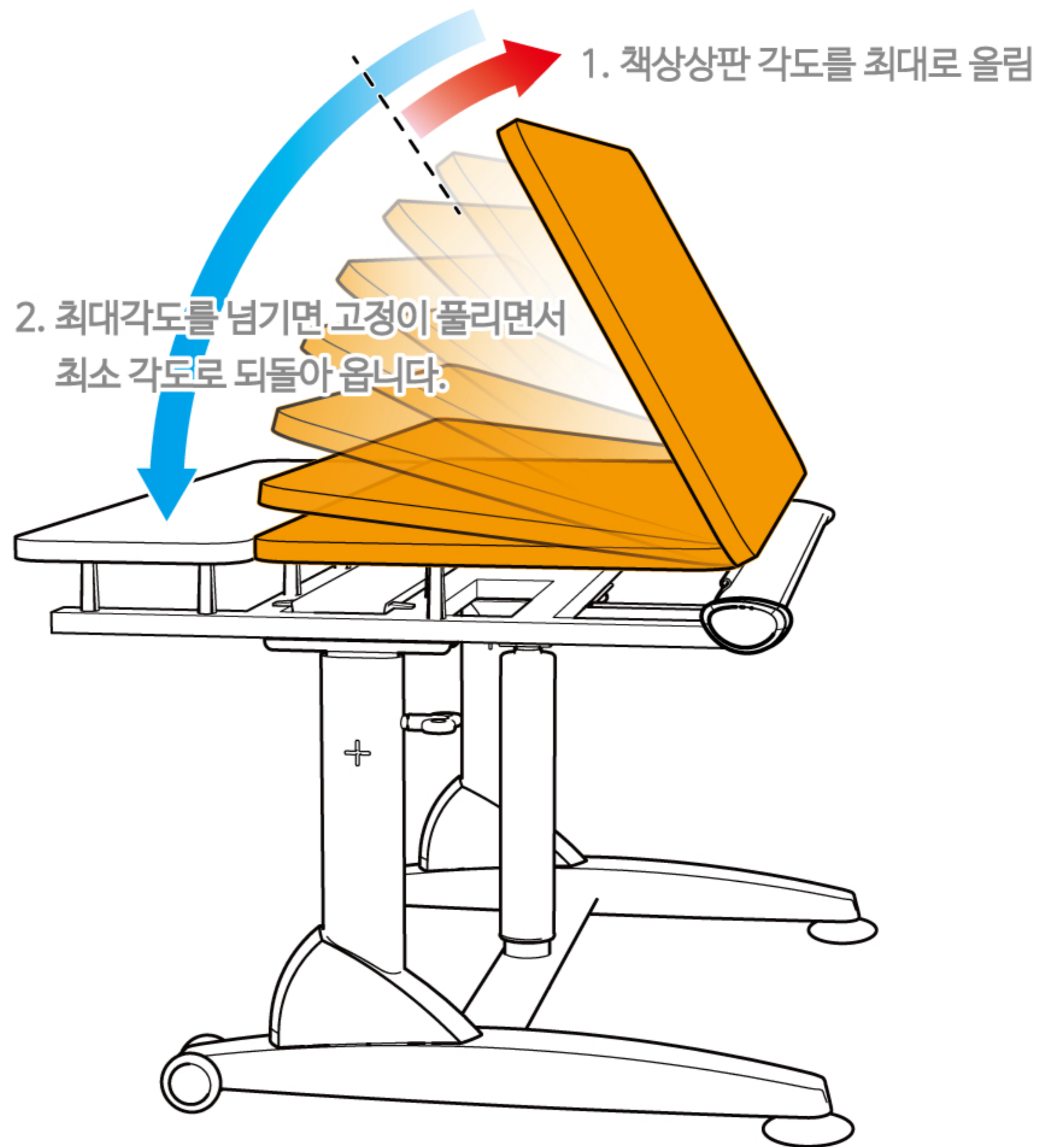
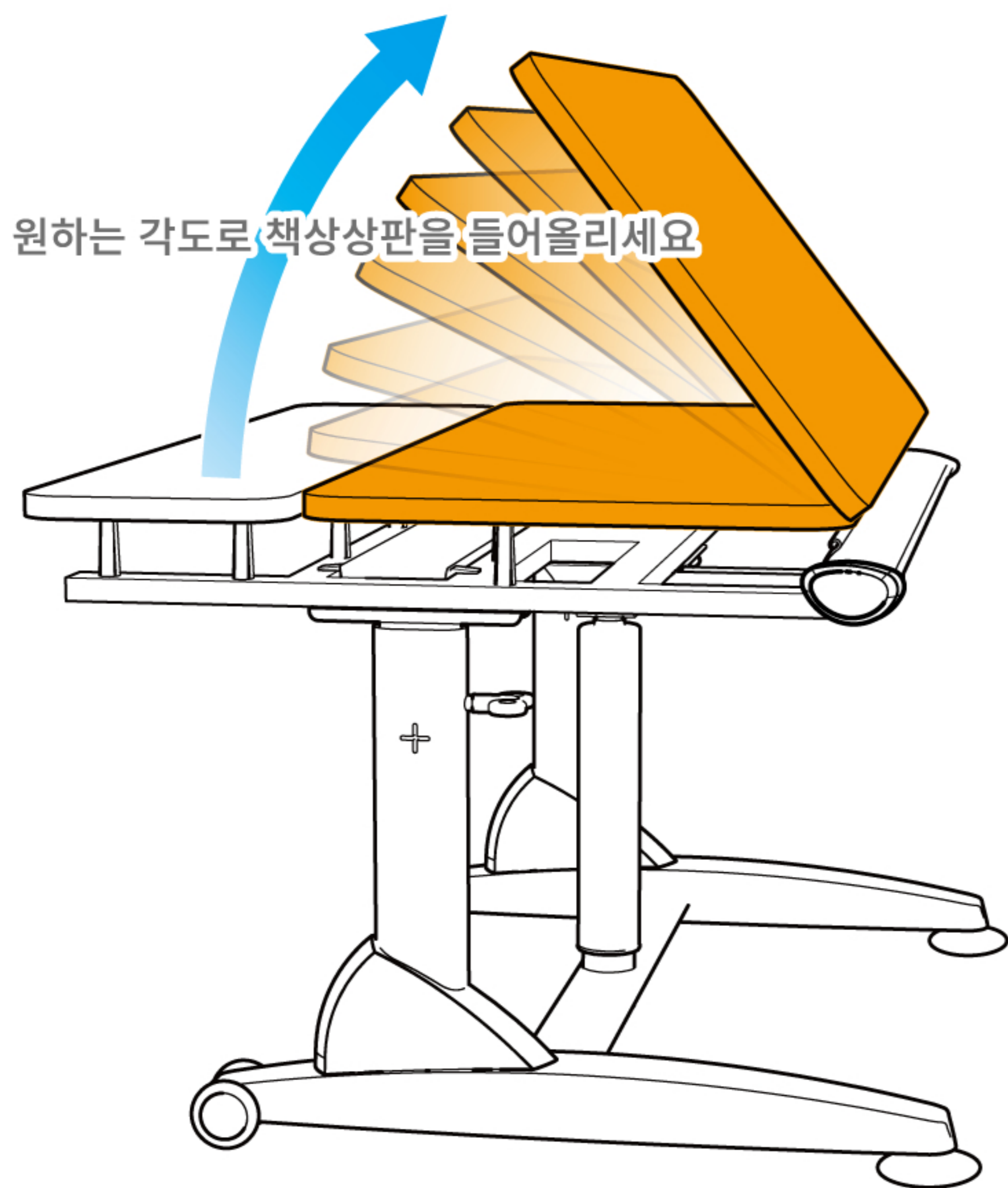

높이, 각도 조절 시 성인이 조작하여 주십시오.



A. 10 + 5 + 1이란 무엇입니까?

모든 Kid2Youth 제품은 제품품질에 대한 확신으로 다양한 부품에 대해 10년, 5년, 1년 보증을 제공하고, 국제 기준의 테스트 및 국제 표준 인증을 받았습니다.

B. 보증 및 서비스

1. Kid2Youth & TCT Dynamic Workstation 공식수입사 를 통해 판매된 제품만 결함을 보증합니다.
2. 결함이 확인 된 후 동일하거나 유사한 제품을 수리 또는 교체 가능합니다.
3. 제품의 결함이 확인 된 경우 수리 또는 교체에 따른 모든 비용은 판매자가 부담합니다.
4. Kid2Youth 공식수입사 허가없이 보증이 적용되지 않습니다.
5. 결함이 있는 제품이 더 이상 생산되지 않을시에는 동일하거나 유사한 제품으로 교체 가능합니다.
6. 서비스는 대만 Kid2Youth & TCT Dynamic Workstation 에서 승인 한 공식수입사에만 제공합니다.

C. 보증 범위

10년 보증 : 독일산 STABILUS 가스리프트. (자세한 내용은 D 항목 참조)

5년 보증 : 기본 또는 보조 구조. (책상, 의자 본체, 캐비닛, 하드웨어. (상세 항목 D 참조).

1년 보증 : 모든 소모품. (PU 휠, 조절 식 다리. 세부 사항은 D 항목 참조).

D. 보증에서 제외되는 경우

1. 구매자에 의한 인위적인 제품 손상, 천재 지변, 기후 (습한) 로 인한 불량은 보증하지 않습니다.
2. 부품의 제거, 자체 수리로 인한 손상은 보증하지 않습니다.
3. 정상적인 상황에서 제품의 색 바램은 보증하지 않습니다.
4. 보증은 샘플, 전시회 및 교차 구매에 대해서는 적용되지 않습니다.
5. 중고 제품 구매자에 대해서는 보증하지 않습니다.
6. Kid2Youth & TCT Dynamic Workstation의 공식수입사 또는 대리인이 발행한 보증 정책이 없는 제품은 보증하지 않습니다.
7. 수정 권한은 언제든지 Kid2Youth & TCT Dynamic Workstation에 있습니다.

E. 유지 보수 안내서

1. 조립설명서와 사용 매뉴얼을 충분히 숙지하시고 사용하세요.
2. 임의로 분해는 금지되어 있습니다.
3. 정기적으로 연결부와 조절부를 점검하고 윤활하는 것이 좋습니다.
4. 가스 리프트 시스템이 원활하게 움직이도록 정기적으로 높이를 변경해주세요.
5. 정기적으로 나사를 확인하여 풀어진곳이 있으면 조여서 사용하세요.
6. 부식성이 있는 세척제와 거친수세미등의 직물의 사용을 금합니다. 제품을 항상 건조하게 유지하십시오.

문제 해결

책상상판의 높이 조절에 문제가 있습니까?

- 한쪽으로 책상의 무게가 치우쳐져있지 않은지 책상상판이 측면으로 기울어져 있지않는지 확인하십시오.
- 책상이 놓여진 지면이 수평인지 확인하세요.
- 위에서 언급한 내용을 해결했지만 문제가 남아 있을경우 모든 나사를 반쯤 풀도록 제안합니다.
대칭 위치의 나사를 하나씩 조입니다.
모두 시도한 후에도 문제가 지속되었으면 더 나은 솔루션을 위해 대리점이나 유통 업체에 문의하십시오.

책상상판 각도 조절이 작동하지 않습니까?

- 오일로 윤활하여 잡티가 떨어져 나가도록 하세요.

긴 시간 사용 후 책상상판 높이조절에 문제가 생겼나요?

- 한쪽으로 책상의 무게가 치우쳐져있지 않은지 확인하고 요인을 제거하거나 무게중심을 제품중앙으로 맞추세요!
- 책상에 적제되어있는 물건을 꺼내십시오. 와이어 컨트롤을 당김과 동시에 책상상판을 들어 올리십시오. 몇번씩 반복하십시오.



Инструкция по сборке G2C+/G6+/G6C+



ВНИМАНИЕ

- Использование стола только для детей от 4 лет.
- Сборка осуществляется взрослым.
- Рекомендуется эксплуатация в присутствии родителей.

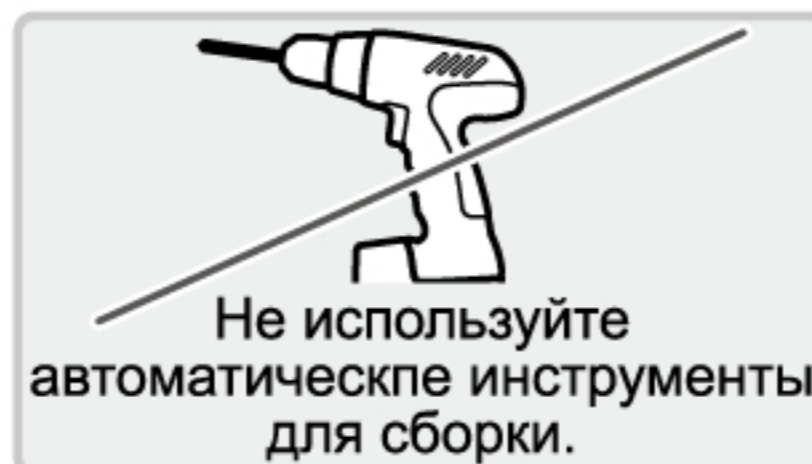

1 Столешница

G2C+ | XXS
XS

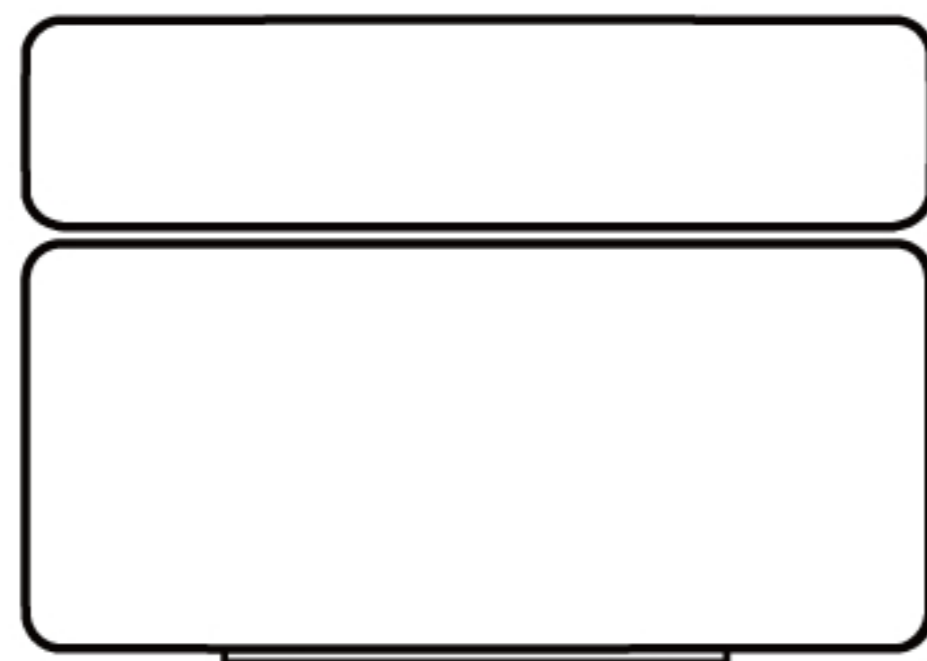

G6+ | XS
S

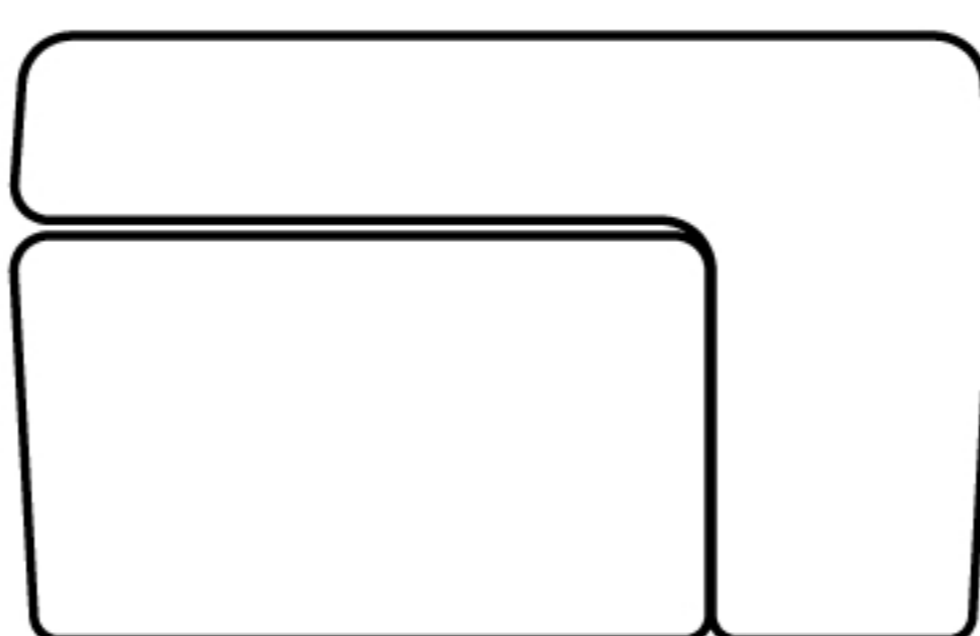

G6C+ | XS
S

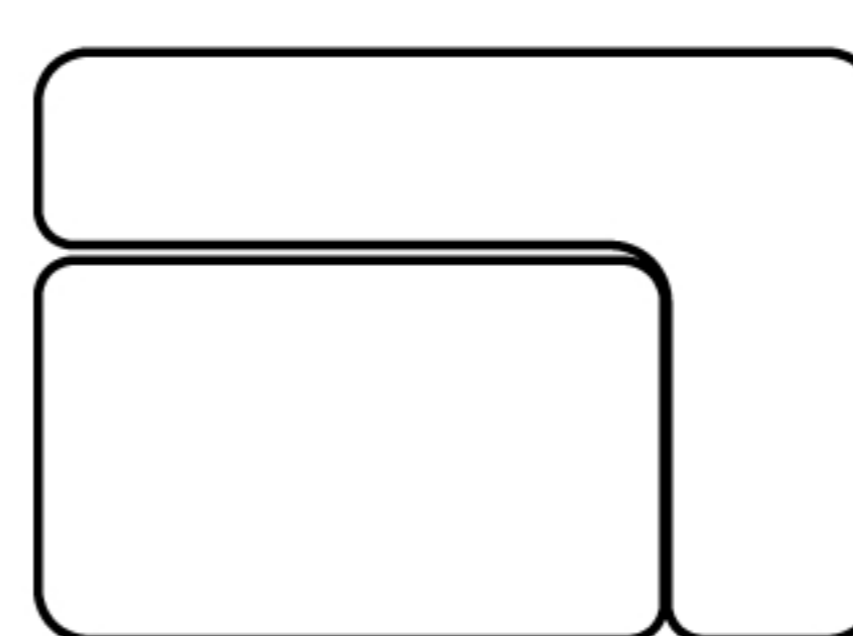

2 Гидравлический амортизатор

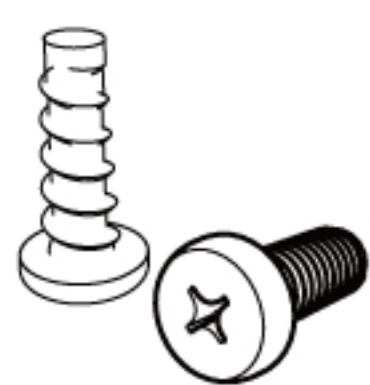

Винты Н
4.8*14mm

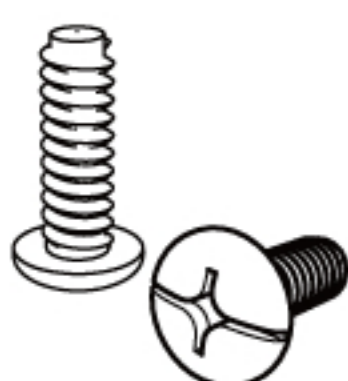
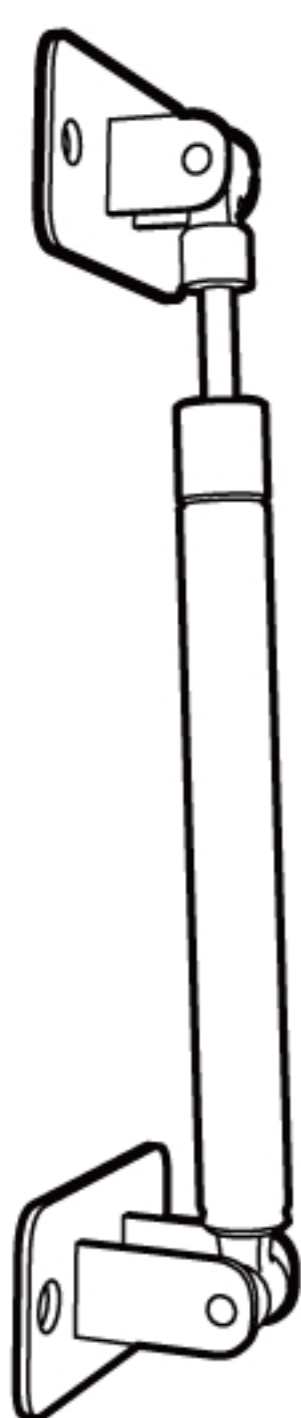

Винты Е
M4*12mm

3 ножка

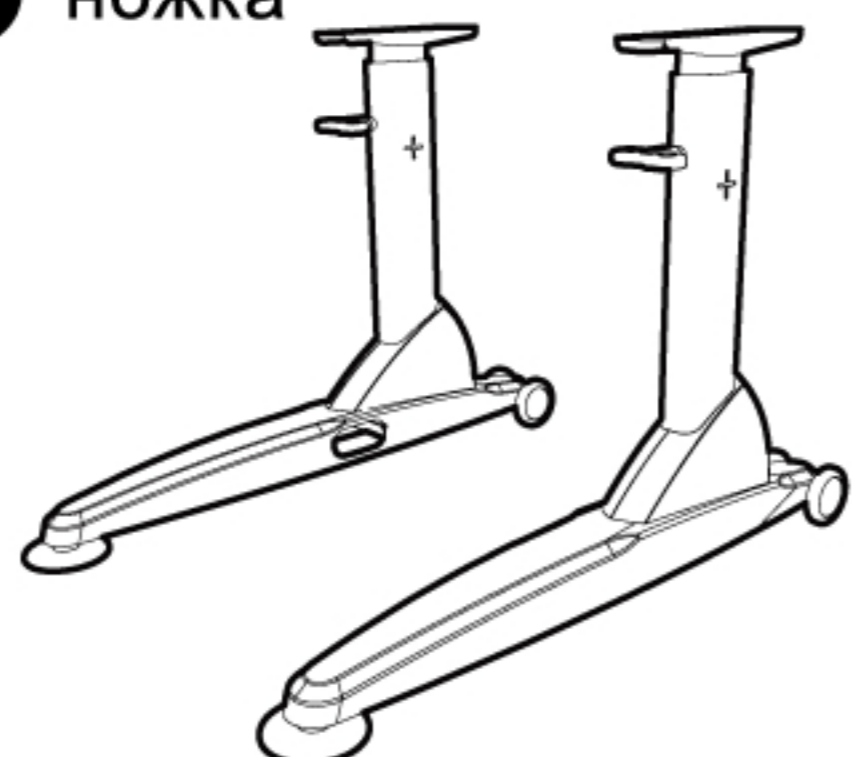

4 Нижняя горизонтальная планка



5 Монтажная пластина

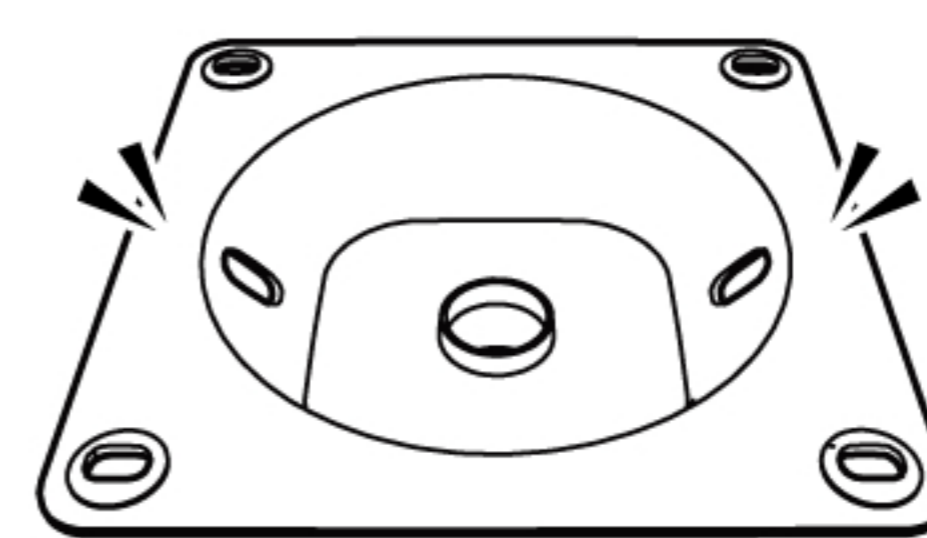

6 Газ-лифт

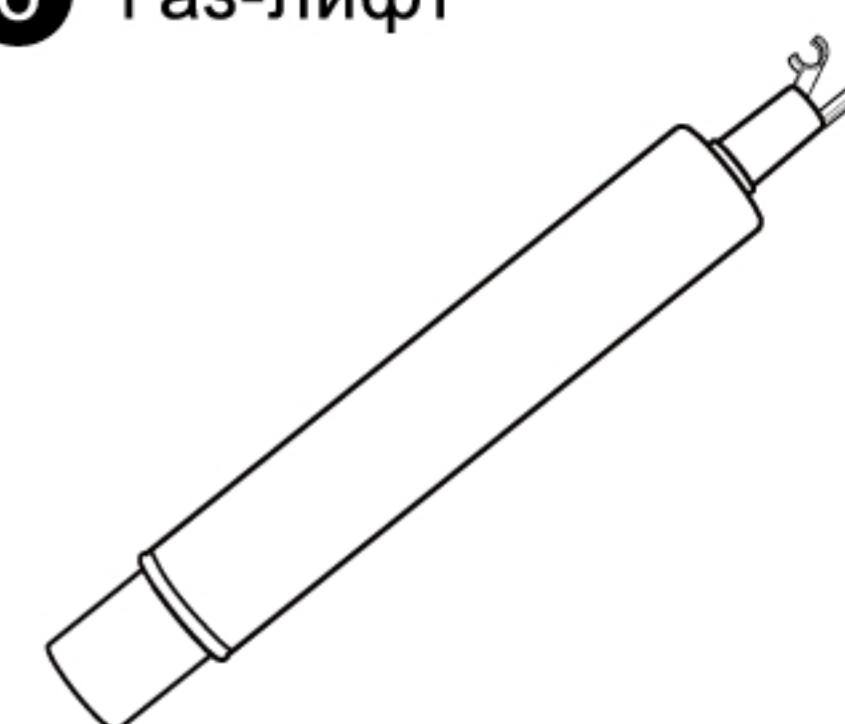

7 Тросовый регулятор

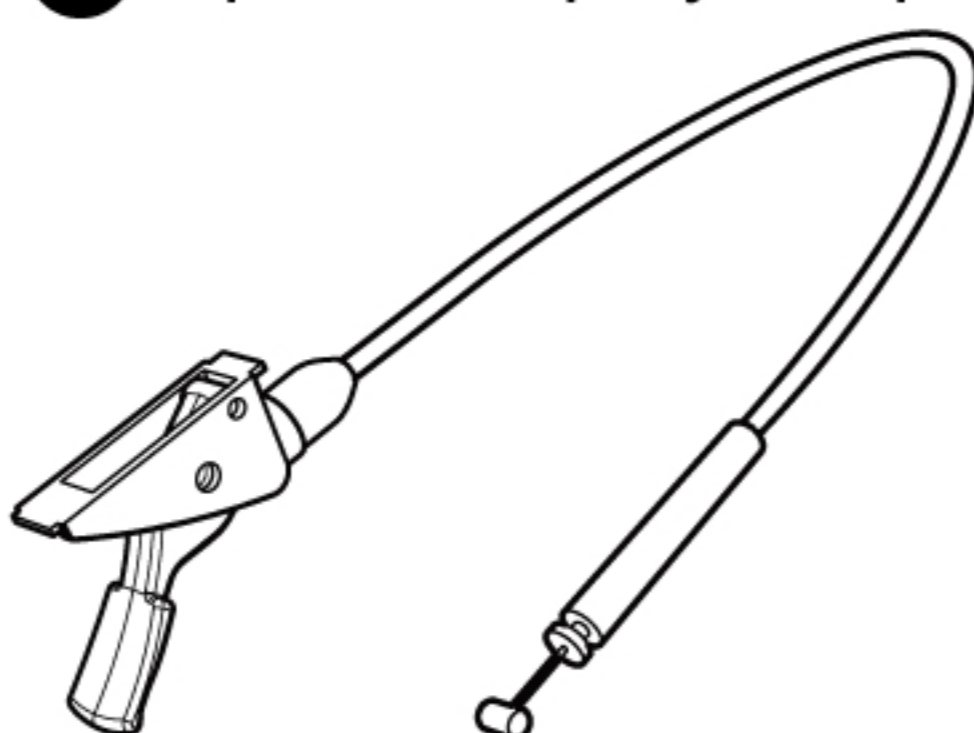

8 Кабельный органайзер S

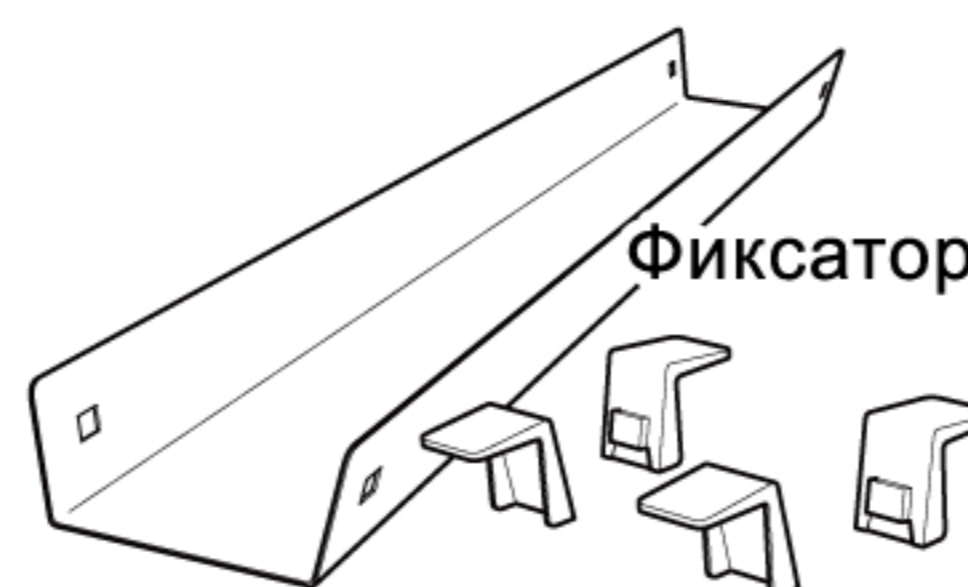

9 Линейка и опора для запястья

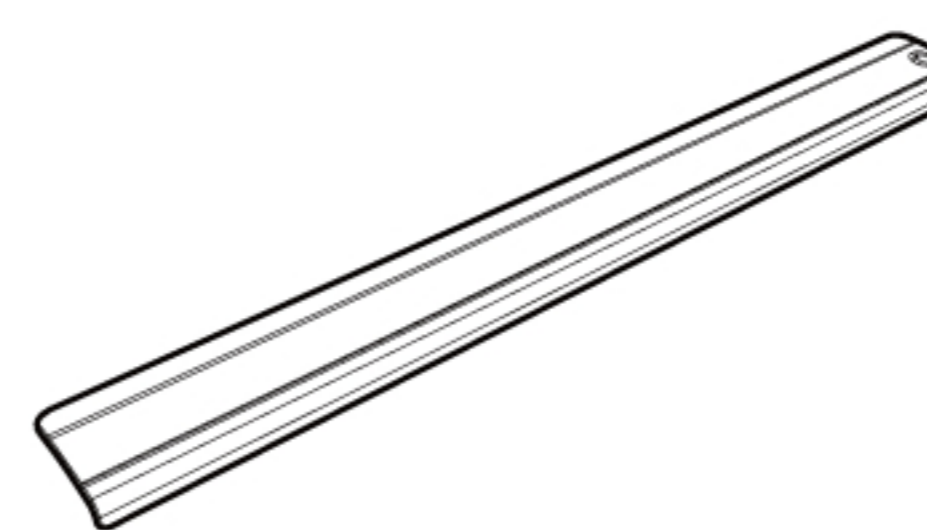

Комплекты деталей

A Винты X 4

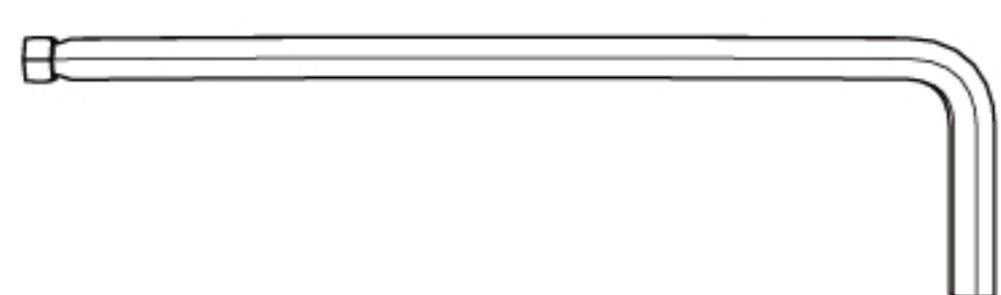

Шестигранник № 4

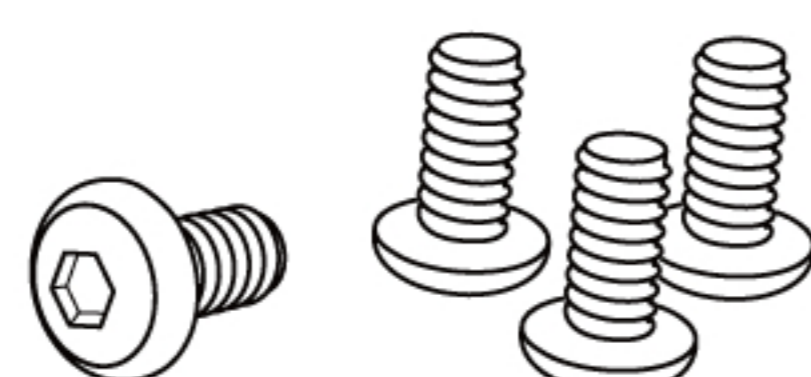

1/4*15mm

A Винты X 4
B шайбы X 4



1/4*15mm

C Винты X 4
D шайбы X 4



M8*38mm

1

Сначала вытащите лоток для принадлежностей. Совместите гидравлический амортизатор 2 с резьбовыми отверстиями, затем туго затяните винты Н и Е.

Обращайте внимание на направление

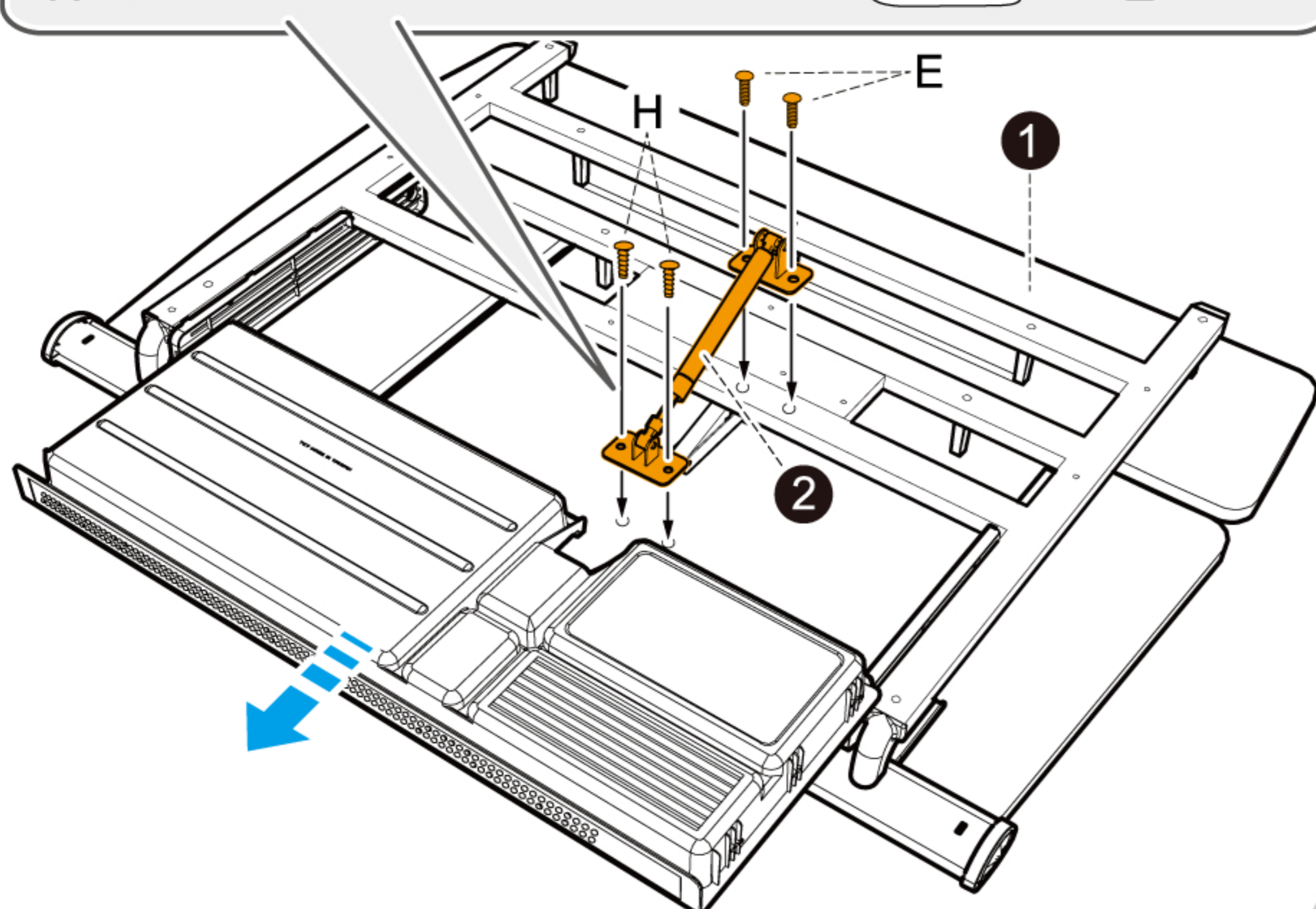
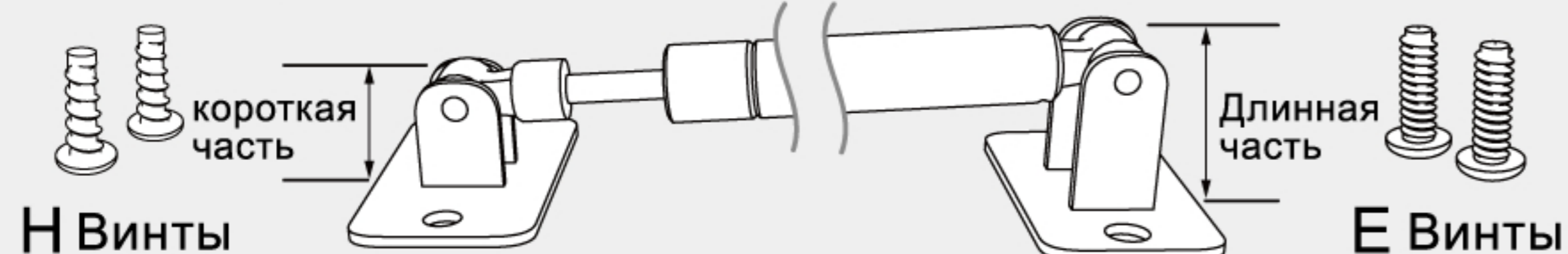

2

Вставьте монтажную пластину 5 в газ-лифт 6. Установите тросовый регулятор 7 на монтажную пластину 5.

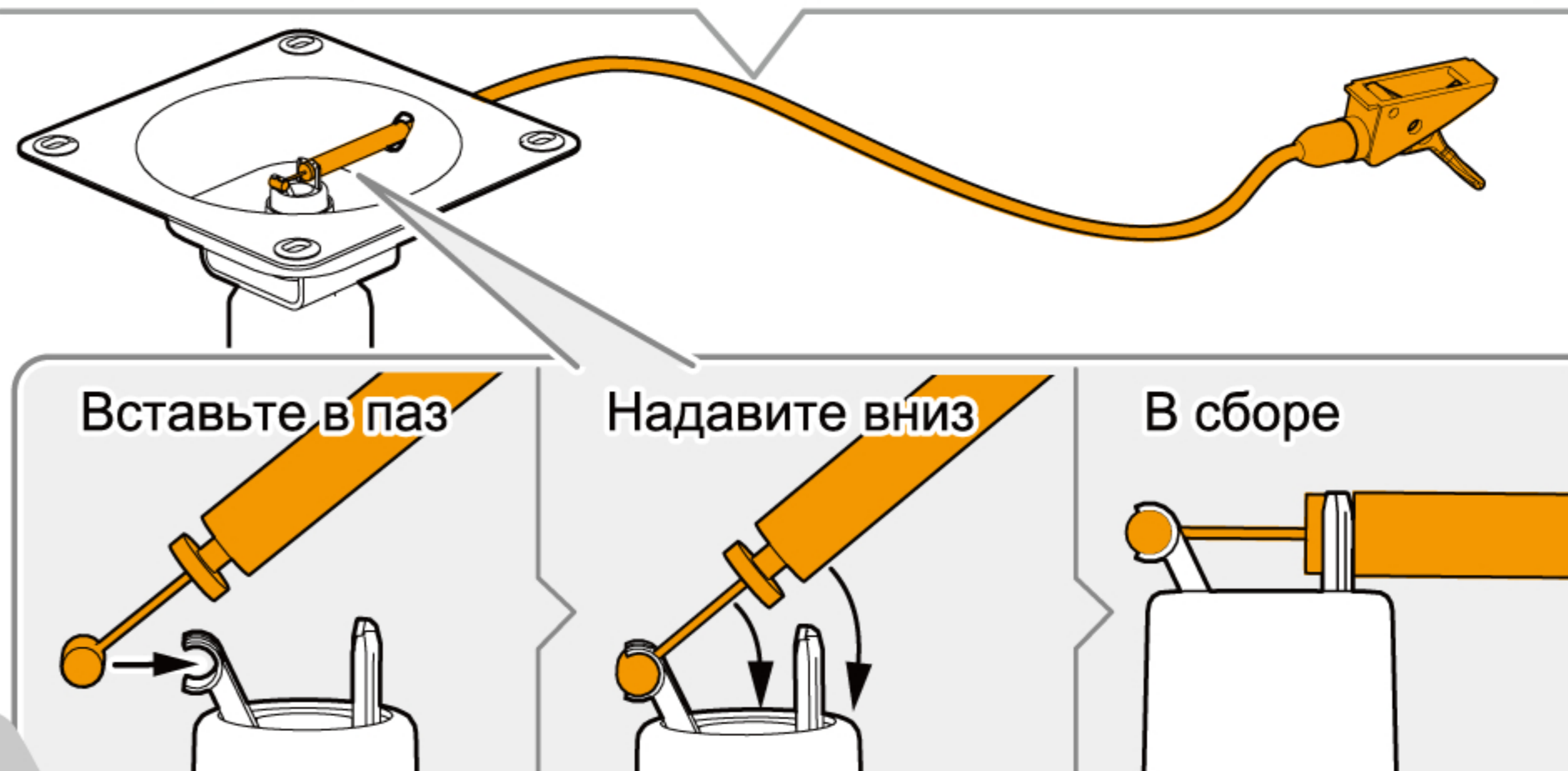
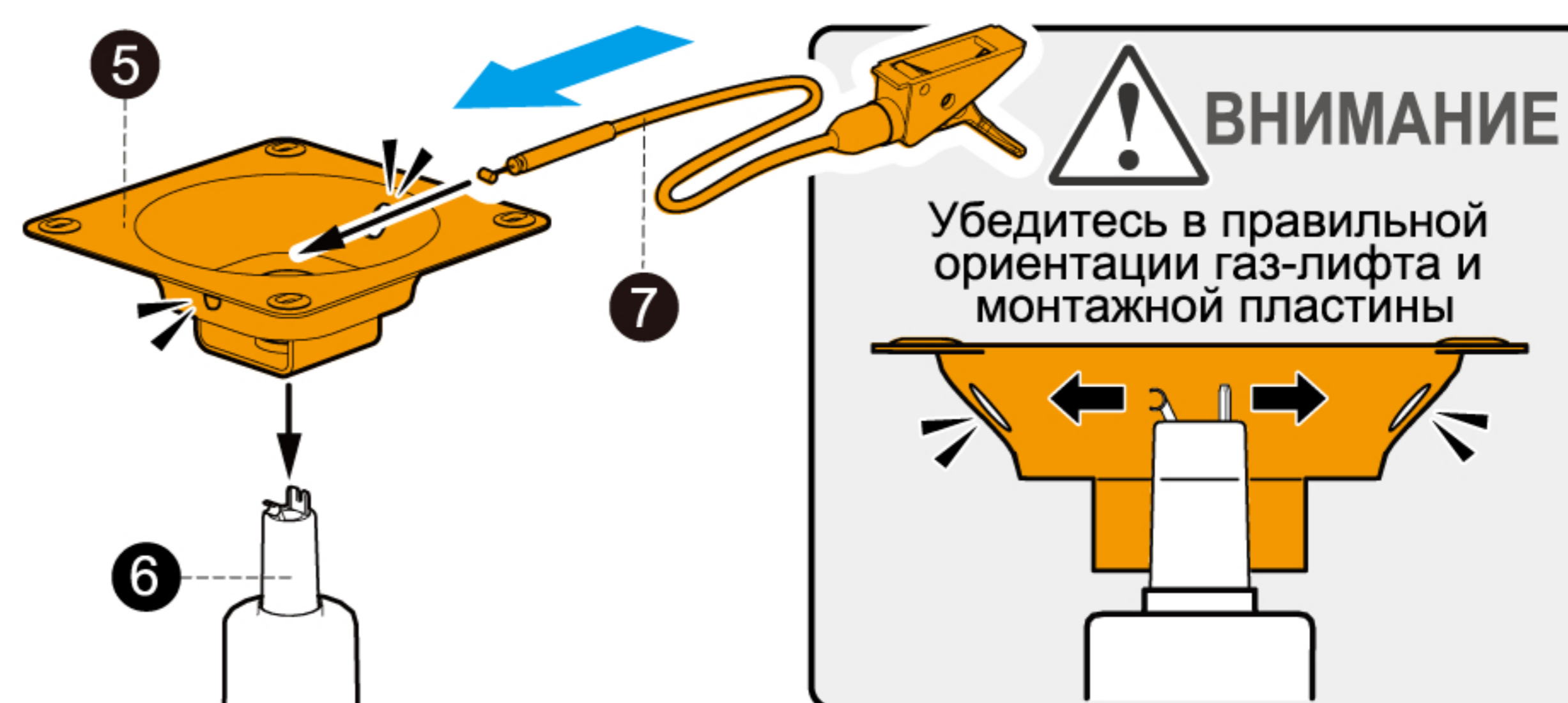

3

Затяните винты А / В / Е в указанном порядке

Запас зазора

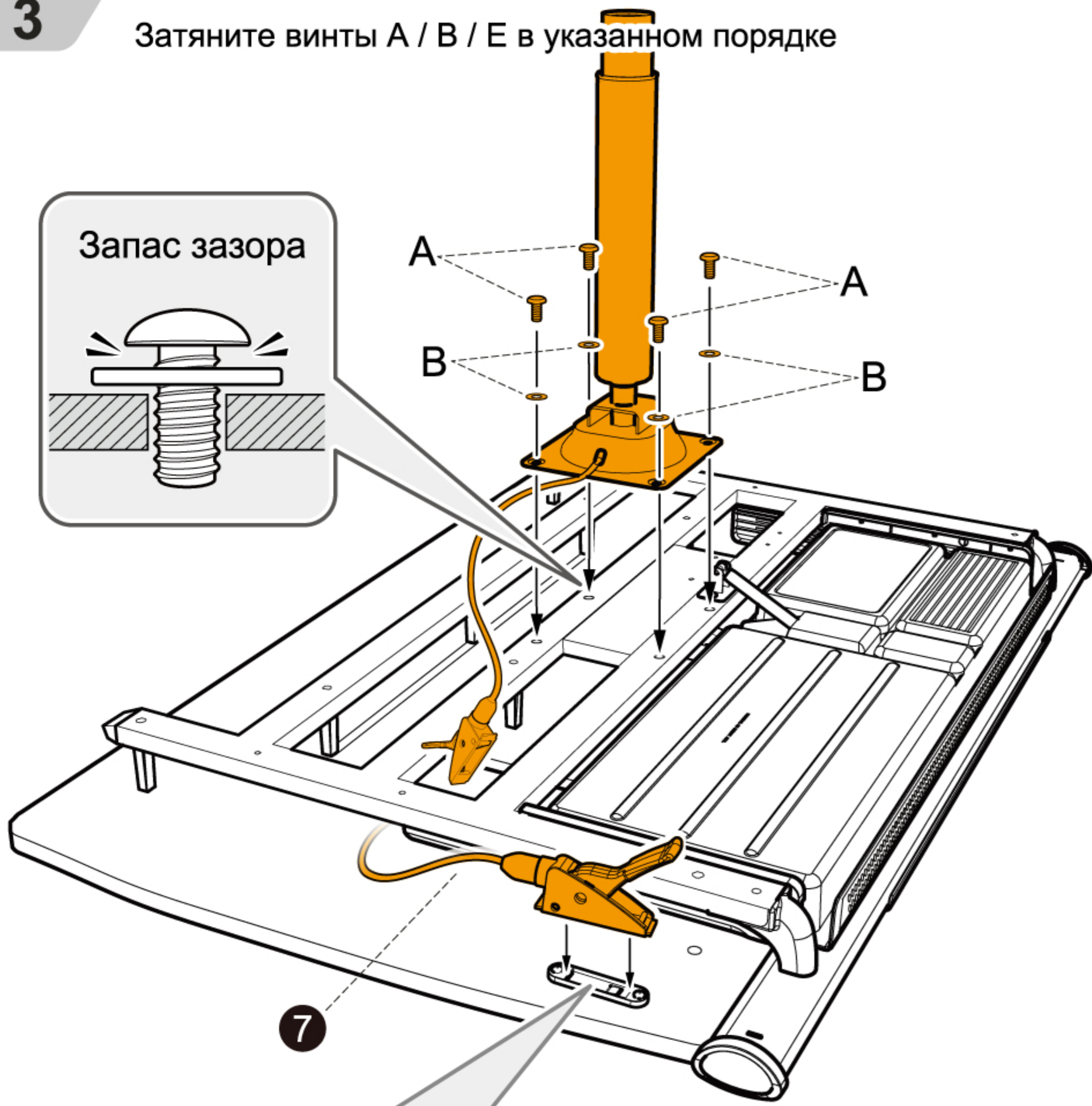
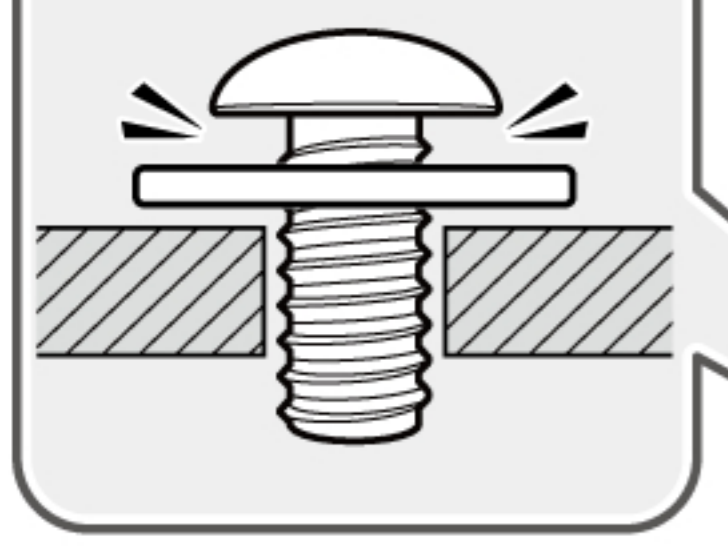

Вставьте в паз

Надавите вниз

Оттяните назад и туго затяните

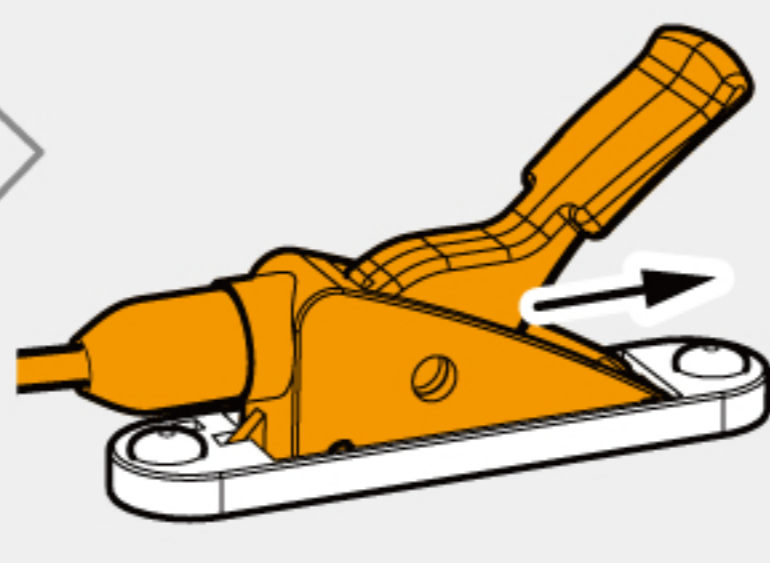
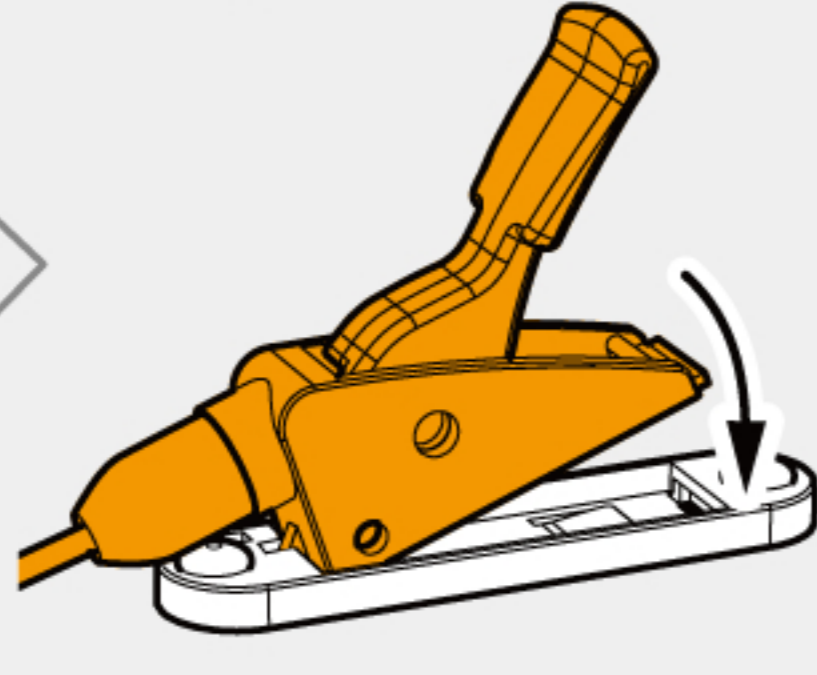
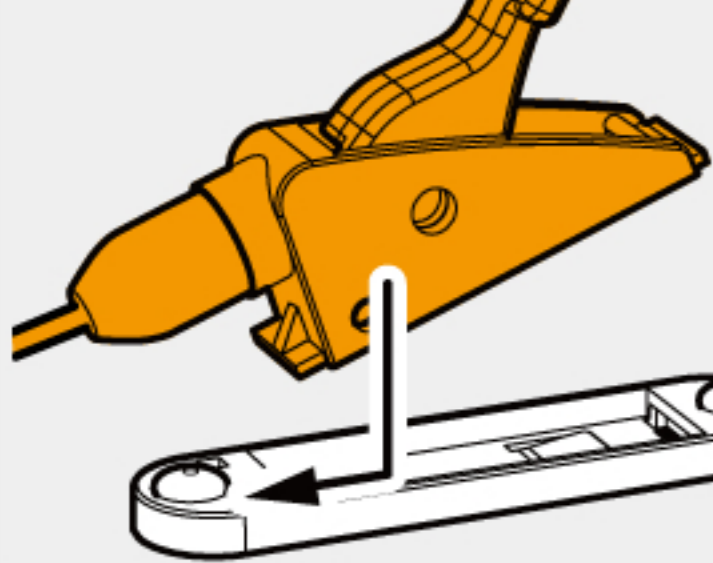

5

Проверьте степень затяжки



ВНИМАНИЕ

Проверьте горизонтальность ножек

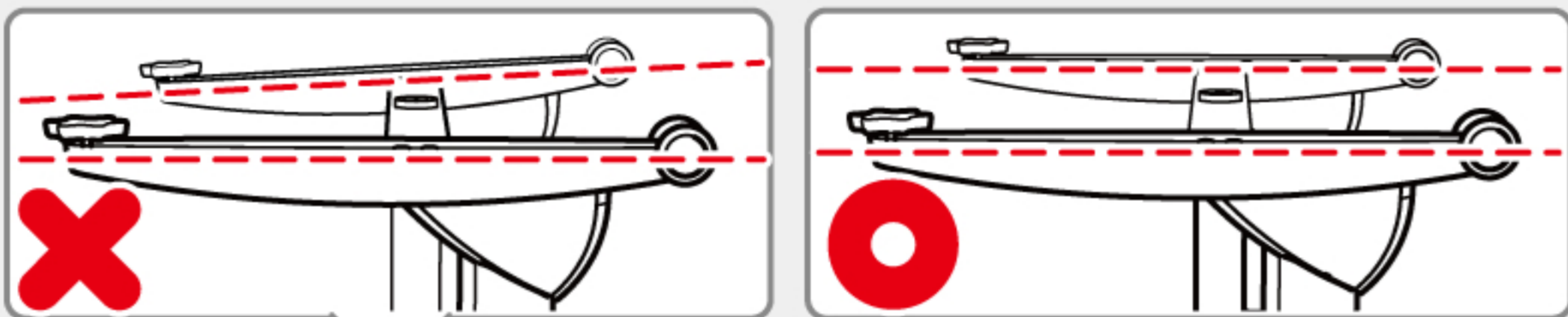

Если ножка стола не выравнивается Шестигранник № 4

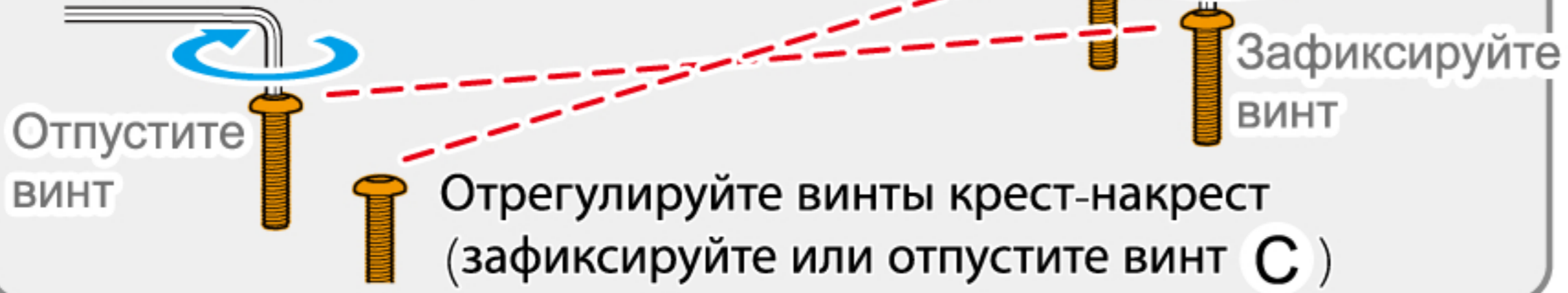

Затяните винты С / D в указанном порядке

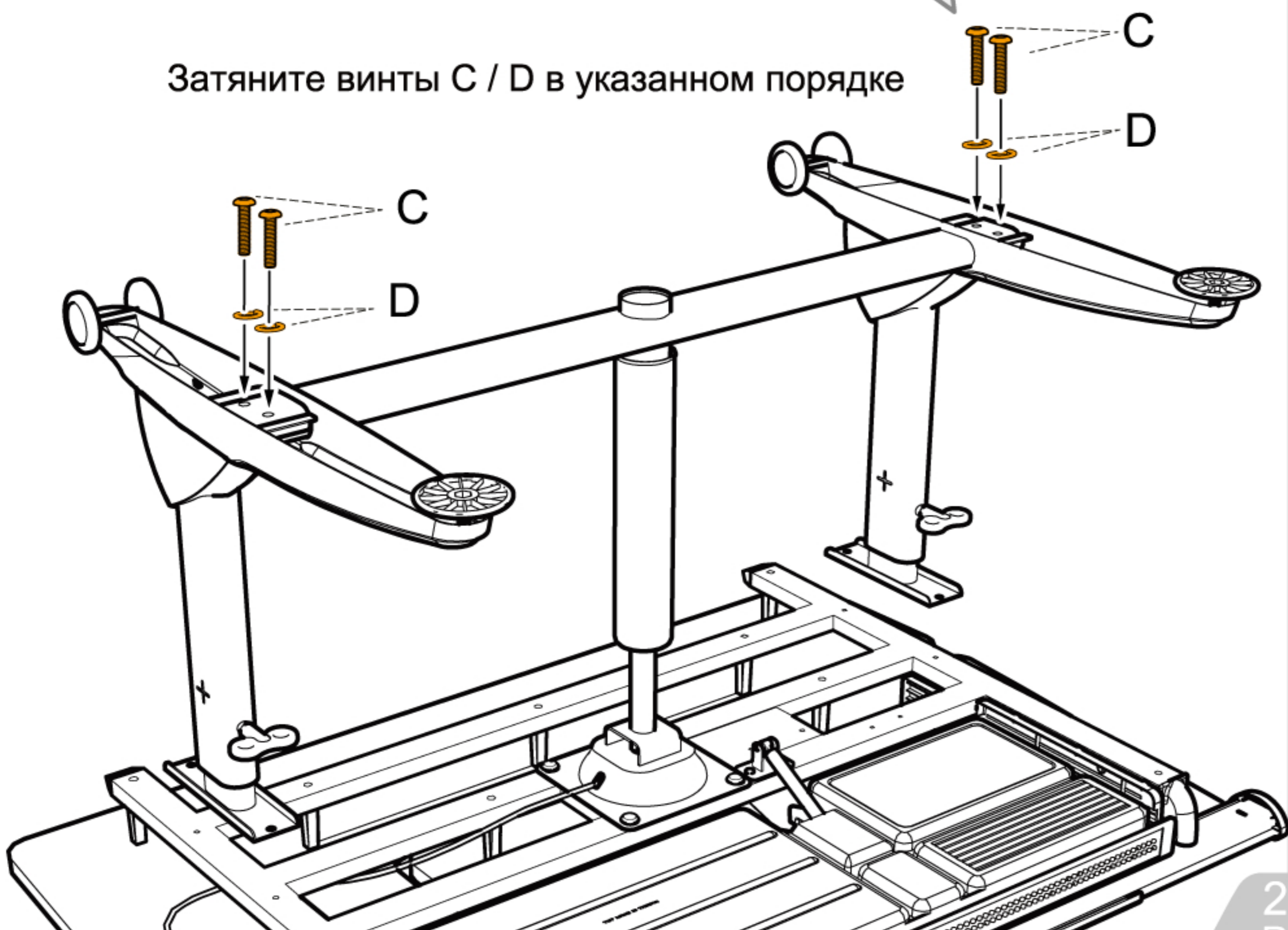

4

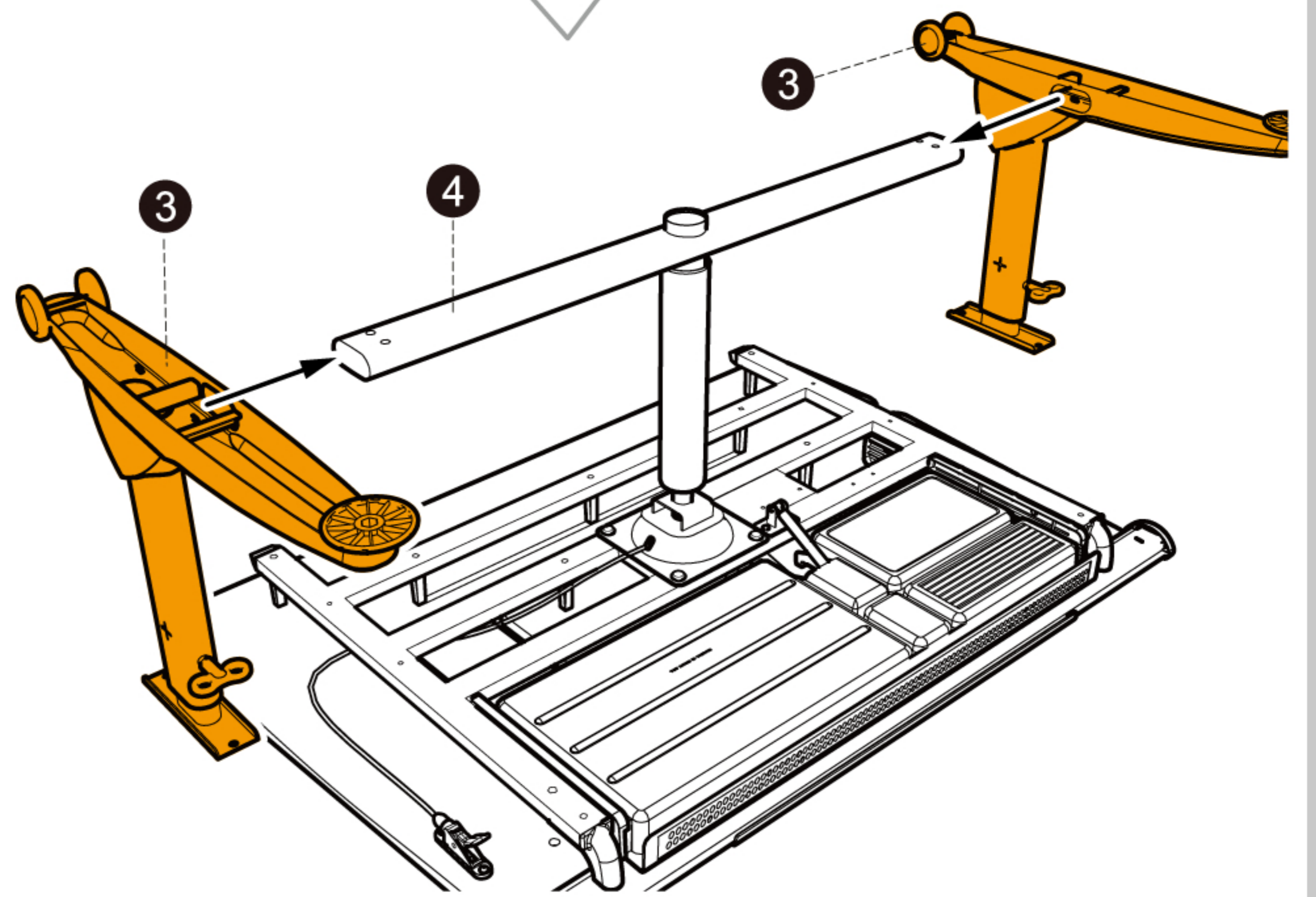
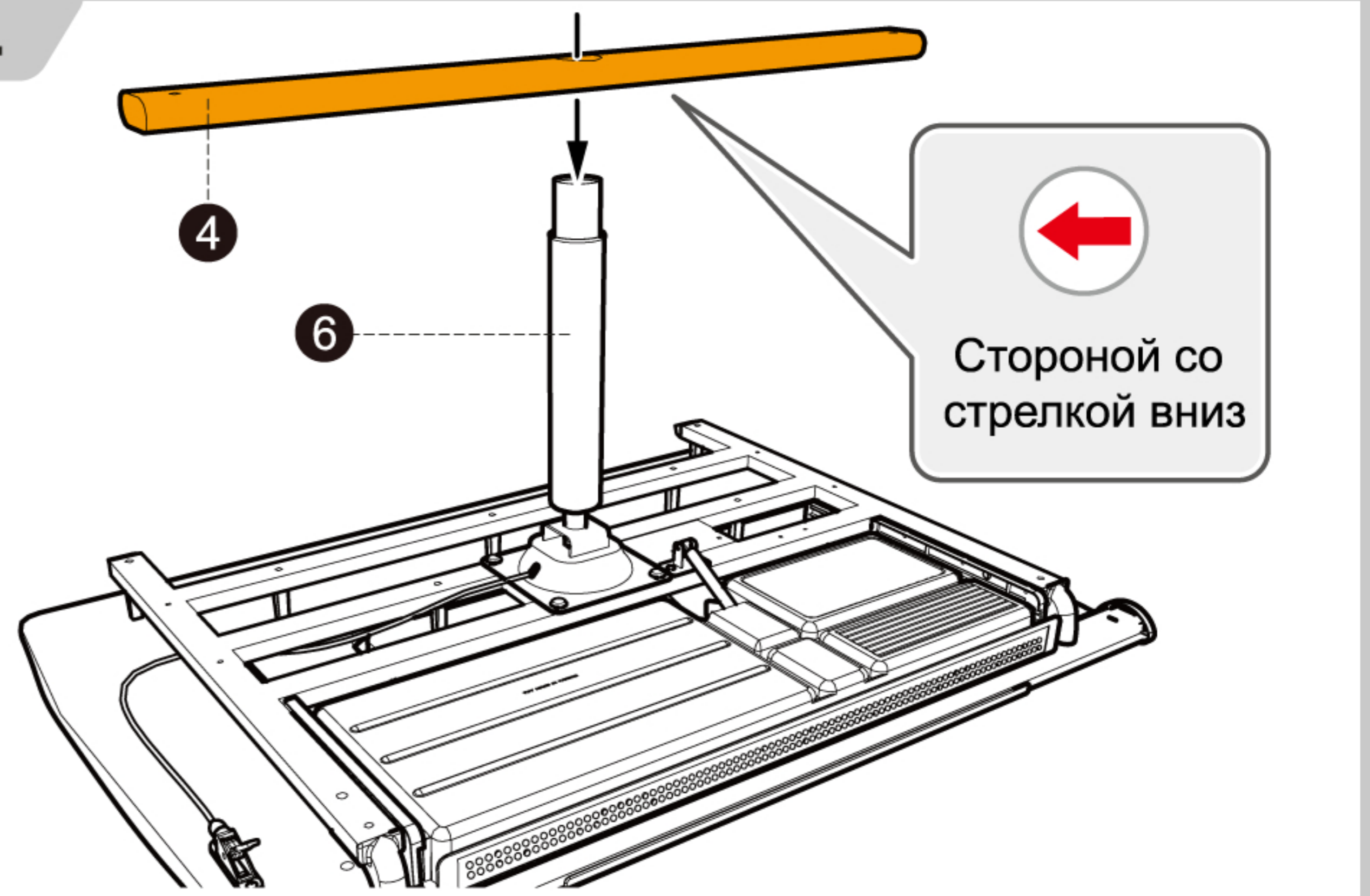

6

Шаг1. Открутите фиксаторы ножек.

Шаг2. Удерживайте внутренние трубки ножек.

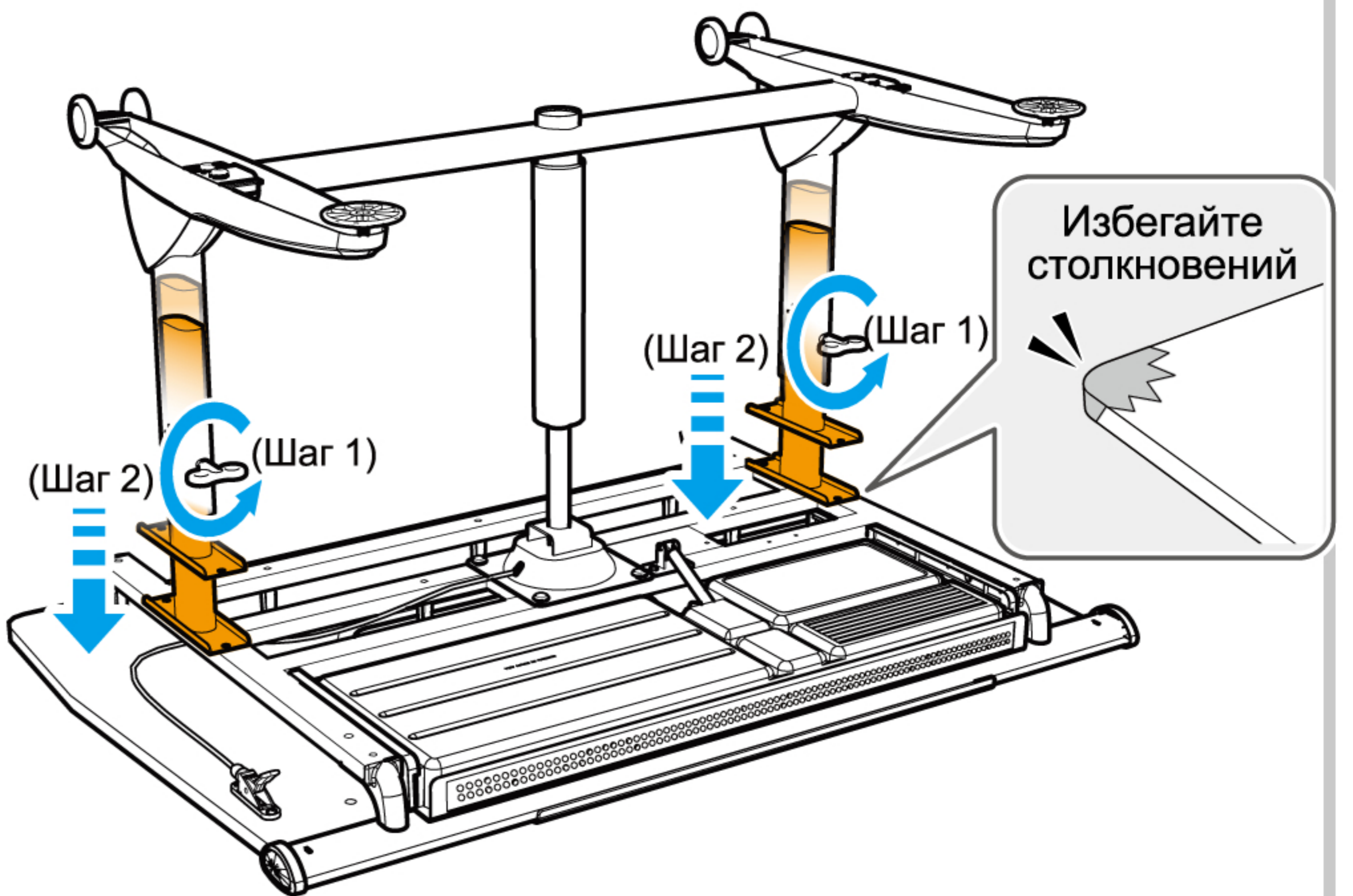

Вкрутите винт А, оставьте зазор

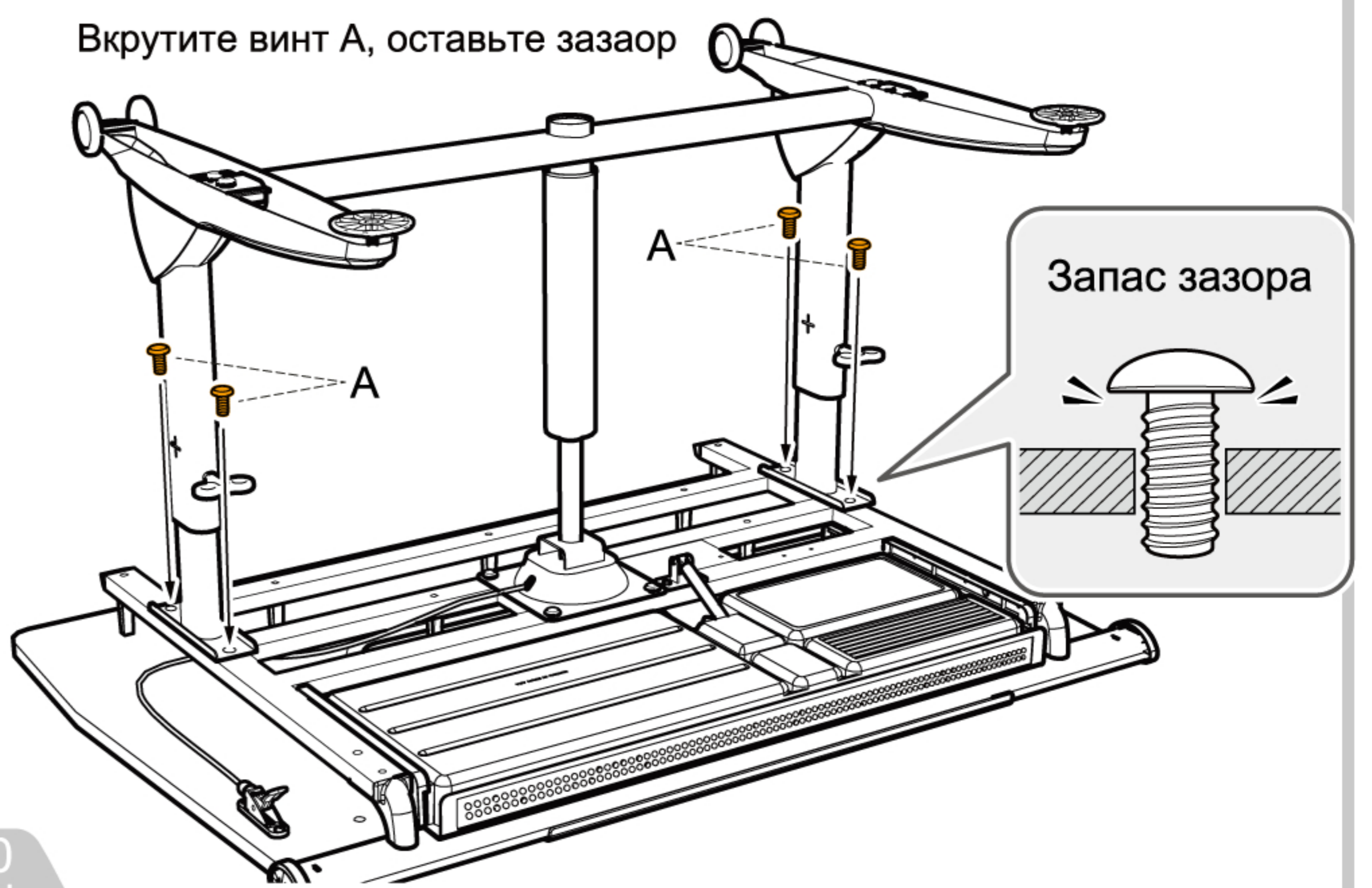

7

Шаг1. Потяните за тросовый регулятор, опуская и поднимая его до тех пор, пока пара не будет стоять ровно.

Шаг2. Затяните все наживленные винты.

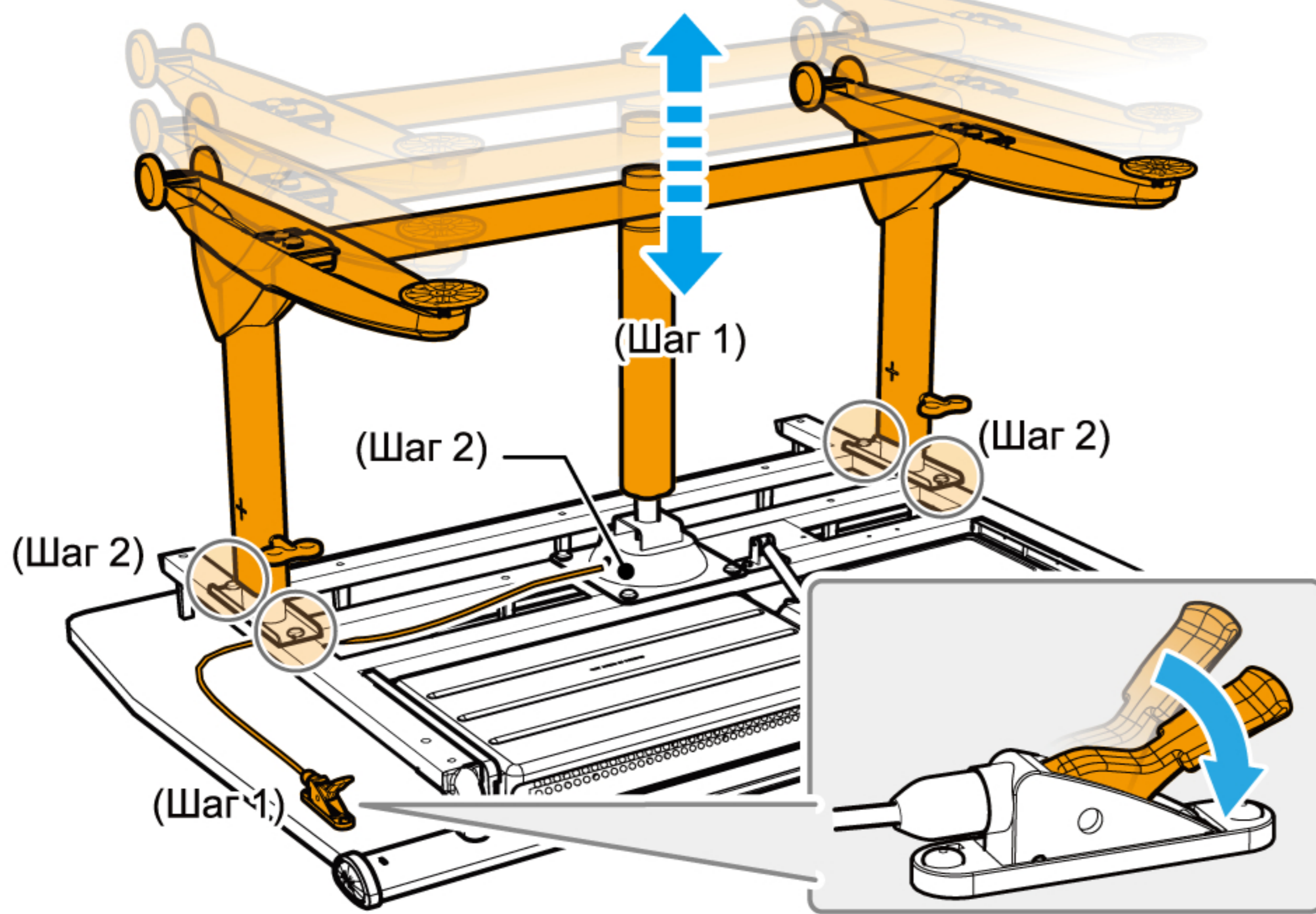

8

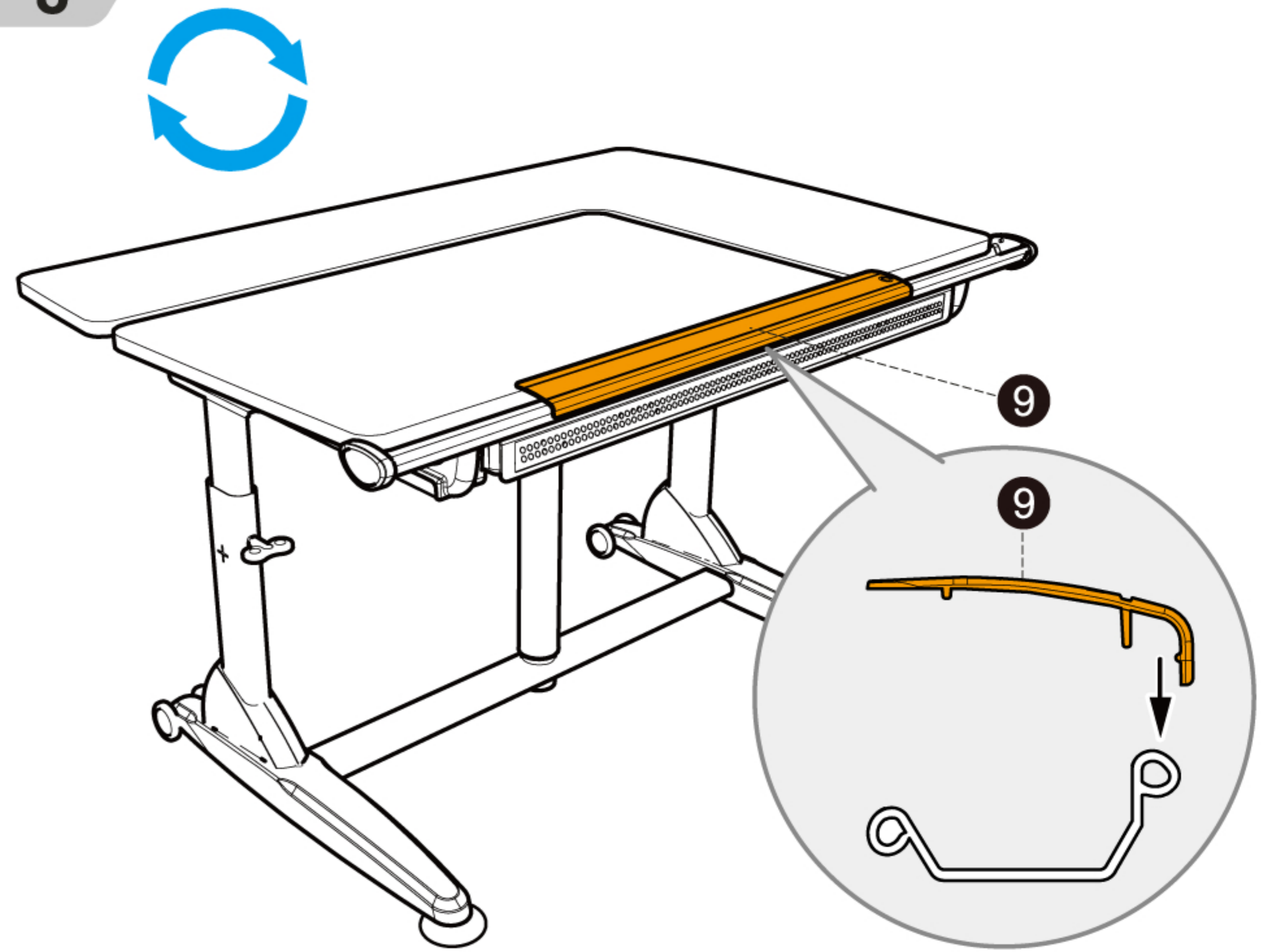

ВНИМАНИЕ

Нагрузку на рабочий стол распределяйте равномерно.



Если рабочий стол перегружен, отрегулируйте высоту руками.



Инструкция

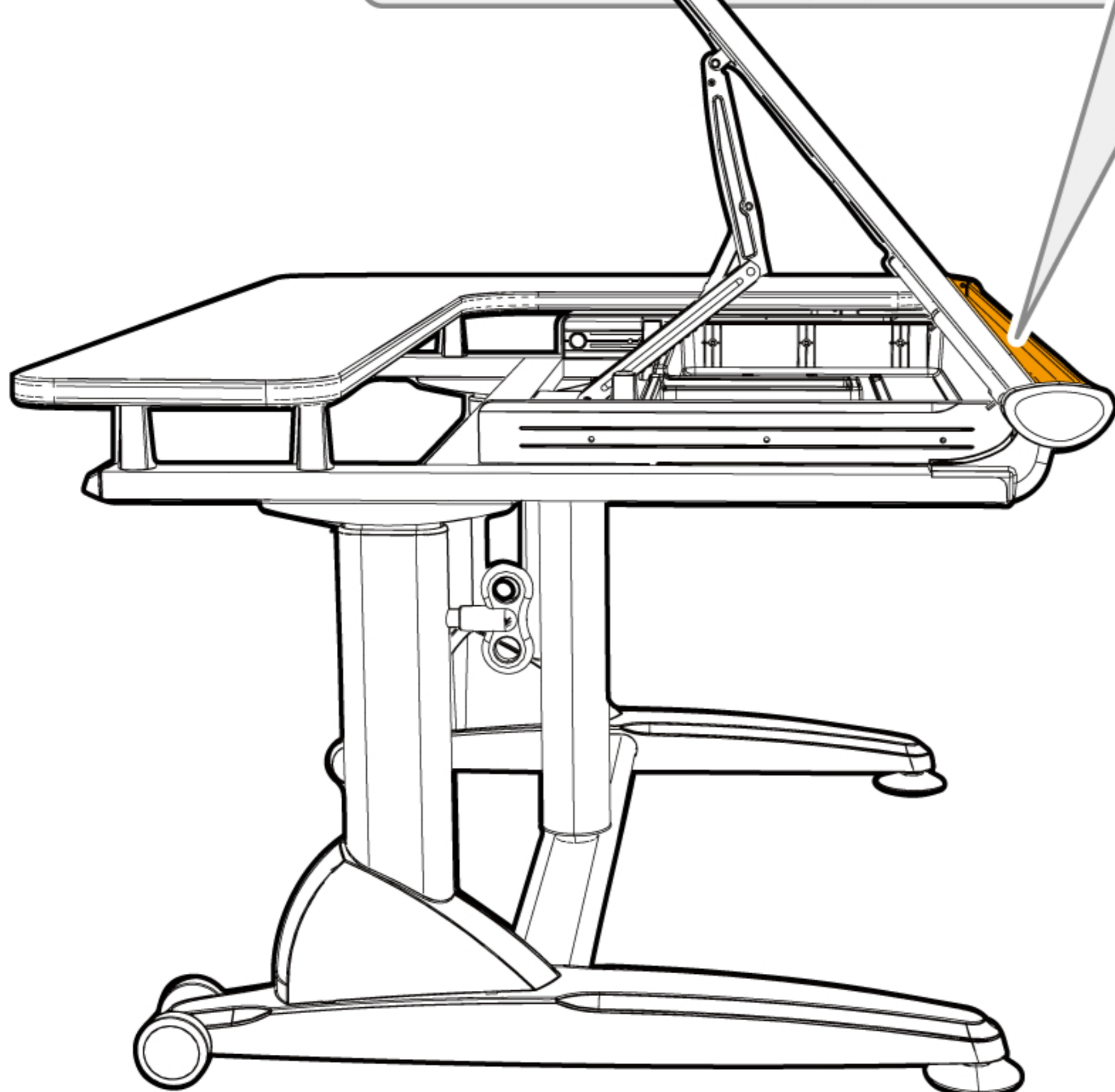

Чтобы вернуть столешницу в горизонтальное положение, поднимите столешницу до максимального верхнего положения и отпустите вниз; не давите, столешница плавно опустится.

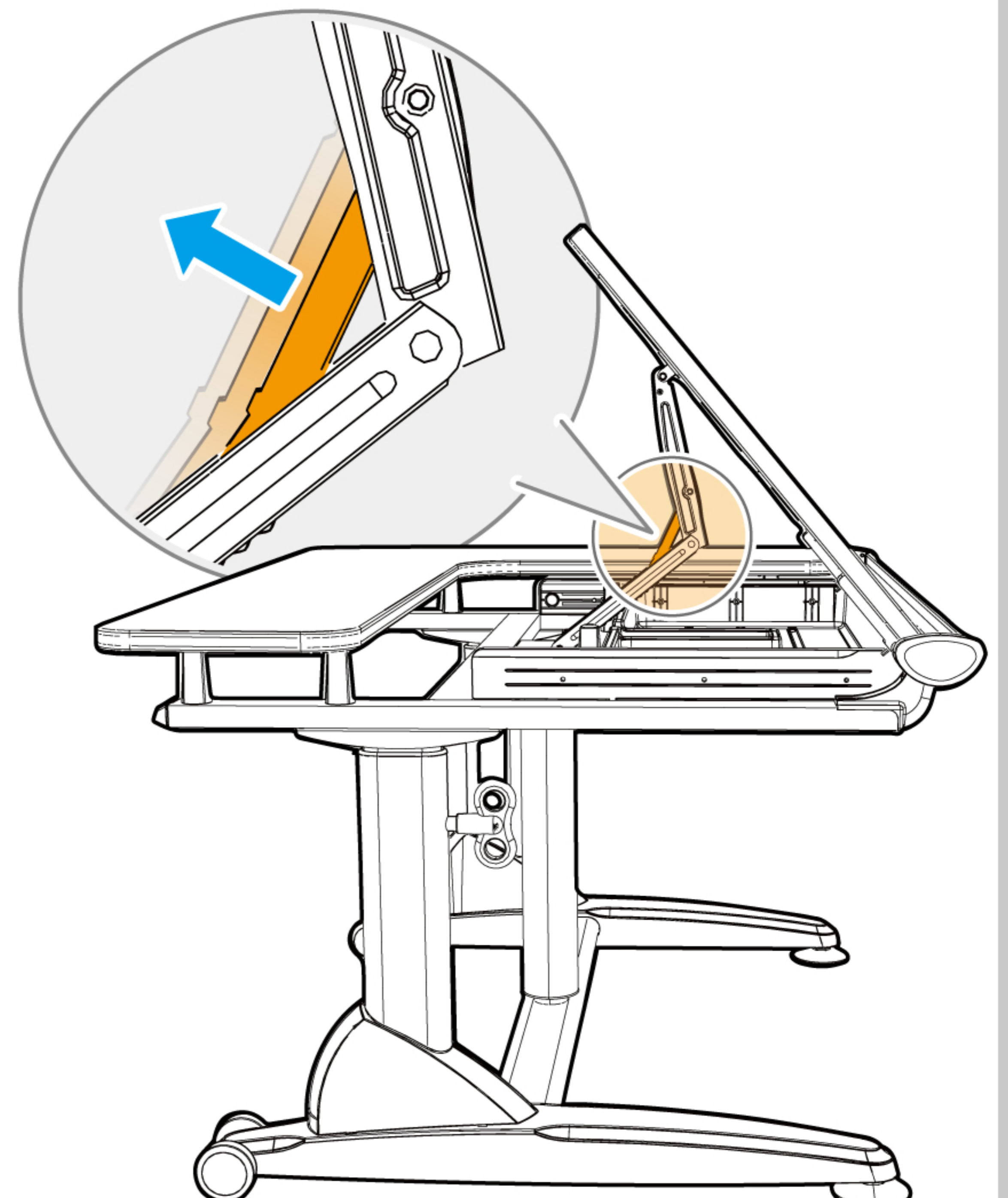

Регулировка высоты

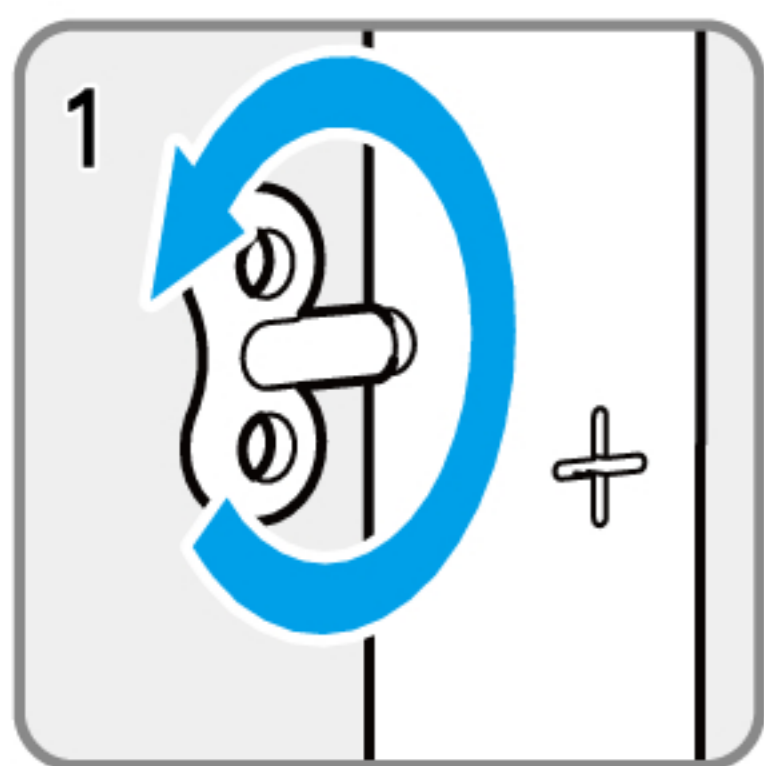

Ослабьте крепление ножки

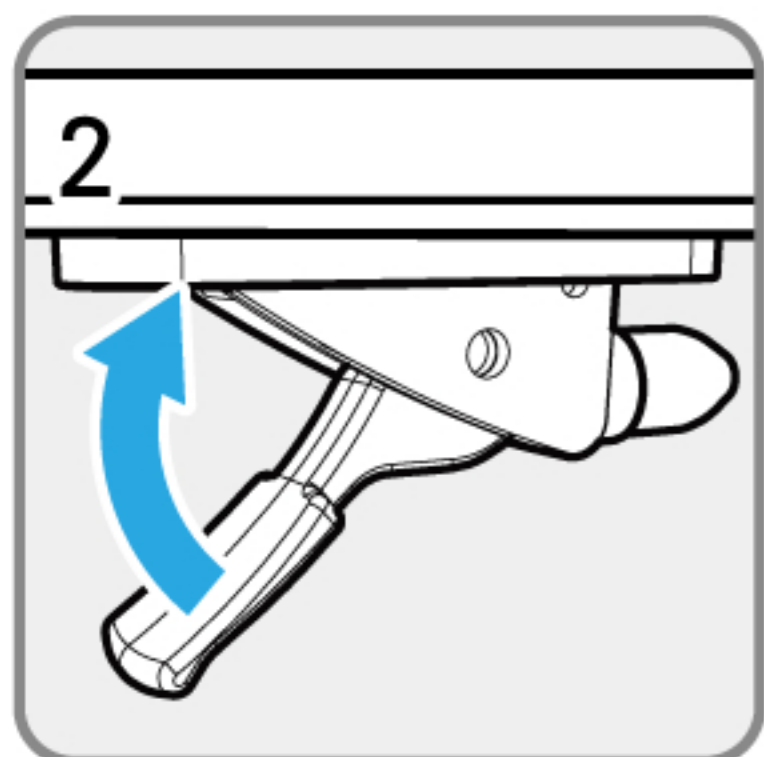

Потяните при помощи рычага

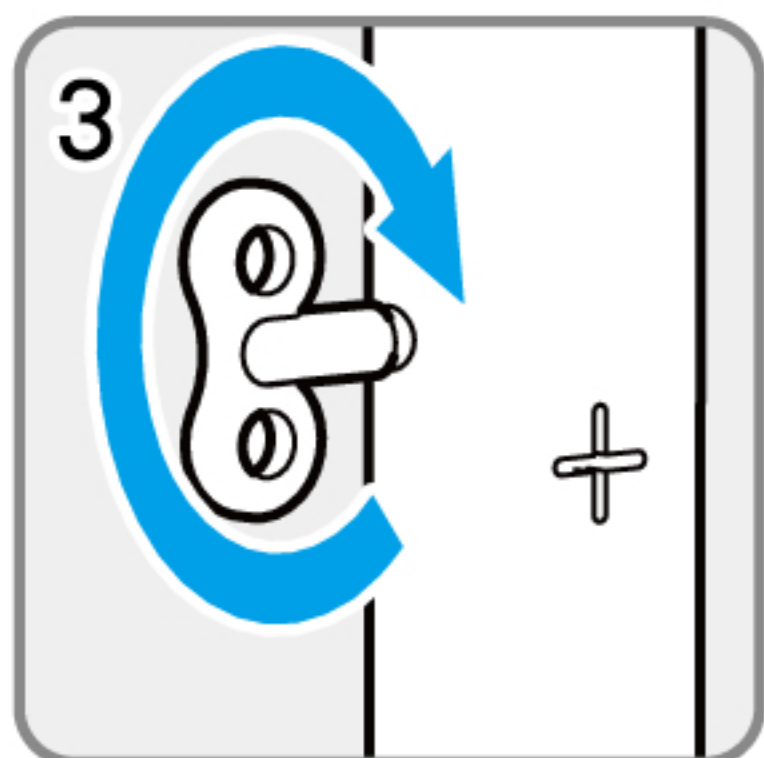

Зафиксируйте ножку

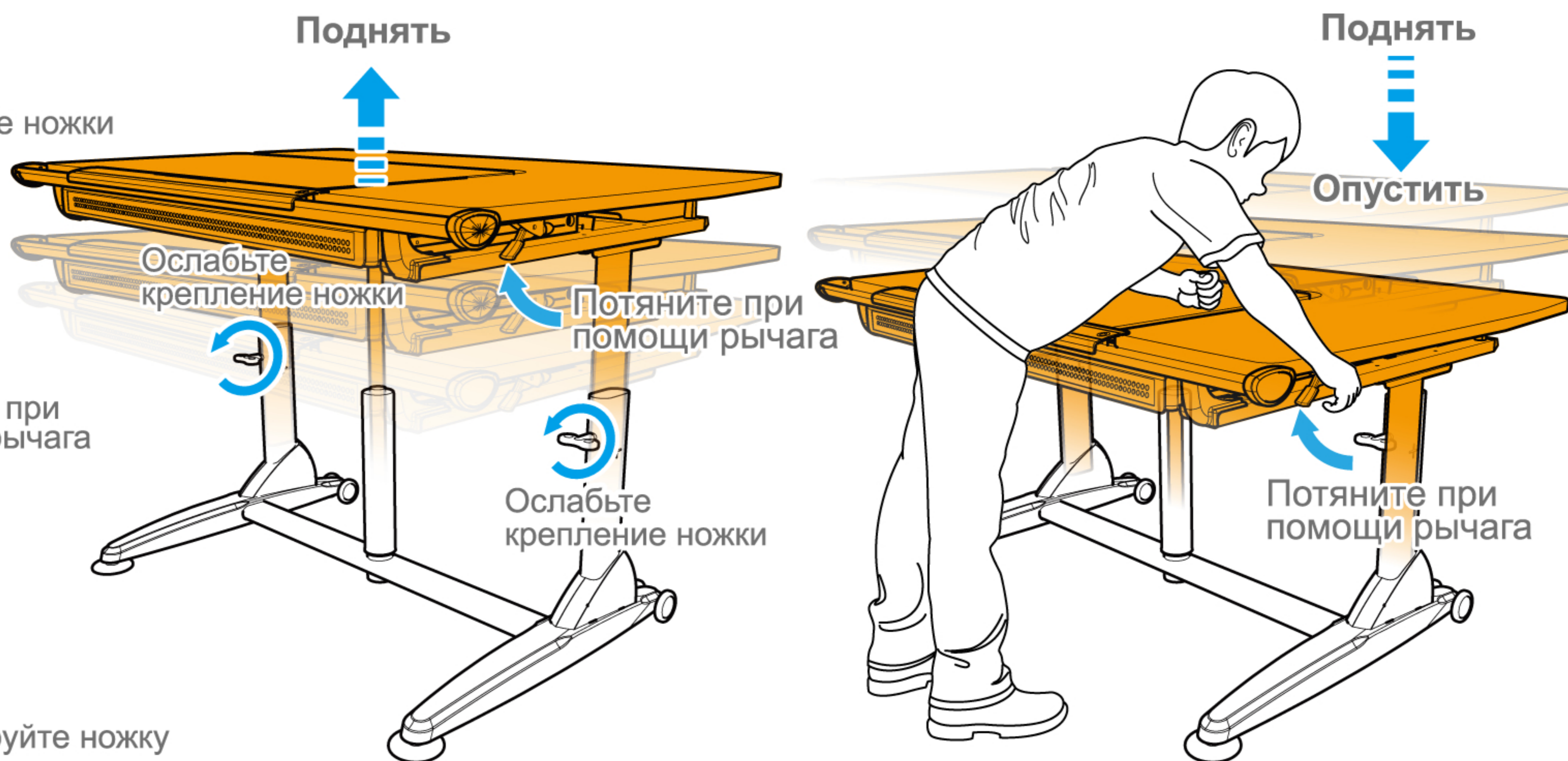

Регулировка наклона

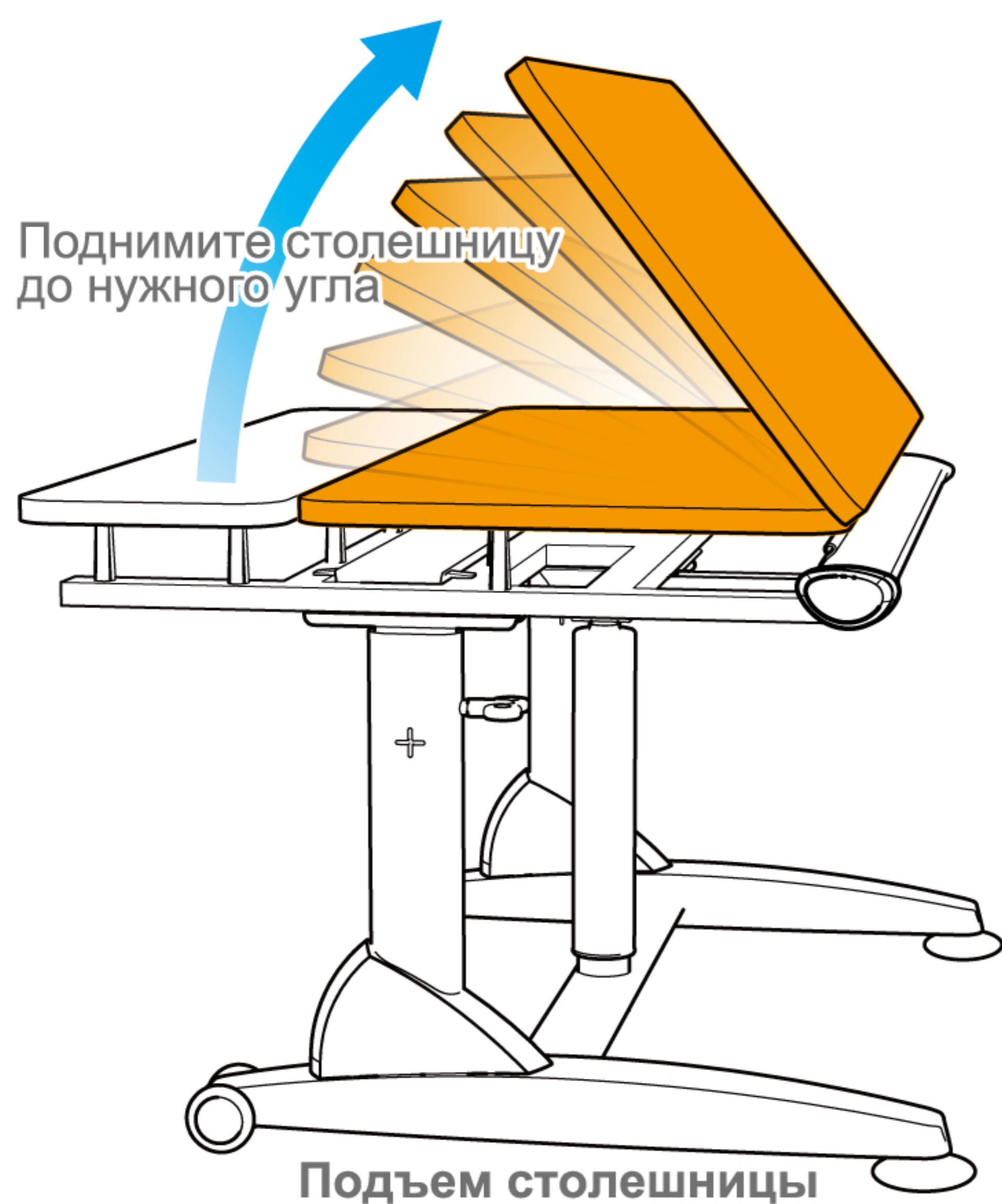

Регулировку осуществлять в сопровождении взрослых



А. Что такое 10+5+1 ?

Все изделия Kid2Youth протестированы и сертифицированы на соответствие международным стандартам, поэтому мы с уверенностью даем гарантию сроком 10 лет, 5 лет или 1 год на разные части изделия.

В. Гарантия и обслуживание

1. Информирование первичных дилеров [Kid2Youth] и [TCT Dynamic Workstation] о дефектах.
2. Ремонт или замена аналогичных или похожих изделий после подтверждения дефекта.
3. Бесплатно. В случае подтверждения дефекта все расходы несет [Kid2Youth] и [TCT Dynamic Workstation].
4. Гарантия действительна только в случае подтверждения со стороны Kid2Youth Corporation.
5. Детали заменяются на новые, при этом право собственности переходит к [Kid2Youth] и [TCT Dynamic Workstation].
6. В случае снятия с производства деталей, эквивалентных дефектным, изделия заменяются аналогами.
7. Работы по обслуживанию проводятся исключительно дилерами и дистрибьюторами, уполномоченными Тайваньским подразделением [Kid2Youth] и [TCT Dynamic Workstation].

С. Гарантийные сроки

10-летняя гарантия: газ-лифт STABILUS производства Германии. (см. подробную информацию в пункте D)

5-летняя гарантия: основные и вспомогательные конструкции. (столешница, основная конструкция кресла, шкаф, аппаратура. (см. подробную информацию в пункте D)

1-летняя гарантия: все расходные материалы. (полиуретановые колесики, регулируемые ножки. См. подробную информацию в пункте D).

Д. Исключения из гарантии

1. Гарантия не распространяется на ущерб, причиненный человеком, стихийные бедствия, климатические условия (влажность) и неправильную эксплуатацию.
2. Гарантия не распространяется на ущерб, причиненный неправильным демонтажом и ремонтными работами, осуществляемыми своими силами.
3. Гарантия не распространяется на разницу в цвете, естественное выцветание.
4. Гарантия не распространяется на покупку образцов, выставочных образцов и изделия в разрезе.
5. Гарантия не распространяется на изделия, бывшие в употреблении.
6. Гарантия не распространяется на изделия без гарантийного полиса, выданного дилером, дистрибьютором или представителем компаний [Kid2Youth] и [TCT Dynamic Workstation].
7. Компании [Kid2Youth] и [TCT Dynamic Workstation] сохраняют за собой право на внесение изменений в любой момент.

Е. Руководство по техническому обслуживанию

1. Тщательно изучите инструкцию по сборке и руководство по эксплуатации.
2. Произвольный демонтаж запрещен. При необходимости он осуществляется квалифицированными работниками.
3. Настоятельно рекомендуется проводить регулярные осмотры и смазку.
4. Периодически регулируйте высоту для профилактики плавной работы системы газ-лифта.
5. Периодически проверяйте степень затяжки винтов.
6. Запрещается использовать разъедающие моющие средства и грубую ткань. Поддерживайте изделия в сухом виде.

Диагностика и устранение неисправностей

Есть проблемы с подъемом и опусканием столешницы?

- Посмотрите, нет ли на столешнице предметов, перевешивающих ее на одну сторону.
- Убедитесь в том, что парта ровно выставлена на горизонтальной поверхности.
- Если вышеуказанные причины не подходят, и проблема остается, ослабьте все винты и протяните их по одному по диагонали.

Если проблема остается после того, как вы перепробовали все вышеописанные меры, свяжитесь с дилером или дистрибьютором.

Не работает механизм регулировки угла наклона?

- Зафиксируйте положение, в котором застряла столешница.
- Обработайте механизм смазкой для исключения трения, если таковое имеется.

Есть проблемы с подъемом и опусканием столешницы по истечении некоторого времени?

- Посмотрите, нет ли на столешнице предметов, перевешивающих ее на одну сторону. Уберите такие предметы или переместите их в центр!
- Уберите вещи с парты. Потяните за тросовый регулятор для подъема столешницы. Повторите операцию несколько раз.

